

Owner's Manual



Call us for information:
1-888-484-9376 (US)
(toll free in the United States)
450 589-8100 (Canada)



30053005-0-00000-0
P_OPMAN_v5.06_EN

© 2024 by Hydro Mobile, a division of BrandSafeway Access, Inc. All rights reserved
 This manual was produced by Hydro Mobile, a division of BrandSafeway Access, Inc., on Adobe® InDesign CC® for Windows®.
 Technical drawings were prepared using Autodesk Inventor®. Illustrations were created with Autodesk Inventor®, Adobe® Illustrator CC® for Windows® and Adobe® Photoshop CC® for Windows®.
 This manual may not, in whole or in part, be copied, photocopied, reproduced, translated, or converted to any electronic or machine readable form without prior written consent of Hydro Mobile

NOTE

All assembly and operation instructions located on the motorized unit and the bridges take precedence over information contained in this manual. Should there be any discrepancies discovered throughout any published documentation issued by Hydro Mobile or its authorized affiliates, the following order of precedence shall prevail:







1. **Written documents issued by the Hydro Mobile Engineering department**
2. **Recall instructions**
3. **Assembly or operation instructions displayed on the motorized unit**
4. **Owner's manual**

Any use of one or several Hydro Mobile motorized units, with or without accessories, in such a configuration or manner as not explicitly described in this manual is prohibited without the prior written permission of Hydro Mobile.

REVISION LIST	
Date / version	Description
Apr 2003 v 1.0	First edition of Owner's manual
Oct 2004 v 2.0	Overall revision 2004
Feb 2005 v 3.0	Addition of bearing bridge; changes to load capacities
Sept 2005 v 3.1	Overall revision; APAVE certification 2005; inclusion of information on 7' (2,1 m)/min model
Dec 2005 v 3.2	Changes to electric diagram for 7' (2,1 m)/min model
Jan 2008 v 4.0	Overall 2007-2008 revision; inclusion of additional accessories; addition of load capacity charts for front/rear extension bridges
Apr 2015 v 4.1	Last edition of version 4; inclusion of additional accessories and corresponding load capacities; this version applies to units with serial number PU-0831 and previous
Feb 2015 v 5.0	Major changes to motorized unit and main components; unit now identified as 7' (2,1 m) per min; this version applies to units with serial number PU-0832 and up
Sep 2015 v 5.01	Minor corrections
Feb 2016 v 5.02	Changes to definitions of competent person and qualified persons
Oct 2016 v 5.03	Minor corrections; changes to values in <i>Minimum Bearing Surface Capacities</i> table; standardization of installation and dismantling procedures; inclusion of mast handler
Mar 2024 v 5.04	Changes to credits page and introduction page
Jul 2024 v5.05 30053005-0-00000-0	Additional information about wind speeds; introduction of 27" guardrails and gap filler; inclusion of location and list of stickers; inclusion of storage instructions for motorized unit, guardrails, mast sections, etc.; inclusion of instructions for opening and closing rear extension; inclusion of all motorized unit stickers and their location
Aug 2024 v5.06 30053005-0-00000-0	Modification to methods of installation table and tie level installation schedules.

LEGEND OF ICONS

These icons are used to highlight important information throughout this manual

	Danger Immediate hazard: if not avoided, will result in serious injury, even death		Notice	Useful information to avoid equipment damage
	Warning Hazardous situation: if not avoided, could result in serious injury, even death and equipment damage		Information	Useful information for safe and easy operation
	Caution Potentially hazardous situation: if not avoided, may result in minor or moderate injury and equipment damage		Useful tip	A useful tip to facilitate installation or operation

The information and instructions contained in this manual applies to units bearing the following serial numbers

PU-0832 and up

GENERAL INFORMATION	
Motorized unit serial number	
Manufacturing date	

HYDRO MOBILE
 www.hydro-mobile.com
 125 de L'Industrie
 L'Assomption, Quebec,
 Canada
 J5W 2T9

For orders or information:
 1-888-484-9376 (US)
 (toll free in the United States)
 450 589-8100 (Canada)
 30053005-0-00000-0

General Information

Introduction 5
 Warranty 6

Performance and Safety

Performance and safety rules 7
 Definition of the competent person 7
 Definition of the qualified person 7
 General guidelines 7

1 – Motorized Unit

Overview 10
 List of components included with shipped unit 11
 Specifications 12
 Weight of components 14
 Dimensions 15
 Bearing surface and cribbing requirements
 Minimum bearing surface capacities 16
 Recommended cribbing 17
 Rear extension platform on the motorized unit
 Opening the rear extension platform 17
 Closing the rear extension platform 17
 Installation of a setup
 General guidelines 18
 Selection of the appropriate configuration 18
 Definition of a standard configuration 18
 Equipment and accessories allowed for
 non-standard configurations 19
 Preparation of the area for the installation 19
 Mandatory instructions for initial installation 20
 Methods of installation
 Freestanding setups
 Standard single unit configuration 21
 Standard twin units configuration 23
 Tied setups
 Progressive installation
 Standard single unit configuration 25
 Standard twin units configuration with mast ties 27
 Pre-installation of tie levels
 Non standard single unit configuration 30
 Non standard twin units configuration 32
 Dismantling an installation
 Safety guidelines 36
 Freestanding setups
 Standard single unit configuration 37
 Standard twin units configuration 38
 Tied setups
 Standard single unit configuration 39
 Standard twin units configuration 40
 Non standard single unit configuration 41
 Non standard twin units configuration 43

2 – Safety Devices

Inclinometer 45
 Safety hooks system 47
 Fall protection 48
 Emergency descent control device 49

3 – Bridges

Bridge types 50
 Standard bridge
 Installation of a 5' (1.5 m) bridge on the motorized unit 51
 Assembly of two 5' (1.5 m) or 30" (76 cm) bridges 51
 Installation of a multi-purpose bridge on the motorized unit 51
 Assembly of two multi-purpose bridges 51
 Cantilever bridge
 Installation 52
 Bearing bridge
 Safety guidelines 52
 Assembly of a bearing bridge structure 52
 Installation of a bearing bridge structure 53
 Dismantling a bearing bridge structure 54
 Front/Rear extension bridge 54
 Bridge deck extension 55
 Swivel bridge
 Installation 56
 Angle adjustment 56
 Installation of swivel bridge guardrails
 on front cantilever configurations 57

4 – Power Pack and Operating Components

Startup preparation instructions 58
 Engine and motorized unit startup procedure 58
 Raising the platform 59
 Lowering the platform 61

5 – Mast and Mast Ties

Mast sections
 Installation of a single mast section 63
 Removing a single mast section 63
 Transport and storage of mast sections 64
 Mast ties
 General guidelines 64
 Installation of a mast tie attachment assembly 64
 Installation of standard mast ties 65
 Mast tie requirements for planking configurations 65
 Methods of installation 66
 Tie level installation schedule 66
 Passing tie levels 67
 Removing mast ties 67

5 – Mast and Mast Ties (cont'd)

Wind speed warning 67
 Correction of the twist in a mast 68
 Angled mast ties
 Installation of the angle bracket 69
 Assembly of an extended mast tie 69
 Installation of extended mast ties 69
 Anchoring system
 Wall tie reactions 71
 Wall tie types 71
 Installation guidelines for horizontal anchoring 72
 Installation guidelines for fixed wall ties 72
 Installation guidelines for a welded wall tie on a beam 72

6 – Load Capacities

General guidelines 73
 Calculating the maximum number of workers
 allowed on a given installation 73
 Evenly distributed
 Single unit setup 75
 Twin units setup 76
 Rear/Front extension
 Bearing bridge setup
 with rear/front extension 77
 Cantilever bridge setup
 Rear/front extension with 30" (76 cm) bridge
 or a multi-purpose bridge 78
 Rear/front extension with a 5' (1.5 m) bridge 79
 Swivel bridge installation
 Single unit (front 90 degrees) 80
 Single unit (front 0-45 degrees) 80
 Hoist installation
 Single unit configuration 81
 Twin units configuration 82

7 – Accessories

Guardrails
 Installation of a guardrail adapter bracket 83
 Installation of 27" (69 cm) guardrails 84
 Adjustment of gap fillers on 27" (69 cm) guardrails 84
 Installation of a 60" (152 cm) guardrail 84
 Installation of a 30" (76 cm) guardrail 85
 Installation of a 33" (81 cm) guardrail 85
 Plank-end guardrails 85
 Face guardrail supports 86
 Universal plank safety support 86
 Movable guardrail 86
 Retractable rest platform 87
 Access bridge 88
 Access stairs 89
 Bridge installation support brackets 89
 Outriggers
 Planking configuration guidelines 90
 Non standard planking configurations allowed 91
 Cross boxes 91
 Auxiliary electric power pack bridge
 General guidelines 92
 Specifications 93
 Installation of the auxiliary power pack bridge 94
 Installation and connection of the power cable 95
 Startup procedure 95
 Shutdown procedure 95
 Removing the power pack bridge 95
 Restoring connections on the motorized unit 95
 Freestanding base 96
 Adapter base for sidewalk canopy installation 99
 Tie level installation schedule 100
 Mast base plate 101
 Tie level installation schedule 102
 Minimum bearing surface capacities 102
 Multiple mast handler 103
 Caster wheels 104
 Hoist support assembly 105
 Weather protection for bridges 106
 Monorail 107

8 – Transport, Storage and Maintenance

Transport and storage
 Preparation of the motorized unit for
 transport 108
 Storage of the motorized unit guardrails 108
 Storage of a standard guardrail 109
 Storage of a bridge 109
 Storage of a mast section 109
 Storage of the control post 109
 Storage of the access stairs 110
 Storage of the access bridge 110
 Storage of the motorized unit 110
 Lifting and moving a motorized unit setup 110
 Inspections and maintenance
 Daily and weekly inspections and maintenance
 Inspection and maintenance of the cylinder hook 112
 Greasing of the mast carriage guide rollers 113
 Greasing of the base outriggers 113
 Inspecting and greasing the safety hooks 114
 Frequent inspections and maintenance 114
 Annual inspections and maintenance 115
 Stickers 116
 Hydraulic diagram 120
 Electric diagram 121

Introduction

Dear owner or user:

Thank you for investing in a Hydro Mobile P Series mast climbing work platform system. The design of this motorized unit reflects over two decades of continued field operation, testing and research work and comes as a solution to our company's deepest concern, your safety and well-being on the job.

To ensure that the workplace becomes safer and more efficient using a Hydro Mobile system, always have appropriately trained personnel assemble, operate, dismantle and move your mast climbing work platform system. These qualified persons will be required to read this owner's manual and assimilate the information contained herein. Failure to do so could lead to serious injury and/or equipment damage.

This motorized unit was designed in accordance with the following standards: US ANSI A92.9-2011, CAN/CSA B354.9-17, ISO 16369:2007 and EN 1495. Furthermore, this motorized unit and the owner's manual comply with US ANSI A92.9-2011 standards, Federal Occupational Safety and Health Administration Standards OSHA 29CFR1926 subpart L; with ISO 16369:2007, CAN/CSA B354.10-17 and CAN/CSA B354.11-17; and with EN 1495.

To ensure safety, maximize the life expectancy of your equipment and to enjoy years of dependable and secure operation, this Hydro Mobile system must be serviced according to maintenance schedules and recommendations provided in this manual. It is also advised to refer to the engine or motor user's manual included with the motorized unit.

Should you have any questions or concerns, please contact the nearest authorized service center or Hydro Mobile directly at 888-484-9376 (in the United States) or at 450 589-8100 (in Canada). You can also visit our website at www.hydro-mobile.com for additional support and information on our factory safety and performance training seminars.

We wish you years and years of safe, productive construction and renovation work.



WARNING

To ensure that the workplace becomes safer and more efficient using a Hydro Mobile system, always have appropriately trained personnel assemble, operate, dismantle, transfer and maintain your work platform system. These qualified persons will be required to read this owner's manual and assimilate the information contained herein. Failure to do so could lead to serious injury and/or equipment damage.

Hydro Mobile Warranty Policy

Warranty period

Hydro Mobile, a division of BrandSafway Access, Inc., herein referred to as Hydro Mobile, warrants its new P Series motorized units to be free from defect of materials and workmanship for a period of 15 months from the date of delivery to the authorized distributor/service center.

Hydro Mobile also warrants its new P Series parts and accessories to be free from defect of materials and workmanship for a period of 15 months from the date of delivery to the authorized distributor/service center.

Product registration

In accordance with standards governing most climbing work platform systems, the owner of a Hydro Mobile P Series unit **must register the product with Hydro Mobile within sixty (60) days**. The initial buyer of a Hydro Mobile P Series unit is automatically registered by Hydro Mobile.

Hydro Mobile must be kept informed of any change of ownership. The new owner must provide Hydro Mobile with a full name and address, along with the model and serial number of the unit acquired.

Description of warranty

Parts and accessories manufactured by Hydro Mobile

Hydro Mobile's obligation and liability under this warranty are expressly limited to repairing or replacing with re-manufactured or new parts, at Hydro Mobile's option, any part and accessory manufactured by Hydro Mobile proven defective after inspection by Hydro Mobile which appear to have been defective in material or workmanship. Only permanent repairs will be covered under this warranty. Hydro Mobile reserves the right to ask for maintenance records of the defective part before settling a claim and to deny such claim if maintenance records are not available or not compliant with maintenance schedules.

This warranty shall not apply to component parts or accessories of products not manufactured by Hydro Mobile and which carry the warranty of the manufacturer thereof or to normal maintenance (such as engine tune-up) or any part necessary to perform such maintenance. Hydro Mobile offers no other warranty, expressed or implied, and offers no warranty of merchantability or fitness for any particular purpose.

Engine

All engines manufactured by Honda under the "GX" lineup are covered by an international warranty of 36 months (12 months on mufflers) and 36 months for Toshiba electric motors. To have an engine repaired under this warranty, the engine must be brought to an authorized Hydro Mobile distributor/service center or to an authorized Honda or Toshiba service center.

Battery

All the batteries shipped from the factory with new equipment are guaranteed for a period of 60 days. Any battery discharged due to operator error will not be covered under this warranty. Dead batteries that can be recharged will not be replaced under this warranty.

Costs and liability associated with warranty

Hydro Mobile's obligation under such warranty shall not include duty, taxes or any other charge whatsoever, or any liability for direct, indirect, incidental or consequential damage or delay.

Exclusion

Any use of one or several Hydro Mobile motorized units, with or without accessories, in such a configuration or manner as not explicitly described in the owner's manual is prohibited without the prior written permission of Hydro Mobile.

Any improper use, including operation after discovery of defective or worn parts, shall void this warranty. Improper use also includes operation beyond rated capacity, substitution of parts other than those approved by Hydro Mobile, including anchor systems, or any alteration, modification or repair by others in such manner as in Hydro Mobile's judgment affects the product materially and adversely.

Labor

All warranty work must be performed by a certified Hydro Mobile technician to be eligible for reimbursement under the warranty.

Performance and Safety Rules



SAFETY comes first. The installation and operation of a mast climber is subject to hazards that can be avoided only by using extreme care and common sense, and by providing the **appropriate training and supervision** to all its users.

It is essential that the **installation and dismantling** of a P Series motorized unit and its related accessories be carried out according to the guidelines, instructions and warnings included in the owner's manual and performed by **qualified erectors/dismantlers** under the supervision of a **competent person** (see boxes below).

It is also imperative that the **operation** of a P Series motorized unit setup be carried out according to the guidelines, instructions and warnings included in the owner's manual. To ensure safe and proper operation, Hydro Mobile recommends that **two persons** be on hand to perform maneuvers for **each motorized unit in a setup** and that **at least one of those two persons is a qualified operator** (see box below) for a P Series motorized unit and its accessories.



NOTICE

The P Series configurations and the methods to achieve these configurations as shown and described in this owner's manual are the only ones authorized by Hydro Mobile.

Definition of the competent person

Competent person means a person who is capable of identifying existing and predictable hazards in the surroundings or working conditions which are unsanitary, hazardous or dangerous to employees, and who has authorization to take prompt corrective measures to eliminate them.

Definition of the qualified person

"**Qualified**" means a person who, by possession of a recognized degree, certificate or professional standing, or who by extensive knowledge, training and experience, has successfully demonstrated the ability to solve or resolve problems relating to the subject matter, the work or the project.

Only a **qualified person** on the specific make and model of the Hydro Mobile equipment can carry out the following tasks:

User/operator

A **qualified user/operator** is allowed to operate Hydro Mobile units according to the guidelines, instructions, warnings and methods set out in the owner's manuals and Hydro Mobile training courses and after they have been erected, tested and passed for use by a qualified person.

Erector/dismantler

A **qualified erector/dismantler** is allowed to erect, dismantle, test, pass for use and modify the configuration of Hydro Mobile units according to the guidelines, instructions, warnings and methods set out in the owner's manuals and Hydro Mobile training courses.

Technician

A **qualified technician** is allowed to perform maintenance inspections and repairs on Hydro Mobile units according to the guidelines, instructions, warnings and methods set out in the owner's manuals and Hydro Mobile training courses.

Hydro Mobile recommends that Qualified Persons follow the Hydro Mobile University Training Program on the specific task and specific make and model to get proper qualifications. For more information on the Hydro Mobile University Training Program,

visit www.hydro-mobile.com/training

General guidelines

- 1- Never modify the mast climbing work platform system (including the motorized unit) or use substitute parts. This could adversely affect worker safety, unit performance and void the warranty. In addition, this could lead to serious injury or death.
- 2- Never use a gasoline-powered motorized unit in an enclosed space due to carbon monoxide emissions or in a place where explosives are stored. It is recommended to use the optional P Series auxiliary electric power pack if the installation must be used in an enclosed area. Refer to p. 92 of the *Accessories* section for more information about the auxiliary electric power pack bridge.
- 3- Each motorized unit must be equipped with an appropriate fire extinguisher (not supplied). Use the bracket supplied with the motorized unit to hang the fire extinguisher in a readily accessible location (fig. 1.2, p. 10).
- 4- It is recommended not to smoke on the platform.
- 5- Workers exposed to potential hazards must always wear proper personal protection equipment (PPE) such as a helmet, safety boots, a fall arrest harness, etc., as prescribed by local regulations. In all cases where workers are exposed to fall hazards, fall protection is required.
- 6- To ensure work efficiency, maintain an adequate equipment and parts inventory on the job site. Keep equipment in good condition.
- 7- **IMPORTANT:** It is strongly recommended not to use equipment that may generate excessive vibrations or reactions on Hydro Mobile platforms.
- 8- Contact the distributor/service center or Hydro Mobile for service, repair or technical advice. Refer to equipment type and serial number when calling.

Performance and Safety Rules

Layout plan and preparation of the installation site

- 9- Make sure that a job survey - job hazard analysis has been performed. Refer to p. 115 of the *Transport, Storage and Maintenance* section for more information about the job survey – job hazard form.
- 10- Prepare a layout plan showing how the mast climbing work platform system (motorized units, bridges and accessories) will be positioned near structures or walls to be erected. On long walls, install separate mast climber sections to allow for flexibility. Make sure to position the motorized units so as to provide proper anchoring points for masts.
- 11- For each setup and configuration, a job/task-specific installation and dismantling procedure for any Hydro Mobile equipment used must be compiled in consultation with and approved by a qualified person before proceeding with the installation or dismantling of the equipment. The procedure must be part of the *Safe Work Plan* (SWP) and must be reviewed in pre-task planning/tool-box talks.
- 12- Establish the distance between the mast climbing work platform system and the structure or wall, taking into account the length of plank outriggers, as well as curvatures, balconies, columns, trees, telephone wires, electrical lines, etc.
- 13- Refer to and follow local regulations governing distances between the mast climbing work platform system and electrical lines. As a reference, North American regulations generally recommend keeping a minimum safe approach distance (MSAD) of at least 10' (3 m) from overhead power lines carrying 50 000 volts or less.
- 14- Make sure the ground or support surface capacity meets with values included in the *Minimum Bearing Surface Capacities* table on p. 16 of the *Motorized Unit* section. Soil compacting, cribbing or shoring can increase bearing capacity. Contact a licensed engineer for assistance.
- 15- While they can be used to help level the motorized unit, the **jacks on the base outriggers are specifically designed to stabilize the motorized unit and must not be used to support any load**. Make sure the motorized unit is **resting on the main jacks on the base** (4) and that the optional caster wheels, if installed, are no longer in contact with the ground before using the motorized unit. Contact a licensed engineer for assistance.
- 16- **Prior to installation, prepare an emergency evacuation plan that is specific to the job site and is in accordance with local regulations.**
- 17- Make sure that there is a **reliable** and **adequate** alternate power source available (generator, extension cord, etc.) to supply the emergency descent system (120 volts in North America, 240 volts in Europe).
- 18- After installation, mark off limit areas of the system using fencing, barriers, warning tape and note emergency phone numbers (fire and police dept.) for quick reference.
- 19- The **qualified erectors/dismantlers** in charge of the installation must make sure that the equipment being installed has been duly inspected and meets all applicable safety standards.

Non linear configurations

- 20- Any P Series setup requiring an approved, angled or non-linear configuration achieved with a front/rear extension or a swivel bridge **must have mast ties and all tie levels must be completely pre-installed to the top of the installation before the start of any work**.

Additional equipment and accessories

- 21- Any P Series setup requiring the use of additional, approved accessories and equipment such as a hoist structure specifically manufactured to be used on a P Series installation, weather protection, a swivel bridge or an approved planking configuration wider than the standard three planks **must have mast ties and all tie levels must be completely pre-installed to the top of the installation before the start of any work**.

Equipment and accessories not rated for use with P Series motorized units

- 22- The P Series motorized unit **must not be used** with any equipment or any accessories not specifically manufactured and rated by Hydro Mobile to be used with P Series motorized units.

Height of mast and tie levels

- 23- It is **mandatory** to refer to the *Tie Level Installation Schedule* table on p. 66 of the *Mast and Mast Ties* section and to the *Load Capacities* section starting on p. 73 **before the installation** of any P Series mast climbing work platform setup.
- 24- The P Series motorized unit **must not be used on a mast with a height over 250' (76 m)**.
- 25- The use of appropriate fall protection equipment is **mandatory** when installing or removing mast sections and tie levels. Failure to use fall protection equipment can expose the erector/dismantler to serious injury or death.

Guardrails, access doors and panels, fall protection and planking

- 26- In all cases where workers are exposed to fall hazards, installation of all the necessary guardrails is **mandatory**.
- 27- No load must be applied on a guardrail. Material must be stored away from guardrails. It is also forbidden for anyone to lean on a guardrail.
- 28- All access doors and panels on the motorized unit must be closed when they are not in use. All access doors and panels must be free from any material or obstruction.
- 29- In all cases where workers are exposed to fall hazards, fall protection is required. Tie points located on the motorized unit (fig. 2.15, p. 48) are designed to resist to a maximum arrest force of 5000 lb (2268 kg) and can be used by workers to tie themselves to the unit (not more than one worker per tie point).

Performance and Safety Rules

Guardrails, access doors, fall protection and planking (cont'd)

- 30- Planks used for planking must be scaffold graded (SPF), in good condition and meet local regulations.
- 31- The use of appropriate fall protection equipment is mandatory when modifying plank configuration or whenever the worker is exposed to a fall hazard. Failure to use fall protection equipment can expose the user to serious injury or death.

Loading the platform

- 32- The deposit of loads on the platform must be done with extreme care, under proper supervision to ensure the stability of the installation must be ensured at all times. Refer to the *Load Capacities* section on p. 73 for more information about loads allowed on the platform. It is **mandatory** to refer to the wind speed warnings on p. 67 of the *Mast and Mast Ties* section for complete instructions.
- 33- **Never load bridges or motorized units beyond their rated capacities.** Overloading may bring damages to equipment or cause the installation to become unbalanced, leading to serious injury or death.

When the installation is in use

- 34- When the motorized unit is moving, it is **mandatory** that all material be removed from planks and that all workers stand in an area on the platform close to the rear guardrails.
- 35- In the event of an abnormal occurrence or operation which could compromise safety (for example, malfunction of a motorized unit component, collision with an obstacle, etc.), immobilize the motorized unit and inform the **competent person**. For the definition of a competent person, refer to p. 7 of this section.
- 36- **Do NOT** touch any of the moving parts on the work platform system when it is in use.
- 37- The motorized unit must not be used or operated during an electrical thunderstorm. A motorized unit that is exposed to a thunderstorm must be submitted to a daily inspection by a qualified person before operation can be resumed. For the definition of a qualified person, refer to p. 7 of this section.

Accessing the platform

- 38- Each person must access the platform by the access stairs, a staircase, through an opening in the building or, when the unit is at least 10' (3 m) above base level, by the **right-hand side** of the mast, using the access bridge to reach the platform. The use of the access bridge is **mandatory** to reach the platform by the mast. To avoid crushing hazards, it is important to make sure that the access ladder is **fully extended** before it is used. Refer to p. 88 of the *Accessories* section for more information on the installation and use of the access bridge. In all cases, transfer must be safe and free from obstruction.

Climbing up or down the mast

- 39- The use of the access bridge is **mandatory** to reach the platform when climbing up or down the mast.
- 40- The use of appropriate fall protection equipment is **mandatory** when climbing up or down the mast at heights between 30' (9,1 m) and 69' (21 m). Failure to use fall protection equipment can expose the user to serious injury or death.
- 41- It is not recommended to climb up the mast to reach work areas at heights over 69' (21 m) because of the time and effort required to reach such heights. The use of alternate equipment compliant with local regulations, such as a rapid mast climber, a transport platform system, or a conventional scaffold stair system will prove to be more efficient. Refer to local regulations for more information.
- 42- Only one person at a time may evacuate the platform by climbing down the mast. It is not recommended to evacuate the platform by climbing down the mast when the platform is at heights beyond 69' (21 m).

Inspection and maintenance of the equipment and accessories

- 43- Inspection and maintenance operations must be carried out efficiently and in a timely manner. Daily inspections and their related operations must be performed by a **qualified user/operator** every day or before every working shift. Frequent and annual inspections and their related operations must be carried out by a **qualified technician**. Refer to the *Transport, Storage and Maintenance* section on p. 112 for more information on inspection and maintenance requirements for P Series motorized units and their accessories. For the definition of a qualified user/operator or a qualified technician, refer to p. 7 of this section.



WARNING

It is **mandatory** to refer to the *Tie Level Installation Schedule* table on p. 66 of the *Mast and Mast Ties* section **before the installation of any** P Series motorized unit setup.

Motorized Unit

Motorized unit – Overview

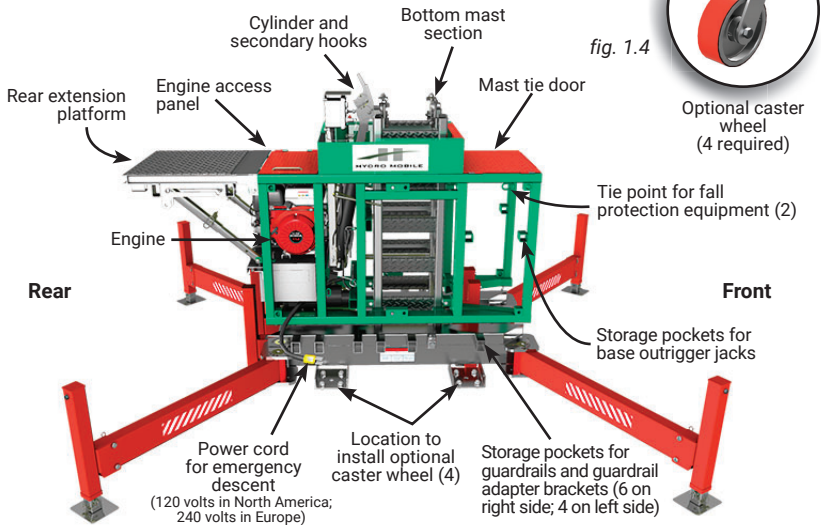
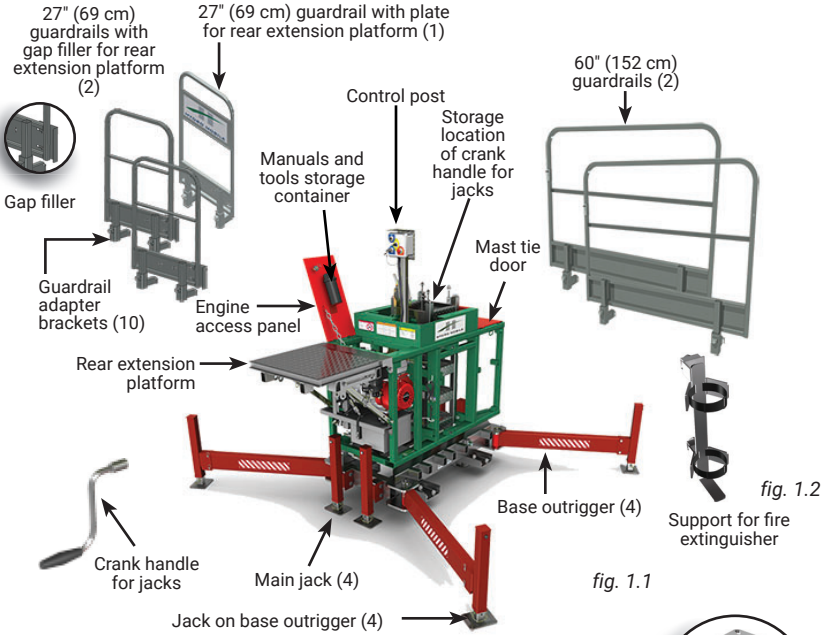

Motorized unit – Side view

Note: Items depicted in illustrations may differ from actual products.

Motorized Unit

Motorized unit – Overview

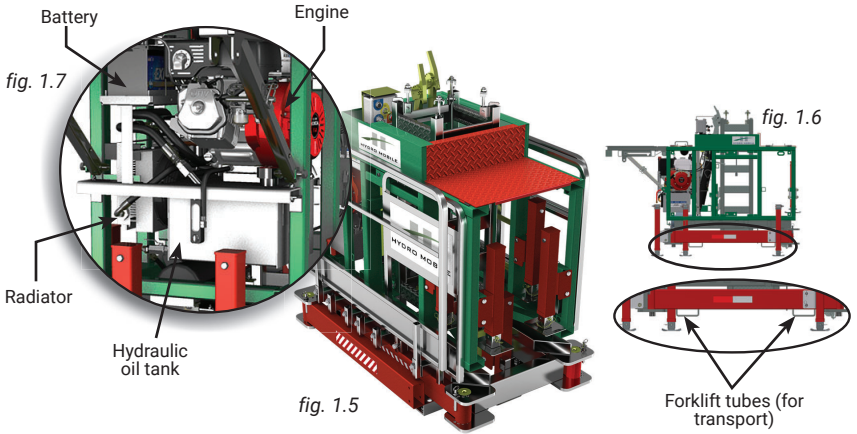

Motorized unit – Rear view

Motorized unit – Typical standard installations

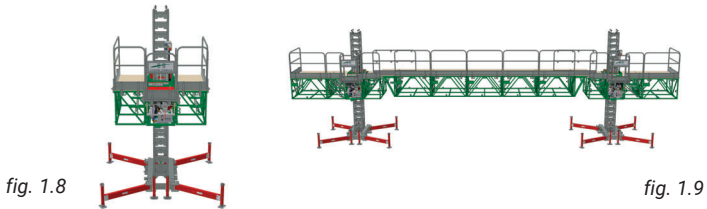

List of components included with shipped unit

Quantity	Component
1	P Series motorized unit ¹
1	Owner's manual
1	15/16" open end wrench
4	Jacks for base outriggers
2	60" (152 cm) guardrails
2	27" (69 cm) guardrails with gap filler
1	27" (69 cm) guardrail with panel
10	Guardrail adapter brackets
2	Bridge installation support brackets
1	Support for fire extinguisher
1	Crank handle for jacks

¹ Refer to fig. 1.1, p. 10, for a view of some of the main components included with the motorized unit.

Notes

The P Series motorized unit is shipped without any outriggers.
The list of components included with each motorized unit shipped may change without notice.

Motorized Unit

Motorized Unit Specifications

fig. 1.11

General Specifications		
Dimensions of the motorized unit (as shipped)	42" x 76" x 76" (W x L x H) (107 cm x 193 cm x 193 cm) (fully assembled)	
Drive system	Hydraulic ratchet drive	
Maximum height	250' (76 m)	
Distance between tie levels	Up to 20' (6,1 m) (refer to the <i>Mast and Mast Ties</i> section for complete information)	
Freestanding height (when freestanding is allowed)	Up to 20' (6,1 m) with base outriggers opened a planking configuration of at least two or a maximum of three planks	
	Up to 35' (10,7 m) with optional freestanding base (when allowed)	
Safety devices	Emergency descent	Independent electrical descent control system
	Safety hooks	Speed-activated hook system
	Inclinometer (included with bearing bridge adapter)	Slope detection switch

fig. 1.12

Specific Features		
Platform weight (as shipped)	Total	2550 lb (1157 kg) (fully assembled)
	Base	1130 lb (513 kg)
	MU structure assembly	1190 lb (544 kg)
Maximum load capacity	Single unit installation	7500 lb at 7'-5" (3402 kg at 2,3 m) 6000 lb at 27'-5" (2722 kg at 8,4 m)
	Twin units installation	11 450 lb at 63'-4" (5194 kg at 19,3 m) 9750 lb at 83'-4" (4423 kg at 25,7 m)
Maximum lifting capacity		8340 lb (3783 kg)
Vertical travel speed		7" (2,1 m) per minute (Honda 9 HP engine)
Mast section		16" x 16" x 60" (41 cm x 41 cm x 152 cm) 235 lb (107 kg) per section
Bridges	30" (76 cm)	31" x 62" x 36" (W x L x H) (79 cm x 157 cm x 91 cm)
	5' (1,5 m)	61" x 62" x 36" (W x L x H) (155 cm x 157 cm x 91 cm)
	10' (3 m)	120" x 62" x 36" (W x L x H) (305 cm x 157 cm x 91 cm)
	Bearing bridge adapter	32" x 62" x 36" (W x L x H) (81 cm x 157 cm x 91 cm)
Guardrails (included)		27" (69 cm) (3) with gap fillers 60" (152 cm) (2)

fig. 1.13

Hydraulic Specifications	
Component	Specifications
Single gear pump	1 x 7,38 GPM (27,9 l/min)
Hydraulic cylinder	1 x 3 1/2" x 23 1/2" x 1 1/2" (8,9 cm x 59,7 cm x 3,8 cm) with 3000 psi counterbalance
Hydraulic tank capacity	6,28 US gal (23,75 l)
Hydraulic oil	Dexron III ATF
Oil filter	Ikron filter model HE K44-20-135-A5-SP010 (HM part number A0410000-0004)

Motorized Unit

Motorized Unit Specifications

fig. 1.14.

Engine Specifications	
Model	Honda GX270
Rated power	9 HP @ 3600 rpm
Fuel consumption in continuous service	2,5 US qt/hour (2,4 l/hour) @ 3600 rpm
Spark plug	BPR6ES
Oil type	SAE 5W30
Gasoline tank capacity	1,71 US gal (6,5 l)
Oil capacity	1,16 US qt (1,1 l)
Electrical power supply	12 VDC - 10 ampere-hour
Battery	12 V - 700 CCA
For any other information regarding the use and the maintenance of Honda engines, refer to the Honda User's manual	

fig. 1.15

Operation Specifications		
Wind exposure		
Situation	Maximum wind speed allowed	
	In service	Out of service
Erection / dismantling	28 mph (45 km/h)	Does not apply
Freestanding setup (when allowed)	28 mph (45 km/h)	Unit must be brought down to base level
Setup equipped with weather protection (when allowed)	28 mph (45 km/h)	Unit must be brought down to base level
Setup with mast ties	35 mph (56 km/h)	94 mph (150 km/h) Loads unloaded from platform and unit between two tie levels
If wind speeds are expected to exceed 94 mph (150 km/h), the motorized unit must be brought down to base level		
Ambient temperature		
Ambient temperature range for operation	-4°F to 104°F (-15°C to 40°C)	
Noise exposure		
Standard noise level (for gas-powered unit)		
(DB-A / 7 m) @ 3600 rpm	79 dBA	

Motorized Unit

Motorized Unit Specifications

fig. 1.16

Weight of Components	
UNIT and components	
Description	Weight
P Series motorized unit (as shipped)	2960 lb (1343 kg)
Base assembly	1130 lb (513 kg)
Structure sub-assembly	1190 lb (540 kg)
Access bridge (assembled)	750 lb (340 kg)
MAST and MAST TIES	
Description	Weight
Mast assembly	235 lb (107 kg)
Mast tie attachment assembly	25 lb (11 kg)
Mast tie assembly	16 lb (7 kg)
Mast tie extension	13 lb (6 kg)
Mast tie short assembly	10 lb (4,5 kg)
Mast tie 30-degree kit	15 lb (6,8 kg)
ACCESSORIES	
Description	Weight
Access stairs assembly	76 lb (34 kg)
Access stairs handrail	21 lb (9,5 kg)
Access stairs extension	23 lb (10 kg)
60" door guardrail assembly	100 lb (45 kg)
Rest platform assembly	31 lb (14 kg)
Multiple mast handler	16 lb (7 kg)
Mast base plate assembly	145 lb (66 kg)
Hoist support structure (including beam, no hoist)	485 lb (220 kg)
Adapter base for freestanding installation	2500 lb (1134 kg)
Adapter base for sidewalk canopy installation	2000 lb (907 kg)
WEATHER PROTECTION and MONORAIL	
Description	Weight
Weather protection X brace (all lengths)	8 lb (4 kg)
Weather protection frame assembly	85 lb (39 kg)
Weather protection frame truss extension assembly	20 lb (9 kg)
Junction plate assembly	20 lb (9 kg)
Monorail beam	85 lb (39 kg)
Trolley for monorail	18 lb (8 kg)
Hoist chain block	31 lb (14 kg)
BRIDGES	
Description	Weight
30" (76 cm) bridge assembly (including guardrail)	250 lb (113 kg)
5' (1,5 m) bridge assembly (including guardrail)	390 lb (177 kg)
10' (3 m) bridge assembly (including guardrail)	710 lb (322 kg)
30" motor bridge 480V assembly	1200 lb (544 kg)
33" (84 cm) multi purpose bridge	310 lb (141 kg)
Bearing bridge adapter (without guardrail)	260 lb (118 kg)
20" (51 cm) bridge assembly (without guardrail)	196 lb (96 kg)
30" (76 cm) deck extension (with outrigger)	57 lb (26 kg)
33" (84 cm) deck extension (with outrigger)	57 lb (26 kg)
60" (152 cm) deck extension (with outrigger)	95 lb (43 kg)
Swivel bridge assembly	800 lb (363 kg)
Swivel bridge counterweight adapter	175 lb (79 kg)
Swivel bridge outrigger adapter	60 lb (27 kg)
GUARDRAILS and OUTRIGGERS	
Description	Weight
27" (69 cm) guardrail with gap filler	43 lb (20 kg)
27" (69 cm) guardrail (with panel)	43 lb (20 kg)
30" (76 cm) guardrail assembly	40 lb (18 kg)
33" (84 cm) guardrail assembly	42 lb (19 kg)
60" (152 cm) guardrail assembly	58 lb (26 kg)
Guardrail adapter bracket	4 lb (2 kg)
Movable guardrail	65 lb (29,5 kg)
Plank-end guardrail	25 lb (11 kg)
Face guardrail bracket	14 lb (6 kg)
32" (81,3 cm) outrigger	8 lb (3,6 kg)
63" (1,6 m) outrigger	18 lb (8 kg)
72" (1,8 m) outrigger	27 lb (12 kg)
84" (2,1 m) outrigger	45 lb (20 kg)
120" (3,04 m) outrigger	55 lb (25 kg)
Cross box assembly	4 lb (1,8 kg)

Motorized Unit

Dimensions of the Motorized Unit

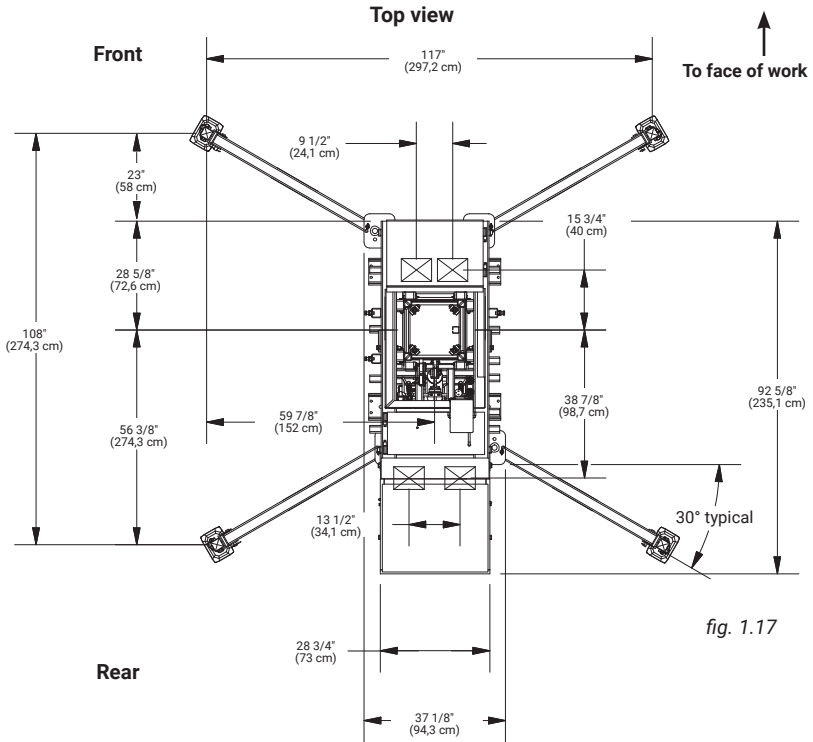

fig. 1.17

* The distance from the face of the work to the motorized unit must be equal to the width of one plank multiplied by the number of planks in the configuration, while allowing 6" to 8" (15 cm to 20 cm) of play. The standard, recommended plank configuration for a P Series installation is two planks.

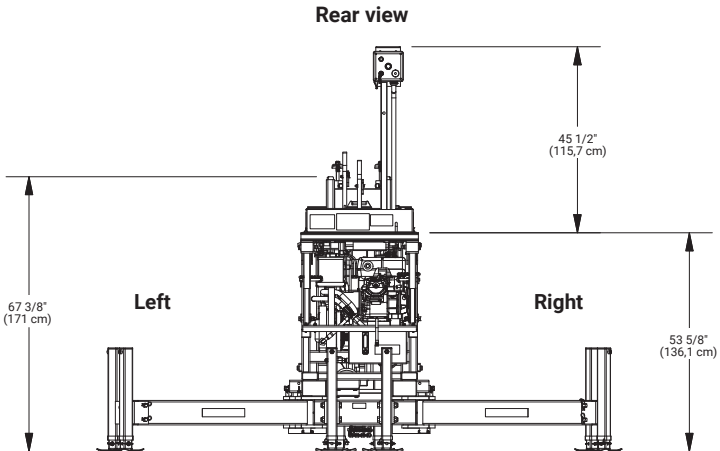

fig. 1.18

Motorized Unit

Bearing Surface and Cribbing Requirements

Bearing surface

Before installing the motorized unit, make sure the bearing surface under it is level, clear of debris and has the proper bearing capacity. When required, appropriate cribbing must be placed under all jacks to distribute the load. It is important to make sure that the bearing surface is stable and has not been subject to any type of erosion or deterioration caused by weather conditions (snow, rain, etc.).

The type of cribbing chosen may vary according to the bearing surface where the setup must be installed.

For example, a setup installed on a concrete slab that is covering the bearing surface may require cribbing consisting of only one plywood panel under the base while a setup installed on a concrete slab that is covering an indoor garage may require shoring in addition to cribbing.

A setup installed on a bearing surface composed of gravel, sand or any such type of surface may require stronger cribbing under the base.

In cases where shoring is required, it is recommended to contact an engineer for assistance.

fig. 1.19

Minimum Bearing Surface Capacities					
Type of installation	Height		Load on each main jack (4)	Load on each outrigger jack (4)	Load under mast
	(ft)	(m)	Reaction *	Reaction	Reaction *
Freestanding installation (single unit or twin units configurations)	20	6,1	4636 lb	2936 lb	13,059 lb
			2103 kg	1332 kg	5923 kg
Installation with mast ties (single unit or twin units configurations)	50	15,2	5203 lb	There must be no load on the outrigger jacks once two tie levels have been installed	14,657 lb
			2360 kg		6648 kg
	75	22,9	5653 lb		15,925 lb
			2564 kg		7223 kg
	100	30,5	6104 lb		17,194 lb
			2769 kg		7799 kg
	200	61,0	7905 lb		22,269 lb
			3586 kg		10,101 kg
	250	76,2	8806 lb		24,807 lb
			3994 kg		11,252 kg

Load reactions under the mast must be considered for an installation using a mast base plate. For more information about the installation and use of a mast base plate, refer to p. 101 of the *Accessories*, section.

* Load reactions in this column include a dynamic factor



WARNING

Make sure the ground or support surface capacity meets with values included in the *Minimum Bearing Surface Capacities* table (fig. 1.19). Soil compacting, cribbing or shoring can increase bearing capacity. Any cribbing product or cribbing method approved by the site engineer can be used to distribute the load on the bearing surface providing it meets the values in the *Minimum Bearing Surface Capacities* table (fig. 1.19). Contact an engineer for assistance.

Motorized Unit

Bearing Surface and Cribbing Requirements

Recommended cribbing for most bearing surfaces

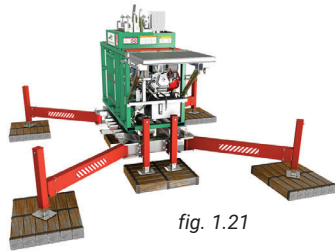
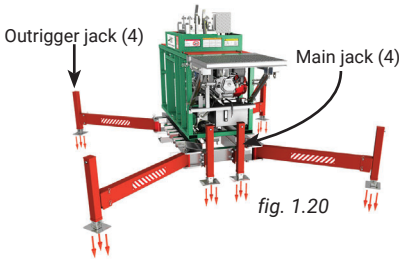

The plywood and lumber used as cribbing must be secured together to prevent slipping.

Recommended Cribbing Pad		
40' x 40' x 6" (102 cm x 102 cm x 15 cm)		
①	Plywood 40' x 40' x 3/4" (102 cm x 102 cm x 2 cm)	2
②	Lumber 2' x 10' x 40" (5 cm x 25 cm x 102 cm)	12

fig. 1.22

Values shown in the table above are for reference only.

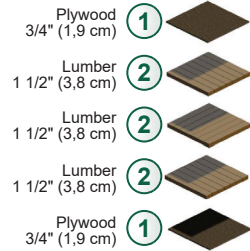

fig. 1.23

Rear Extension Platform on the Motorized Unit

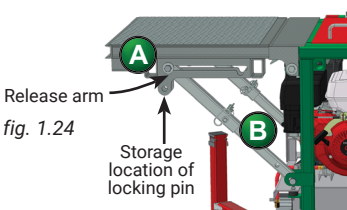

fig. 1.24

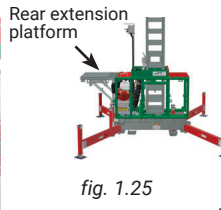

fig. 1.25

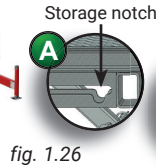

fig. 1.26

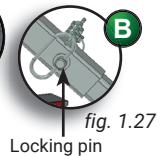

fig. 1.27

Support structure for the rear extension platform

Opening the rear extension platform

- 1- Make sure the motorized unit is at base level. Remove the locking pins (2) on the supports (see "A" in fig. 1.24 and fig. 1.26).
- 2- Lift and support the extension carefully.
- 3- Once the extension is fully deployed, insert a locking pin in each of the supports to secure the extension (see "B" in fig. 1.24 and fig. 1.27).

Closing the rear extension platform

- 1- Make sure the motorized unit is at base level. Slightly lift and support the extension. Remove the locking pins from the supports (see "B" in fig. 1.24 and fig. 1.27).
- 2- Lower the extension carefully until each pivot bolt is in the storage notch (fig. 1.26).
- 3- Store each locking pin in its storage location (fig. 1.27).

Motorized Unit

Installation of a Setup



SAFETY comes first. It is essential that the **installation** of a P Series motorized unit setup be carried out by **qualified erectors/dismantlers** under the supervision of a **competent person** in accordance with all applicable local regulations.

The use of fall protection is **mandatory** for erectors/dismantlers during the installation of mast sections and tie levels. For the definition of a competent person or a qualified erector/dismantler, refer to p. 7. of the *Performance and Safety Rules* section. For information about fall protection, refer to p. 48 of the *Safety Devices* section.

It is mandatory to make sure that the motorized unit installation remains stable and secure throughout the erection maneuvers.

For each setup and configuration, a job/task-specific installation procedure for any Hydro Mobile equipment used must be compiled in consultation with and approved by a qualified person before proceeding with the installation of the equipment.

General guidelines

- 1- Make sure that all loads have been removed from the motorized unit and that all workers have stepped down before lifting and transporting the motorized unit.
- 2- Make sure all the equipment necessary for a safe erection of the installation is on hand (slings, crane or rough terrain forklift, etc., as required).
- 3- It is important to make sure that **all guardrails required for the configuration are available** as some may not be included with bridges and may have to be purchased separately. For more information about guardrails, refer to p. 83 of the *Accessories* section.
- 4- On **freestanding installations**, all base outriggers **must always be opened** at a 30-degree angle (fig. 1.28). Base outriggers **cannot be parallel to the face of the work (at a 0-degree angle) on a freestanding installation** (fig. 1.29).
If necessary, refer to p. 96 of the *Accessories* section for instructions on the installation of an optional freestanding adapter base.

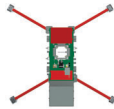

fig. 1.28

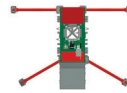

fig. 1.29

- 5- On **tyed installations**, with **base outriggers** opened at a **30-degree angle** (fig. 1.28), the **maximum width** of planking **allowed in front** of the unit is **five planks**. It is important to note that a planking configuration wider than three planks cannot be combined with any other additional accessory or equipment.
On **tyed installations**, when **base outriggers** are required to be **parallel to the face of the work** (at a 0-degree angle) (fig. 1.29) during the initial stages of installation, the **first tie level** must be **installed no higher than 10' (3 m) from base level**. In such a case, the **maximum width** of planking allowed in **front** of the unit is a **one-plank** configuration.
- 6- On **tyed installations**, when **base outriggers** are required to be **closed completely** during the initial stages of installation, it is **mandatory** to refer to and comply with the *Tie Level Installation Schedule* for installations using a mast base plate, on p. 102 of the *Accessories* section.
- 7- It is **mandatory** to refer to the *Tie Level Installation Schedule* table on p. 66 of the *Mast and Mast Ties* section **before the installation** of any P Series motorized unit setup.

Selection of the appropriate configuration

- 8- A P Series installation can be installed in a standard or non-standard configuration. A **standard configuration** is a linear installation (single unit or twin units) that **does not require the use of angled or non-linear equipment**, such as a front/rear extension bridge ("1" in fig. 1.30, p. 19), a swivel bridge ("2" in fig. 1.30, p. 19) or a planking configuration wider than three planks ("3" in fig. 1.30, p. 19), nor of an accessory such as weather protection ("4" in fig. 1.30, p. 19), a monorail ("5" in fig. 1.30, p. 19) or a hoist support structure and a hoist ("6" in fig. 1.30, p. 19).

Non-standard configurations must be installed in standard configuration: any authorized equipment or accessory must be **installed only once all required mast sections and tie levels to reach the total mast height specified in the layout plan are in place.**

Motorized Unit

Installation of a Setup

Selection of the appropriate configuration (cont'd)

Definition of a standard configuration

A **standard configuration**, referred to throughout this owner's manual and related documentation, is a linear installation that **does not require the use of angled or non-linear equipment**, such as a front/rear extension bridge, a swivel bridge, or a planking configuration wider than three planks, **nor the use of an accessory** such as weather protection, a monorail or a hoist support structure with a hoist.

It is **mandatory** to refer to the *Load Capacities* section on p. 73 for the number of bridges allowed in a standard single unit or twin units installation.

Equipment and accessories allowed for non-standard configurations

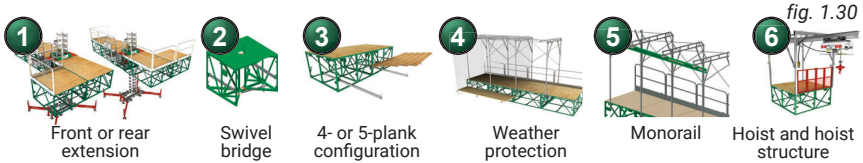

It is important to note that **only one equipment or accessory** required to achieve a non standard configuration is **allowed on a same setup**. Refer to the *Equipment and accessories allowed for NON STANDARD configurations – SINGLE UNIT and TWIN UNITS* table in fig. 1.31 for which equipment or accessory (one per setup allowed only) is allowed for a single unit setup and a twin units setup.



Equipment and accessories allowed for NON STANDARD configurations – SINGLE UNIT and TWIN UNITS	
Configuration	Equipment or accessory allowed (only ONE allowed per setup)
 SINGLE UNIT	1 OR 2 OR 3 OR 4 OR 5 OR 6
 TWIN UNITS	1 OR 2 OR 3 OR 4 OR 5 OR 6
IMPORTANT GUIDELINES for NON STANDARD CONFIGURATIONS: <ul style="list-style-type: none"> • Freestanding is not allowed • It is mandatory to pre-install all required mast sections and tie levels to reach the total mast height specified in the layout plan before installing any equipment or accessory and before starting any work 	

fig. 1.31



NOTICE

In a non standard configuration, it is **mandatory** to **pre-install all required mast sections and tie levels** to reach the total height of the mast as specified in the layout plan **before starting any work**.

Preparing the area for the installation

- 9- In reference to the job survey/job hazard analysis, the layout plan, the selected configuration and the job/task-specific installation procedure, determine if there are obstacles or hazards, what are the cribbing and tie requirements, and make sure that all the components required are available.
- 10- Before installing the motorized unit, determine where the cribbing and the jacks will rest. The bearing surface under the cribbing must be level, clear of debris and have the proper bearing capacity (see the *Minimum Bearing Surface Capacities* table, on p. 16). If a freestanding adapter base is used, the weight of the adapter base (2500 lb or 1134 kg) must be considered in the loads applied on the bearing surface. Should the actual bearing capacity be inferior to the values in the table, seek instructions and recommendations from the site engineer. It is important to note that the **jacks on the base outriggers** are designed to stabilize the motorized unit and plumb the mast, and **must not be used to support the load nor the motorized unit**.

Motorized Unit

Installation of a Setup

Preparing the area for the installation (cont'd)

- Distance from the finished wall must be at least 6" to 8" (15 to 20 cm). Add an additional 2" (5 cm) if using a toe board. Refer to the *Methods of Installation* table on p. 21 for specific instructions about the number of planks allowed in a configuration. Refer also to applicable local regulations to determine play or the maximum allowable distance between the motorized unit, including its accessories, and the face of the work.
- Mark the position of jacks while taking center-to-center distances into account. Base level differences can be compensated for by adjusting the height of the main jacks, or by building wood cribbing.

Mandatory instructions for initial installation

- Lay down the cribbing and make sure it is level on both its front and side axis.
- Unload the motorized unit with a rough terrain forklift or a crane. For more information on the lift and transport of a motorized unit, refer to p. 110 of the *Transport, Storage and Maintenance* section. Before lowering the unit, open all base outriggers. Lock them in place by pushing pins through the holes on the base.
- Using a rough terrain forklift, a crane or optional caster wheels (4), position and align the motorized unit with the face of the work or the structure.
- If the unit is equipped with optional caster wheels, lift the motorized unit using the main jacks (on the base, fig. 1.32) until the wheels no longer touch the bearing surface. Make sure the main jacks are lowered completely to the ground and positioned to support the installation.

fig. 1.34

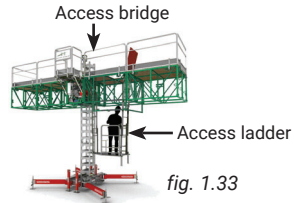
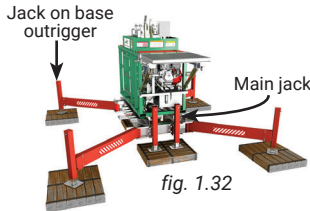

- Verify that the mast is plumb on both its front and side axis. Lift and level the motorized unit using the jacks on the base outriggers. It is important to note that the jacks on the base outriggers are only designed to level and stabilize the motorized unit when installing or removing tie levels, or in a freestanding installation. Jacks on base outriggers must not be used to support the load nor the motorized unit.
- To access the work platform by climbing up the mast, it is mandatory to use an optional access bridge installed on the **right-hand side of the mast**. To avoid any crushing hazard, the access ladder must only be used when **fully extended**. Refer to p. 88 of the *Accessories* section for more information on the installation and use of the access bridge.
- It is also suggested to install an optional retractable rest platform when the setup has been raised at more than 30' (9 m) above base level or beyond the maximum allowable height prescribed by local regulations for mast climbing without a rest platform. Refer to p. 87 of the *Accessories* section for more information on the installation and use of a retractable rest platform.
- It must be noted that a **bridge attached directly on the motorized unit** (to the left or right) must be bolted using **eight bolt assemblies**, while only **six bolt assemblies** are required **when bolting two bridges together**.
- Proceed to the following instruction steps for the installation of the setup, as the configuration requires.



CAUTION

To avoid equipment damage that could affect worker safety and could lead to serious injury, it is important to select and follow the tie level installation schedule appropriate for the configuration. It is mandatory to refer to the *Tie Level Installation Schedule* table on p. 66 of the *Mast and Mast Ties* section before the installation of any P Series configuration. It is also mandatory to refer to the *Load Capacities* section on p. 73 for more information about the loads allowed in a configuration. It is also recommended to review and follow the instructions included in this manual for the installation and use of the accessory or equipment to be installed.

Motorized Unit

Methods of Installation

fig. 1.35

Methods of Installation						
Type of installation	Freestanding (standard configuration only)		With mast ties (standard configuration only)		With mast ties (non standard configuration)	
	(A) Single unit	(B) Twin units (use of freestanding base adapter not allowed)	(C) Single unit	(D) Twin units	(E) Single unit	(F) Twin units
Type of configuration	Standard	Standard	Standard	Standard	Non standard	Non standard
Method of installation of tie levels allowed	No tie levels	No tie levels	Progressive	Progressive	Pre-installation mandatory	Pre-installation mandatory
Width of planking allowed	2 to 3 planks	2 to 3 planks	0 to 3 planks	0 to 3 planks	0 to 5 planks	0 to 5 planks
	NOTE: Methods A, B, C and D can only be used to install standard configurations				NOTE: Methods E and F can be used to install standard configurations as well	

N**NOTICE**

Non-standard configurations must be installed in standard configuration: any authorized equipment or accessory must be installed **only once all required mast sections and tie levels are in place.**

Standard single unit configuration – freestanding**A**

The following installation steps can **only** be used for a **standard configuration**. For the definition of a standard configuration, refer to p. 19 of this section.

Positioning the motorized unit

- 1- Prepare the motorized unit and the area where the setup will be installed.
- 2- Position and install the motorized unit as described in steps 1 through 21 of the general guidelines, starting on p. 18 of this section. If necessary, refer to p. 96 of the *Accessories* section for instructions on the installation of an optional freestanding base. The weight of the adapter base (2500 lb or 1134 kg) must be considered in the loads applied on the support surface. Refer to the *Minimum Bearing Surface Capacities* table, on p. 16, for guidance.
- 3- Make sure the inclinometer bypass is connected. For more information about inclinometers, refer to p. 45 of the *Safety Devices* section.
- 4- Make sure the rear extension platform is lifted and secured. For instructions on how to lift and secure the rear extension platform, refer to p. 17 of this section.
- 5- Make sure that **all base outriggers are opened at a 30-degree angle** (fig. 1.36).

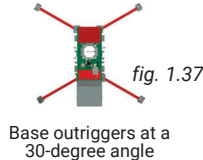
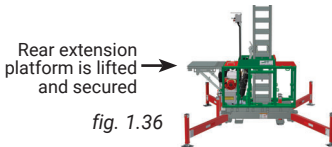

Motorized Unit

Methods of Installation

(A)

Standard single unit configuration – freestanding

Installation of bridges

- 6- Using bridge installation support brackets or any other lifting device such as a crane or a rough terrain forklift, install as many bridges as is required and allowed. Make sure to install bridges alternately on one side of the mast, then on the other, to ensure stability.

It must be noted that a **bridge attached to the motorized unit** (to the left or right) must be bolted using **eight** bolt assemblies, while only **six** bolt assemblies are required when **bolting two bridges together**.

For instructions on the installation of a bridge, refer to p. 51 of the *Bridges* section. For information on the use of bridge installation support brackets, refer to p. 89 of the *Accessories* section. Refer to the *Load Capacities* section on p. 73 for the maximum number of bridges allowed in a setup.

Installation of outriggers and planking

- 7- Adjust the outriggers and install planks, as required and allowed (see p. 90 of the *Accessories* section for more information).

Installation of guardrails

- 8- Before starting to install mast sections, make sure all the required guardrails are in place and secure. In all cases where workers are exposed to fall hazards greater than specified by local regulations, the installation of guardrails or face guardrail supports is **mandatory**. Guardrails must remain in place and secure throughout erecting operations. For more information about the installation of guardrails and face guardrail supports, refer to p. 83 of the *Accessories* section.

Installation of mast sections

- 9- Using a crane or a rough terrain forklift, load mast sections on the platform. **Mast sections loaded on the platform must be stored horizontally and distributed equally on either side of the mast to ensure good balance.** Refer to the *Load Capacities* section on p. 73 for more information about loading the platform.
- 10- Install as many mast sections as required to reach the desired height, equal or inferior to the maximum allowable height for a freestanding installation, making sure throughout the process that the mast remains plumb on both its front and side axis. For instructions on the installation of a mast section, refer to p. 63 of the *Mast and Mast Ties* section. Refer to p. 66 of the *Mast and Mast Ties* section for more details on the maximum allowable height for a freestanding installation.

N

NOTICE

A freestanding standard single unit setup must not be raised over 20' (6,1 m) unless an optional freestanding base is used in the configuration. The weight of the freestanding base (2500 lb or 1134 kg) must be considered in the loads applied on the support surface.

- 11- It is important to make sure to verify the mast bolts when lowering the platform to make sure they are in good condition and are tightened properly, especially on **brand-new mast sections**, as the galvanized coating may have compressed. In all cases, mast bolts must be tightened with a torque of 120 lb-ft (163 N-m). Overtightening or undertightening mast bolts may lead to equipment damage.

Verification of the setup

- 12- Before passing the installation for use and authorizing workers to use the work platform, make a final verification of the setup and perform every step in the daily inspection checklist. If required, fill out the handover sheet to complete the installation. Refer to p. 112 of the *Transport, Storage and Maintenance* section for more information about the daily inspection checklist and to p. 115 for information about the handover sheet.



WARNING

It is important to make sure to verify the mast bolts when lowering the platform to make sure they are in good condition and are tightened properly, especially on **brand-new mast sections**, as the galvanized coating may have compressed. In all cases, mast bolts must be tightened with a torque of 120 lb-ft (163 N-m). Overtightening or undertightening mast bolts may lead to equipment damage.

Adding mast sections progressively

- 13- Repeat steps 9 through 11 when it is necessary to install additional mast sections. If required, modify the handover sheet accordingly.

Motorized Unit

Methods of Installation

Standard twin units configuration – freestanding (requires the use of two bearing bridge adapters – sold separately)

B

The following installation steps can **only** be used for a **standard configuration**. For the definition of a standard configuration, refer to p. 19 of this section. It is important to note that the use of **optional freestanding bases** is **not allowed** for **freestanding twin units installations**.

Positioning the first motorized unit

- 1- Prepare the first motorized unit and the area where the setup will be installed. If the twin units setup will be equipped with an access bridge, it is important to make sure that this access bridge is installed on the motorized unit located the furthest on the right side of the installation (fig. 1.38).
- 2- Position and install the first motorized unit as described in steps 1 through 21 of the general guidelines, starting on p. 18 of this section.
- 3- Make sure the rear extension platform is lifted and secured. For instructions on how to lift and secure the rear extension platform, refer to p. 17 of this section.
- 4- Make sure that **all base outriggers are opened at a 30-degree angle** (fig. 1.41).
- 5- Make sure that a standard 30" (76 cm) bridge is installed as a cantilever bridge on the end of the unit where the bearing bridge structure will be installed. The upper corner of the diagonal brace on the cantilever bridge must point outwards, as shown in fig. 1.39.

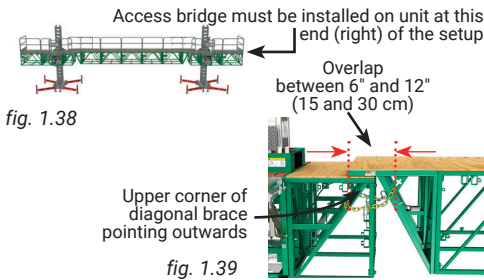

fig. 1.38

Upper corner of diagonal brace pointing outwards
fig. 1.39

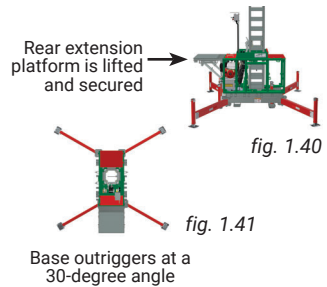

fig. 1.40

fig. 1.41

Base outriggers at a 30-degree angle



To access the work platform by climbing up the mast, it is mandatory to use an access bridge installed on the right-hand side of the mast. In a **twin units configuration**, it is important to make sure that the **access bridge is installed on the motorized unit located the furthest on the right side of the installation**.

Positioning the second motorized unit

- 6- Determine the position of the second motorized unit. To make sure there is sufficient overlap at both ends of the bearing bridge structure, measure the length of the bearing bridge and subtract $9' \times 2 = 18'$ (23 cm $\times 2 = 46$ cm) to obtain the ideal distance between the two motorized units (see fig. 1.39).
- 7- Prepare the second motorized unit and the area where it will be installed.
- 8- Position and install the second motorized unit as described in steps 1 through 21 of the general guidelines, starting on p. 18 of this section.
- 9- Make sure that the rear extension platform is lifted and secured.
- 10- Make sure **all base outriggers are opened at a 30-degree angle**. If base outriggers are required to be parallel to the face of the work (at a 0-degree angle) during the initial stages of installation or if a mast base plate is used, the **first tie level** must be installed **no higher than 10' (3 m) above base level**.
If base outriggers are required to be completely closed during the initial stages of installation, it is **mandatory** to refer to and comply with the *Tie Level Installation Schedule* for an installation using a mast base plate, on p. 102 of the *Accessories* section.
- 11- Make sure that a standard 30" (76 cm) bridge is installed as a cantilever bridge on the end of the unit where the bearing bridge structure will be installed. **The upper corner of the diagonal brace on the cantilever bridge must point outwards**, as shown in fig. 1.39.

Motorized Unit

Methods of Installation

B

Standard twin units configuration – freestanding (requires the use of two bearing bridge adapters – sold separately)

Installation of the bearing bridge structure

- 12- Proceed with the installation of the bearing bridge structure. Refer to p. 52 of the Bridges section for instructions on the assembly and installation of a bearing bridge.

Installation of cantilever bridges

- 13- Proceed with the installation of cantilever bridges on the ends of the motorized units opposite to the bearing bridge structure, as required and allowed. Refer to p. 52 of the *Bridges* section for more information on the installation of a cantilever bridge and to the *Load Capacities* section on p. 73 for the maximum number of bridges allowed in a setup.
- 14- Make sure all required counterweights are in place and secure. For more information about counterweights, refer to the *Load Capacities* section on p. 73.

Connection and testing of the inclinometers

- 15- Plug in the inclinometer at each end of the bearing bridge structure. Test the operation of the inclinometers. Refer to p. 45 of the *Safety Devices* section for more information on the installation, use and testing of inclinometers on a bearing bridge structure. If any of the inclinometers is not working properly, the unit must be put out of service until it has been inspected and repaired by a qualified person. For the definition of a qualified person, refer to p. 7 of the *Performance and Safety Rules* section.

Installation of outriggers and planking

- 16- Adjust the outriggers and install planks, as required and allowed (see p. 90 of the *Accessories* section for more information).

Installation of guardrails

- 17- Before starting to install mast sections, make sure all the required guardrails are in place and secure. In all cases where workers are exposed to fall hazards greater than specified by local regulations, the installation of guardrails or face guardrail supports is **mandatory**. Guardrails must be in place and secure throughout erecting operations. For more information about the installation of guardrails and face guardrail supports, refer to p. 83 of the *Accessories* section.

Installation of mast sections

- 18- Using a crane or a rough terrain forklift, load mast sections on the platform. **Mast sections loaded on the platform must be stored horizontally and distributed equally on either side of each motorized unit to ensure good balance.** Refer to the *Load Capacities* section on p. 73 for more information about loading the platform.
- 19- Install as many mast sections as required until the setup has reached the desired height, equal or inferior to the maximum allowable height for a freestanding installation, making sure throughout the process that each mast remains plumb on both its front and side axis. It is important to install mast sections alternately – one on the first motorized unit, then one on the second, to ensure good balance. For instructions on the installation of a mast section, refer to p. 63 of the *Mast and Mast Ties* section. Refer to p. 66 of the *Mast and Mast Ties* section for more details on the maximum allowable height for a freestanding installation.



CAUTION

When raising or lowering twin motorized units linked by a bearing bridge, any bridge slope must not exceed a maximum of 2° or 1" / 24" (2,5 cm / 61 cm).



NOTICE

A freestanding twin units setup must not be raised over 20' (6,1 m). It is important to note that freestanding bases cannot be used in a setup with twin motorized units linked by a bearing bridge.

- 20- It is important to make sure to verify the mast bolts when lowering the platform to make sure they are in good condition and are tightened properly, especially on **brand-new mast sections**, as the galvanized coating may have compressed. In all cases, mast bolts must be tightened with a torque of 120 lb-ft (163 N-m). Overtightening or undertightening mast bolts may lead to equipment damage.

Motorized Unit

Methods of Installation

Standard twin units configuration – freestanding (requires the use of two bearing bridge adapters – sold separately)

Verification of the setup

- 21- Before passing the installation for use and authorizing workers to use the work platform, make a final verification of the setup and perform every step in the daily inspection checklist on each motorized unit. If required, fill out the handover sheet to complete the installation. Refer to p. 112 of the *Transport, Storage and Maintenance* section for more information about the daily inspection checklist and to p. 115 for information about the handover sheet.

WARNING

It is important to make sure to verify the mast bolts when lowering the platform to make sure they are in good condition and are tightened properly, especially on **brand-new mast sections**, as the galvanized coating may have compressed. In all cases, mast bolts must be tightened with a torque of 120 lb-ft (163 N·m). Overtightening or undertightening mast bolts may lead to equipment damage.

Adding mast sections progressively

- 22- Repeat steps 18 through 21 when it is necessary to install additional mast sections. If required, modify the handover sheet accordingly.

Standard single unit configuration with mast ties – progressive installation

The following installation steps can **only** be used for a **standard configuration**. For the definition of a standard configuration, refer to p. 19 of this section. For instructions on the installation of a non standard single unit configuration with mast ties, refer to method of installation "E", on p. 30 of this section.

Positioning the motorized unit

- 1- Prepare the motorized unit and the area where it will be installed.
- 2- Position and install the motorized unit as described in steps 1 through 21 of the general guidelines, starting on p. 18 of this section.
- 3- Make sure the rear extension platform is lifted and secured. For instructions on how to lift and secure the rear extension platform, refer to p. 17 of this section.
- 4- Make sure the inclinometer bypass is connected. For more information about inclinometers, refer to p. 45 of the *Safety Devices* section.
- 5- Make sure **all base outriggers are opened at a 30-degree angle and remain opened** until at least **two tie levels** have been installed.

If base outriggers are required to be parallel to the face of the work (at a 0-degree angle) during the initial stages of installation or if a mast base plate is used, the **first tie level** must be installed **no higher than 10' (3 m) above base level**.

If base outriggers are required to be completely closed during the initial stages of installation, it is **mandatory** to refer to and comply with the *Tie Level Installation Schedule* for an installation using a mast base plate, on p. 102 of the *Accessories* section.

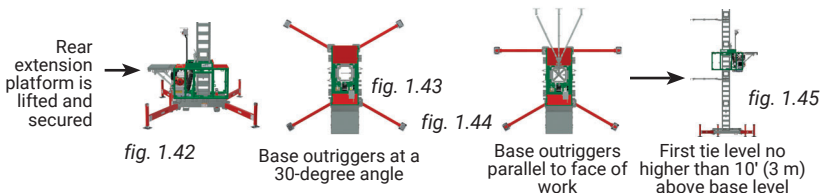

CAUTION

It is important to make sure that **all base outriggers are opened at a 30-degree angle and remain opened** until at least **two tie levels** have been installed. If base outriggers are required to be parallel to the face of the work (at a 0-degree angle) during the initial stages of installation, the **first tie level** must be **installed no higher than 10' (3 m) above base level**; if base outriggers are required to be closed completely, it is **mandatory** to refer to and comply with the *Tie Level Installation Schedule* for an installation using a mast base plate, on p. 102 of the *Accessories* section.

Motorized Unit

Methods of Installation

C Standard single unit configuration with mast ties – progressive installation

Installation of bridges

- 6- Using bridge installation support brackets or any other appropriate lifting device such as a crane or a rough terrain forklift, install as many bridges as is required and allowed. Make sure to install bridges alternately on one side of the mast, then on the other, to ensure stability.

It must be noted that a **bridge attached to the motorized unit** (to the left or right) must be bolted using **eight** bolt assemblies, while only **six** bolt assemblies are required when **bolting two bridges** together.

For instructions on the installation of a bridge, refer to p. 51 of the *Bridges* section. For information on the use of bridge installation support brackets, refer to p. 89 of the *Accessories* section. Refer to the *Load Capacities* section on p. 73 for the maximum number of bridges allowed in a setup.

Installation of outriggers and planking

- 7- Adjust the outriggers and install planks, as required and allowed (see p. 90 of the *Accessories* section for more information).

Installation of guardrails

- 8- Before starting to install mast sections, make sure all the required guardrails are in place and secure. In all cases where workers are exposed to fall hazards greater than specified by local regulations, the installation of guardrails or face guardrail supports is **mandatory**. Guardrails must remain in place and secure throughout erecting operations. For more information about the installation of guardrails and face guardrail supports, refer to p. 83 of the *Accessories* section.

Installation of mast sections and tie levels

- 9- Using a crane or a rough terrain forklift, load mast sections on the platform. **Mast sections loaded on the platform must be stored horizontally and distributed equally on either side of the mast to ensure good balance.** Refer to the *Load Capacities* section on p. 73 for more information about loading the platform.
- 10- Install mast sections until a first tie level is required, making sure throughout the process that the mast remains plumb on both its front and side axis. For instructions on the installation of a mast section, refer to p. 63 of the *Mast and Mast Ties* section. Refer to p. 64 of the *Mast and Mast Ties* section for instructions on how to install mast ties. For more information about the schedule of installation of tie levels, refer to the *Tie Level Installation Schedule* table on p. 66 of the *Mast and Mast Ties* section.
- 11- Once **at least two tie levels** have been installed, the configuration of base outriggers can be modified, if required (set at a 0-angle or closed completely).
- 12- Install as many mast sections as the plan layout requires and as is allowed. A P Series motorized unit setup with mast ties must not be used on a mast with a height over 250' (76 m). Make sure throughout the process that the mast remains plumb on both its front and side axis and that tie levels are installed when required.
- 13- It is important to make sure to verify the mast bolts when lowering the platform to make sure they are in good condition and are tightened properly, especially on **brand-new mast sections**, as the galvanized coating may have compressed. In all cases, mast bolts must be tightened with a torque of 120 lb-ft (163 N-m). Overtightening or undertightening mast bolts may lead to equipment damage.



WARNING

It is important to make sure to verify the mast bolts when lowering the platform to make sure they are in good condition and are tightened properly, especially on **brand-new mast sections**, as the galvanized coating may have compressed. In all cases, mast bolts must be tightened with a torque of 120 lb-ft (163 N-m). Overtightening or undertightening mast bolts may lead to equipment damage.

Verification of the setup

- 14- Before passing the installation for use and authorizing workers to use the work platform, make a final verification of the setup and perform every step in the daily inspection checklist. If required, fill out the handover sheet to complete the installation. Refer to p. 112 of the *Transport, Storage and Maintenance* section for more information about the daily inspection checklist and to p. 115 for information about the handover sheet.

Adding mast sections and tie levels progressively

- 15- Repeat steps 9 through 13 when it is necessary to install additional mast sections and tie levels. If required, modify the handover sheet accordingly.

Motorized Unit

Methods of Installation

Standard twin units configuration with mast ties – progressive installation (requires the use of two bearing bridge adapters – sold separately)

- D** The following installation steps can **only** be used for a **standard configuration**. For the definition of a standard configuration, refer to p. 19 of this section. For instructions on the installation of a non standard twin units configuration with mast ties, refer to method of installation "F", on p. 32 of this section.

Positioning the first motorized unit

- 1- Prepare the first motorized unit and the area where the setup will be installed. If the twin units setup will be equipped with an access bridge, it is important to make sure that this access bridge is installed on the motorized unit located the **furthest on the right side** of the installation (fig. 1.50).
- 2- Position and install the first motorized unit as described in steps 1 through 21 of the general guidelines, starting on p. 18 of this section.
- 3- Make sure the rear extension platform is lifted and secured. For instructions on how to lift and secure the rear extension platform, refer to p. 17 of this section.
- 4- Make sure **all base outriggers are opened at a 30-degree angle** and **remain opened** until at least **two tie levels** have been installed.
If base outriggers are required to be parallel to the face of the work (at a 0-degree angle) during the initial stages of installation, the **first tie level** must be installed **no higher than 10' (3 m) above base level**.
If base outriggers are required to be completely closed during the initial stages of installation, or if mast base plates are used, it is **mandatory** to refer to and comply with the *Tie Level Installation Schedule* for an installation using a mast base plate, on p. 102 of the *Accessories* section.
- 5- Make sure that a standard 30" (76 cm) bridge is installed as a cantilever bridge on the end of the unit where the bearing bridge structure will be installed. **The upper corner of the diagonal brace on the cantilever bridge must point outwards**, as shown in fig. 1.51.

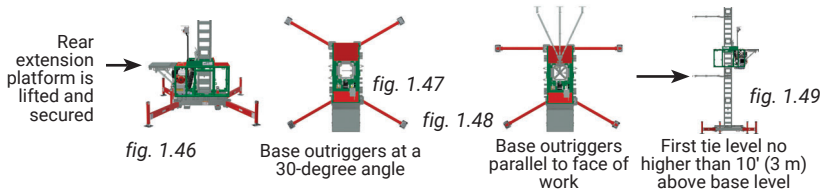

CAUTION

It is important to make sure that **all base outriggers are opened at a 30-degree angle** and **remain opened** until at least **two tie levels** have been installed. If base outriggers are required to be parallel to the face of the work (at a 0-degree angle) during the initial stages of installation, the **first tie level** must be **installed no higher than 10' (3 m) above base level**; if base outriggers are required to be closed completely, it is **mandatory** to refer to and comply with the *Tie Level Installation Schedule* for an installation using a mast base plate, on p. 102 of the *Accessories* section.

Positioning the second motorized unit

- 6- Determine the position of the second motorized unit. To make sure there is sufficient overlap at both ends of the bearing bridge structure, measure the length of the bearing bridge and subtract $9" \times 2 = 18"$ ($23 \text{ cm} \times 2 = 46 \text{ cm}$) to obtain the ideal distance between the two motorized units (see fig. 1.51).

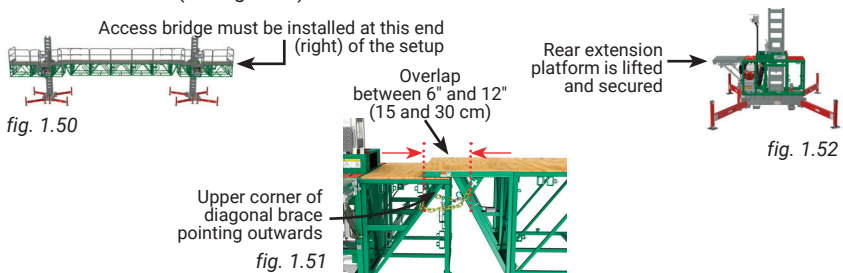

Motorized Unit

Methods of Installation

D Standard twin units configuration with mast ties – progressive installation (requires the use of two bearing bridge adapters – sold separately)

Positioning the second motorized unit (cont'd)

- 7- Prepare the second motorized unit and the area where it will be installed.
- 8- Position and install the second motorized unit as described in steps 1 through 21 of the general guidelines, starting on p. 18 of this section.
- 9- Make sure that the rear extension platform is lifted and secured.
- 10- Make sure **all base outriggers are opened at a 30-degree angle**. If base outriggers are required to be parallel to the face of the work (at a 0-degree angle) during the initial stages of installation or if mast base plate is used, the **first tie level** must be installed **no higher than 10' (3 m) above base level**.
If base outriggers are required to be completely closed during the initial stages of installation, it is **mandatory** to refer to and comply with the *Tie Level Installation Schedule* for an installation using a mast base plate, on p. 102 of the *Accessories* section.
- 11- Make sure that a standard 30" (76 cm) bridge is installed as a cantilever bridge on the end of the unit where the bearing bridge structure will be installed. **The upper corner of the diagonal brace on the cantilever bridge must point outwards**, as shown in fig. 1.51, p. 27.



To access the work platform by climbing up the mast, it is mandatory to use an access bridge installed on the right-hand side of the mast. In a **twin units configuration**, it is important to make sure that this **access bridge is installed on the motorized unit located the furthest on the right side of the installation**.

Installation of the bearing bridge structure

- 12- Proceed with the installation of the bearing bridge structure. Refer to p. 52 of the *Bridges* section for instructions on the assembly and the installation of a bearing bridge structure.

Installation of cantilever bridges

- 13- Proceed with the installation of cantilever bridges on the ends of the motorized units opposite to the bearing bridge structure, as required and allowed. Refer to p. 52 of the *Bridges* section for more information on the installation of a cantilever bridge and to the *Load Capacities* section on p. 73 for the maximum number of bridges allowed in a setup.
- 14- Make sure all required counterweights are in place and secure. For more information about counterweights, refer to the *Load Capacities* section on p. 73.

Connection and testing of the inclinometers

- 15- Plug in the inclinometer at each end of the bearing bridge structure. Test the operation of the inclinometers. Refer to p. 45 of the *Safety Devices* section for more information on the installation, use and testing of inclinometers on a bearing bridge structure. If any of the inclinometers is not working properly, the unit must be put out of service until it has been inspected and repaired by a qualified person. For the definition of a qualified person, refer to p. 7 of the *Performance and Safety Rules* section.

Installation of outriggers and planking

- 16- Adjust the outriggers and install planks, as required and allowed (see p. 90 of the *Accessories* section for more information).

Installation of guardrails

- 17- Before starting to install mast sections, make sure all the required guardrails are in place and secure. In all cases where workers are exposed to fall hazards greater than specified by local regulations, the installation of guardrails or face guardrail supports is **mandatory**. Guardrails must remain in place and secure throughout erecting operations. For more information about the installation of guardrails and face guardrail supports, refer to p. 83 of the *Accessories* section.

Installation of mast sections and tie levels

- 18- Using a crane or a rough terrain forklift, load mast sections on the platform. **Mast sections loaded on the platform must be stored horizontally and distributed equally on either side of each mast to ensure good balance**. Refer to the *Load Capacities* section on p. 73 for more information about loading the platform.

Motorized Unit

Methods of Installation

Standard twin units configuration with mast ties – progressive installation (requires the use of two bearing bridge adapters – sold separately)



Installation of mast sections and tie levels (cont'd)

- 19- Install mast sections until a first tie level is required, making sure throughout the process that each mast remains plumb on both its front and side axis. It is important to install mast sections alternately – one on the first motorized unit, then one on the second, to ensure good balance. For instructions on the installation of a mast section, refer to p. 63 of the *Mast and Mast Ties* section. Refer to p. 64 of the *Mast and Mast Ties* section for instructions on how to install mast ties. For more information about the schedule of installation of tie levels, refer to the *Tie Level Installation Schedule* table on p. 66 of the *Mast and Mast Ties* section.
- 20- Once **at least two tie levels** have been installed, the configuration of base outriggers can be modified, if required (set at a 0-angle or closed completely).
- 21- Install as many mast sections as the plan layout requires and as is allowed. A P Series motorized unit setup with mast ties must not be used on a mast with a height over 250' (76 m) Make sure throughout the process that each mast remains plumb on both its front and side axis and that tie levels are installed when required.
- 22- It is important to make sure to verify the mast bolts when lowering the platform to make sure they are in good condition and are tightened properly, especially on **brand-new mast sections**, as the galvanized coating may have compressed. In all cases, mast bolts must be tightened with a torque of 120 lb-ft (163 N-m). Overtightening or undertightening mast bolts may lead to equipment damage.



WARNING

It is important to make sure to verify the mast bolts when lowering the platform to make sure they are in good condition and are tightened properly, especially on **brand-new mast sections**, as the galvanized coating may have compressed. In all cases, mast bolts must be tightened with a torque of 120 lb-ft (163 N-m). Overtightening or undertightening mast bolts may lead to equipment damage.

Verification of the setup

- 23- Before passing the installation for use and authorizing workers to use the work platform, make a final verification of the setup and perform every step in the daily inspection checklist on each motorized unit. If required, fill out the handover sheet to complete the installation. Refer to p. 112 of the *Transport, Storage and Maintenance* section for more information about the daily inspection checklist and to p. 115 for information about the handover sheet.

Adding mast sections and tie levels progressively

- 24- Repeat steps 18 through 22 when it is necessary to install additional mast sections and tie levels. If required, modify the handover sheet accordingly.



CAUTION

When raising or lowering twin motorized units linked by a bearing bridge, any bridge slope must not exceed a maximum of 2° or 1" / 24" (2,5 cm / 61 cm).

Motorized Unit Methods of Installation

Non standard single unit configuration – pre-installation of tie levels

E

The following installation steps must be used for a **non standard single unit configuration**. Refer to the box below for the definition of a non standard configuration. This method can also be used to pre-install the tie levels for a standard configuration. For instructions on the progressive installation of a **standard** single unit configuration with mast ties, refer to method of installation “C”, on p. 25 of this section. In a **non standard configuration**, the **pre-installation of all required mast sections and tie levels** to reach the total mast height specified in the layout plan is **mandatory**.

N

NOTICE

Non-standard configurations must be installed in standard configuration: any authorized equipment or accessory must be installed **only once all required mast sections and tie levels are in place**.

In a non standard configuration, it is **mandatory** to **pre-install all required mast sections and tie levels** to reach the total mast height specified in the layout plan **before starting any work**.

Definition of the pre-installation of a setup

The **pre-installation of a setup**, referred to throughout this owner's manual and related documentation, consists in **installing all required mast sections and tie levels to reach the total mast height specified in the layout plan before installing any additional equipment or accessory and before starting any work**.

It is **mandatory** to use this method for any non standard configuration.

Definition of a non standard configuration

A **non standard configuration**, referred to throughout this owner's manual and related documentation, is an installation **requiring** the use of **angled or non-linear equipment**, such as a front/rear extension bridge, a swivel bridge, or a planking configuration wider than three planks, **or an accessory** such as weather protection, a monorail or a hoist support structure with a hoist. Freestanding is not allowed for a non standard configuration. It is **mandatory to pre-install all required mast sections and tie levels to reach the total mast height specified in the layout plan** when using a non standard configuration. It is mandatory to refer to the *Load Capacities* section on p. 73 for the number of bridges allowed in a non standard single unit or twin units installation.

Positioning the motorized unit

- 1- Prepare the motorized unit and the area where the it will be installed.
- 2- Position and install the motorized unit as described in steps 1 through 21 of the general guidelines, starting on p. 18 of this section.
- 3- Make sure the rear extension platform is lifted and secured. For instructions on how to lift and secure the rear extension platform, refer to p. 17 of this section.
- 4- Make sure the inclinometer bypass is connected. For more information about inclinometers, refer to p. 45 of the *Safety Devices* section.
- 5- Make sure **all base outriggers are opened at a 30-degree angle and remain opened** until at least **two tie levels** have been installed.

If base outriggers are required to be parallel to the face of the work (at a 0-degree angle) during the initial stages of installation or if a mast base plate is used, the **first tie level** must be installed **no higher than 10' (3 m) above base level**.

If base outriggers are required to be completely closed during the initial stages of installation, it is **mandatory** to refer to and comply with the *Tie Level Installation Schedule* for an installation using a mast base plate, on p. 102 of the *Accessories* section.

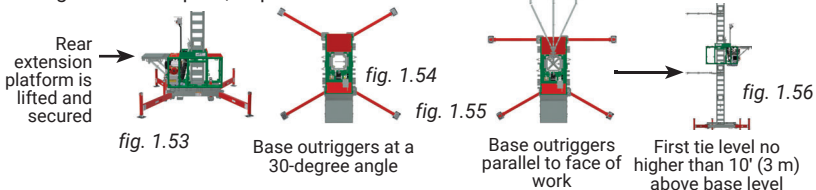

CAUTION

It is important to make sure that **all base outriggers are opened at a 30-degree angle** until at least **two tie levels** have been installed. If base outriggers are required to be parallel to the face of the work (at a 0-degree angle) during the initial stages of installation, the **first tie level** must be installed **no higher than 10' (3 m) above base level**; if base outriggers are required to be closed completely, it is **mandatory** to refer to and comply with the *Tie Level Installation Schedule* for an installation using a mast base plate, on p. 102 of the *Accessories* section.

Motorized Unit

Methods of Installation

Non standard single unit configuration – pre-installation of tie levels



Installation of bridges

- 6- Using bridge installation support brackets or any other appropriate lifting device such as a crane or a rough terrain forklift, install as many bridges as is required and allowed. Make sure to install bridges alternately on one side of the mast, then on the other, to ensure stability. It must be noted that a **bridge attached to the motorized unit** (to the left or right) must be bolted using **eight** bolt assemblies, while only **six** bolt assemblies are required when **bolting two bridges** together.

For more information about bridge installation, refer to p. 51 of the *Bridges* section. For information on the use of bridge installation support brackets, refer to p. 89 of the *Accessories* section. Refer to the *Load Capacities* section on p. 73 for the maximum number of bridges allowed in a setup.

Installation of outriggers and planking for tie installation only

- 7- Install **only** the outriggers and the planking required in front of the mast for tie installation. For information about the installation of outriggers, refer to p. 90 of the *Accessories* section.

Installation of guardrails

- 8- Before starting to install mast sections, make sure all the required guardrails are in place and secure. In all cases where workers are exposed to fall hazards greater than specified by local regulations, the installation of guardrails or face guardrail supports is **mandatory**. Guardrails must remain in place and secure throughout erecting operations. For more information about the installation of guardrails and face guardrail supports, refer to p. 83 of the *Accessories* section.

N	NOTICE
During pre-installation, only mast sections can be loaded on the platform until the process is complete.	

Installation of mast sections and tie levels

- 9- Using a crane or a rough terrain forklift, load mast sections on the platform. **Mast sections loaded on the platform must be stored horizontally and distributed equally on either side of the mast to ensure good balance.** Refer to the *Load Capacities* section on p. 73 for more information about loading the platform.
- 10- Install mast sections until a first tie level is required, making sure throughout the process that the mast remains plumb on both its front and side axis. For instructions on the installation of a mast section, refer to p. 63 of the *Mast and Mast Ties* section. Refer to p. 64 of the *Mast and Mast Ties* section for instructions on how to install mast ties. For more information about the schedule of installation of tie levels, refer to the *Tie Level Installation Schedule* table on p. 66 of the *Mast and Mast Ties* section.
- 11- Once **at least two tie levels** have been installed, the configuration of base outriggers can be modified, if required (set at a 0-angle or closed completely).
- 12- Install as many mast sections as the plan layout requires and as is allowed. A P Series motorized unit setup with mast ties must not be used on a mast with a height over 250' (76 m). Make sure throughout the process that the mast remains plumb on both its front and side axis and that tie levels are installed when required.
- 13- It is important to make sure to verify the mast bolts when lowering the platform to make sure they are in good condition and are tightened properly, especially on **brand-new mast sections**, as the galvanized coating may have compressed. In all cases, mast bolts must be tightened with a torque of 120 lb-ft (163 N-m). Overtightening or undertightening mast bolts may lead to equipment damage.

	WARNING
It is important to make sure to verify the mast bolts when lowering the platform to make sure they are in good condition and are tightened properly, especially on brand-new mast sections , as the galvanized coating may have compressed. In all cases, mast bolts must be tightened with a torque of 120 lb-ft (163 N-m). Overtightening or undertightening mast bolts may lead to equipment damage.	

Motorized Unit

Methods of Installation

E Non standard single unit configuration – pre-installation of tie levels

Installation of an accessory or a non-linear equipment

14- Once all the required mast sections and tie levels to reach the total mast height specified in the layout plan have been installed, make sure the motorized unit is at base level and install the accessory or the non-linear equipment required. It is important to note that **only one** accessory or **one** non-linear equipment is allowed per installation.

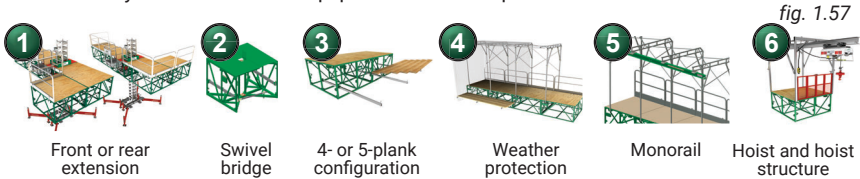

15- Refer to the *Bridges* section for instructions on the installation of a front or rear extension (p. 54) or a swivel bridge (p. 56). Refer to the *Accessories* section, for instructions on the installation of a 4- or 5-plank configuration (p. 90), weather protection (p. 106), a monorail (p. 107) or a hoist support structure (p. 105).

Completing the installation of outriggers and planking

16- Install the remaining outriggers and planking, as is required and allowed.

Verification of the setup

17- Before passing the installation for use and authorizing workers to use the work platform, make a final verification of the setup and perform every step in the daily inspection checklist. If required, fill out the handover sheet to complete the installation. Refer to p. 112 of the *Transport, Storage and Maintenance* section for more information about the daily inspection checklist and to p. 115 for information about the handover sheet.

Non standard twin units configuration – pre-installation of tie levels

F

The following installation steps can be used for a **non standard twin units configuration**. Refer to the box below for the definition of a non standard configuration. This method can also be used to pre-install the tie levels for a standard configuration. For instructions on the progressive installation of a **standard** twin units configuration with mast ties, refer to method of installation “D”, on p. 27 of this section. In a **non standard configuration**, the **pre-installation of all required mast sections and tie levels to reach the total mast height specified in the layout plan is mandatory**.

N

NOTICE

Non-standard configurations must be installed in standard configuration: any authorized equipment or accessory must be installed only once all required mast sections and tie levels are in place.

In a non standard configuration, it is **mandatory to pre-install all required mast sections and tie levels to reach the total mast height specified in the layout plan before starting any work.**

Definition of the pre-installation of a setup

The **pre-installation of a setup**, referred to throughout this owner's manual and related documentation, consists in **installing all required mast sections and tie levels to reach the total mast height specified in the layout plan before installing any additional equipment or accessory and before starting any work.**

It is **mandatory** to use this method for any non standard configuration.

Positioning the first motorized unit

- 1- Prepare the first motorized unit and the area where it will be installed. If the twin units setup will be equipped with an access bridge, it is important to make sure that this access bridge is installed on the motorized unit located the **furthest** on the **right side** of the installation (fig. 1.62, p. 33)
- 2- Position and install the first motorized unit described in steps 1 through 21 of the general guidelines, starting on p. 18 of this section.

Motorized Unit

Methods of Installation

Non standard twin units configuration – pre-installation of tie levels

F

Definition of a non standard configuration

A **non standard configuration**, referred to throughout this owner's manual and related documentation, is an installation **requiring** the use of **angled or non-linear equipment**, such as a front/rear extension bridge, a swivel bridge, or a planking configuration wider than three planks, **or an accessory** such as weather protection, a monorail or a hoist support structure with a hoist. Freestanding is not allowed for a non standard configuration. It is **mandatory to pre-install all required mast sections and tie levels to reach the total mast height specified in the layout plan** when using a non standard configuration. It is mandatory to refer to the *Load Capacities* section on p. 73 for the number of bridges allowed in a non standard single unit or twin units installation.

Positioning the first motorized unit (cont'd)

- 3- Make sure the rear extension platform is lifted and secured. For instructions on how to lift and secure the rear extension platform, refer to p. 17 of this section.
- 4- Make sure **all base outriggers are opened** at a **30-degree angle** and **remain opened** until at least **two tie levels** have been installed.

If base outriggers are required to be parallel to the face of the work (at a 0-degree angle) during the initial stages of installation or if a mast base plate is used, the **first tie level** must be installed **no higher than 10' (3 m) above base level**.

If base outriggers are required to be completely closed during the initial stages of installation, it is **mandatory** to refer to and comply with the *Tie Level Installation Schedule* for an installation using a mast base plate, on p. 102 of the *Accessories* section.

- 5- Make sure that a standard 30" (76 cm) bridge is installed as a cantilever bridge on the end of the unit where the bearing bridge structure will be installed. **The upper corner of the diagonal brace on the cantilever bridge must point outwards**, as shown in fig. 1.63.

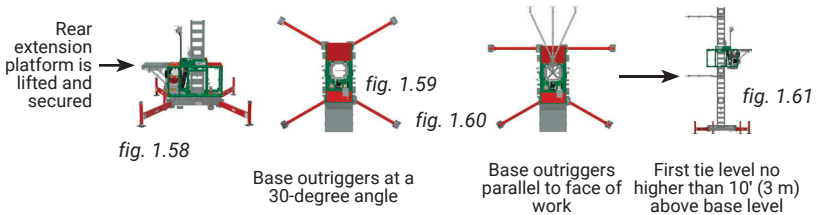

CAUTION

It is important to make sure that **all base outriggers are opened at a 30-degree angle** and **remain opened** until at least **two tie levels** have been installed. If base outriggers are required to be parallel to the face of the work (at a 0-degree angle) during the initial stages of installation, the **first tie level** must be **installed no higher than 10' (3 m) above base level**; if base outriggers are required to be closed completely, it is **mandatory** to refer to and comply with the *Tie Level Installation Schedule* for an installation using a mast base plate, on p. 102 of the *Accessories* section.

Positioning the second motorized unit

- 6- Determine the position of the second motorized unit. To make sure there is sufficient overlap at both ends of the bearing bridge structure, measure the length of the bearing bridge and subtract $9'' \times 2 = 18''$ (23 cm \times 2 = 46 cm) to obtain the ideal distance between the two motorized units (see fig. 1.63).

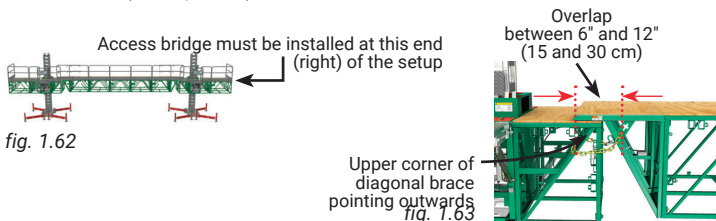

Motorized Unit

Methods of Installation

F Non standard twin units configuration – pre-installation of tie levels

Positioning the second motorized unit (cont'd)

- 7- Prepare the second motorized unit and the area where it will be installed.
- 8- Position and install the second motorized unit as described in steps 1 through 21 of the general guidelines, starting on p. 18 of this section.
- 9- Make sure that the rear extension platform is lifted and secured. Make sure all base outriggers are opened at a 30-degree angle.
- 10- Make sure that a standard 30" (76 cm) bridge is installed as a cantilever bridge on the end of the unit where the bearing bridge structure will be installed. **The upper corner of the diagonal brace on the cantilever bridge must point outwards**, as shown in fig. 1.63.



To access the work platform by climbing up the mast, it is mandatory to use an access bridge installed on the right-hand side of the mast. In a **twin units configuration**, it is important to make sure that this **access bridge is installed on the motorized unit located the furthest on the right side of the installation.**

Installation of the bearing bridge structure

- 11- Proceed with the installation of the bearing bridge structure. Refer to p. 52 of the *Bridges* section for instructions on the assembly and installation of a bearing bridge structure.

Installation of cantilever bridges

- 12- Proceed with the installation of cantilever bridges on the ends of the motorized units opposite to the bearing bridge structure, as required and allowed. Refer to p. 52 of the *Bridges* section for instructions on the installation of a cantilever bridge and to the *Load Capacities* section on p. 73 for the maximum number of bridges allowed in a setup.
- 13- Make sure all required counterweights are in place and secure. For more information about counterweights, refer to the *Load Capacities* section on p. 73.

Connection and testing of the inclinometers

- 14- Plug in the inclinometers at both ends of the bearing bridge structure. Test the operation of the inclinometers. Refer to p. 45 of the *Safety Devices* section for more information on the installation, use and testing of inclinometers on a bearing bridge structure. If any of the inclinometers is not working properly, the unit must be put out of service until it has been inspected and repaired by a qualified person. For the definition of a qualified person, refer to p. 7 of the *Performance and Safety Rules* section.

Installation of outriggers and planking for tie installation only

- 15- Install **only** the outriggers and the planking required in front of the mast for tie installation. For information about the installation of outriggers, refer to p. 90 of the *Accessories* section.

Installation of guardrails

- 16- Before starting to install mast sections, make sure all the required guardrails are in place and secure. In all cases where workers are exposed to fall hazards greater than specified by local regulations, the installation of guardrails or face guardrail supports is **mandatory**. Guardrails must remain in place and secure throughout erecting operations. For more information about the installation of guardrails and face guardrail supports, refer to p. 83 of the *Accessories* section.

Installation of mast sections and tie levels

- 17- Using a crane or a rough terrain forklift, load mast sections on the platform. **Mast sections loaded on the platform must be stored horizontally and distributed equally on either side of each mast to ensure good balance.** Refer to the *Load Capacities* section on p. 73 for more information about loading the platform.
- 18- Install mast sections until a first tie level is required, making sure throughout the process that each mast remains plumb on both its front and side axis. It is important to install mast sections alternately – one on the first motorized unit, then one on the second, to ensure good balance. For instructions on the installation of a mast section, refer to p. 63 of the *Mast and Mast Ties* section. Refer to p. 64 of the *Mast and Mast Ties* section for instructions on how to install mast ties. For more information about the schedule of installation of tie levels, refer to the *Tie Level Installation Schedule* table on p. 66 of the *Mast and Mast Ties* section.

Motorized Unit

Methods of Installation

Non standard twin units configuration – pre-installation of tie levels



NOTICE

In a non standard configuration, it is **mandatory** to **pre-install all required mast sections and tie levels** to reach the total mast height specified in the layout plan **before starting any work**.



NOTICE

During pre-installation, only mast sections can be loaded on the platform until the process is complete.

Installation of mast sections and tie levels (cont'd)

- 19- Once **at least two tie levels** have been installed on each motorized unit, the configuration of base outriggers can be modified, if required (set at a 0-angle or closed completely).
- 20- Install as many mast sections as the plan layout requires and as is allowed. A P Series motorized unit setup with mast ties must not be used on a mast with a height over 250' (76 m). Make sure throughout the process that each mast remains plumb on both its front and side axis and that tie levels are installed when required.
- 21- It is important to make sure to verify the mast bolts when lowering the platform to make sure they are in good condition and are tightened properly, especially on **brand-new mast sections**, as the galvanized coating may have compressed. In all cases, mast bolts must be tightened with a torque of 120 lb-ft (163 N-m). Overtightening or undertightening mast bolts may lead to equipment damage.



WARNING

It is important to make sure to verify the mast bolts when lowering the platform to make sure they are in good condition and are tightened properly, especially on **brand-new mast sections**, as the galvanized coating may have compressed. In all cases, mast bolts must be tightened with a torque of 120 lb-ft (163 N-m). Overtightening or undertightening mast bolts may lead to equipment damage.

Installation of an accessory or a non-linear equipment

- 22- Once all the required mast sections and tie levels to reach the total height specified by the layout plan for each mast have been installed, make sure the motorized units are at base level and install the accessory or the non-linear equipment required. It is important to note that **only one** accessory or **one** non-linear equipment is allowed per installation.

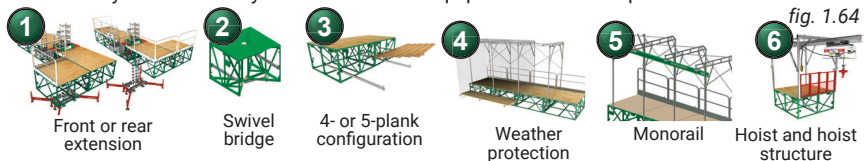

- 23- Refer to the *Bridges* section for instructions on the installation of a front or rear extension (p. 54) or a swivel bridge (p. 56). Refer to the *Accessories* section, for instructions on the installation of a 4- or 5-plank configuration (p. 90), weather protection (p. 106), a monorail (p. 107) or a hoist support structure (p. 105).

Completing the installation of outriggers and planking

- 24- Install the remaining outriggers and planking, as is required and allowed.

Verification of the setup

- 25- Before passing the installation for use and authorizing workers to use the work platform, make a final verification of the setup and perform every step in the daily inspection checklist on each motorized unit. If required, fill out the handover sheet to complete the installation. Refer to p. 112 of the *Transport, Storage and Maintenance* section for more information about the daily inspection checklist and to p. 115 for information about the handover sheet.



CAUTION

When raising or lowering twin motorized units linked by a bearing bridge, any bridge slope must not exceed a maximum of 2° or 1" / 24" (2,5 cm / 61 cm).

Motorized Unit

Dismantling an Installation



SAFETY comes first. It is essential that the **dismantling** of a P Series motorized unit setup be carried out by **qualified erectors/dismantlers** under the supervision of a **competent person** and be performed with the same care and precaution taken during the installation. The use of fall protection is **mandatory** for erectors/dismantlers during the dismantling of a setup.

It is mandatory to make sure that the motorized unit installation remains stable and secure throughout the dismantling operations. For the definition of a qualified erector/dismantler or a competent person, refer to p. 7 of the *Performance and Safety Rules* section.

For each setup and configuration, a job/task-specific dismantling procedure for any Hydro Mobile equipment used must be compiled in consultation with and approved by a qualified person before proceeding with the dismantling of the equipment.

Safety guidelines for dismantling an installation

- 1- Make sure all loads have been removed from the platform.
- 2- Make sure all the equipment necessary for a safe dismantling of the installation is on hand (slings, crane or rough terrain forklift, etc., as required).

Preparing the installation for dismantling

- 3- In reference to the job survey/job hazard analysis, the layout plan, the selected configuration and the job/task-specific dismantling procedure, determine if there are obstacles or hazards.
- 4- Inspect all safety devices (safety hooks, emergency descent, inclinometers if the installation is a twin units configuration, etc.) and make sure they are working properly.
- 5- Make sure that cribbing is in place and in good condition.
- 6- It is important to make sure that **all guardrails required for the configuration are in place and secure**. Guardrails must remain in place and secure throughout dismantling operations. For more information about the installation of guardrails and face guardrail supports, refer to p. 83 of the *Accessories* section.
- 7- **Make sure that the base outrigger configuration is appropriate for the installation.**
- 8- Make sure to choose the appropriate method for dismantling the installation. For more information about standard and non standard configurations, refer to p. 18 of this section. For instructions on the dismantling of an installation using an adapter base for sidewalk canopy installation, refer to p. 100 of the *Accessories* section. For an installation using a mast base plate, refer to p. 102 of the *Accessories* section for dismantling guidelines.
- 9- For a **non standard configuration**, make sure the **additional equipment or accessory has been uninstalled properly before starting dismantling operations**. Refer to appropriate dismantling instructions for each equipment or accessory to remove.
- 10- Perform every step in the daily inspection checklist. Refer to p. 112 of the *Transport, Storage and Maintenance* section for more information about the daily inspection checklist.
- 11- Bring the motorized unit(s) to the top of the work, verifying mast bolts and mast ties on the way up. Make sure that all mast bolts are tightened properly and that mast ties are properly tied to the face of the work.



CAUTION

Before starting to dismantle any **non standard configuration**, make sure to remove any installed additional equipment or accessory for the setup to meet the conditions for a standard, linear configuration.

Definition of a non standard configuration

A **non standard configuration**, referred to throughout this owner's manual and related documentation, is an installation **requiring** the use of **angled or non-linear equipment**, such as a front/rear extension bridge, a swivel bridge, or a planking configuration wider than three planks, **or an accessory** such as weather protection, a monorail or a hoist support structure with a hoist. Freestanding is not allowed for a non standard configuration. It is **mandatory to pre-install all required mast sections and tie levels to reach the total mast height specified in the layout plan** when using a non standard configuration. It is mandatory to refer to the *Load Capacities* section on p. 73 for the number of bridges allowed in a non standard single unit or twin units installation.

Motorized Unit

Dismantling an Installation

Dismantling a standard single unit configuration – freestanding



The following dismantling steps can **only** be used to dismantle a **standard single unit configuration** installed following method of installation "A". Refer to p. 21 of this section for more information about method of installation "A".

Preparing the installation

- 1- Prepare the installation as described in the safety guidelines and preparation instructions for dismantling a P Series installation on p. 36 of this section.
- 2- Make sure the motorized unit is at the top of the work.

Removing mast sections

- 3- Lower the motorized unit to base level, removing mast sections on the way down. Refer to p. 63 of the *Mast and Mast Ties* section for instructions on how to remove and transport mast sections.

Mast sections loaded on the platform must be stored horizontally and distributed equally on either side of the mast to ensure good balance.

Make sure to avoid overloading the platform. On higher installations, it may be required to use a crane to remove mast sections from the platform to avoid any overloads. Refer to the *Load Capacities* section on p. 73 for more information about loads allowed on an installation.

Removing planking, outriggers and guardrails

- 4- Once at base level, remove all loads from the platform and make all workers step down.
- 5- Remove all planking, push in all outriggers and secure in place. Remove and store all guardrails. For instructions on the removal and storage of guardrails, refer to p. 109 of the *Transport, Storage and Maintenance* section.

Removing access stairs, cantilever bridges and access bridge

- 6- If required, remove the access stairs. Clean and store the access stairs components properly. For instructions on the storage of the access stairs, refer to p. 110 of the *Transport, Storage and Maintenance* section.
- 7- Remove all installed cantilever bridges, leaving no more than one 30" (76 cm) bridge installed at each end of the motorized unit. Make sure to remove bridges alternately on one side of the mast, then on the other, to ensure stability. Clean and store bridges properly. For instructions on the storage of a bridge, refer to p. 109 of the *Transport, Storage and Maintenance* section.
- 8- If required, remove the access bridge. Clean and store the access bridge components properly. For instructions on the storage of the access bridge, refer to p. 110 of the *Transport, Storage and Maintenance* section.

Storage of the motorized unit

- 9- Remove and store the jacks used for the base outriggers. Close all base outriggers.
- 10- If the unit is to be stored for any significant length of time, refer to p. 110 of the *Transport, Storage and Maintenance* section for instructions on how to properly store a P Series motorized unit.

Motorized Unit

Dismantling an Installation

Dismantling a standard twin units configuration – freestanding



The following dismantling steps can **only** be used to dismantle a **standard twin units configuration** installed following method of installation “B”. Refer to p. 23 of this section for more information about method of installation “B”.

Preparing the installation

- 1- Prepare the installation as described in the safety guidelines and preparation instructions for dismantling a P Series installation, on p. 36 of this section.
- 2- Make sure the motorized units are at the top of the work.

Removing mast sections

- 3- Lower the twin motorized units linked by a bearing bridge until the units are two rungs (20" or 50 cm) above base level, removing mast sections on the way down. Refer to p. 63 of the *Mast and Mast Ties* section for instructions on how to remove and transport mast sections.

To make sure that the installation remains stable, remove mast sections alternately – one on one motorized unit, then one on the other. **Mast sections loaded on the platform must be stored horizontally and distributed equally on either side of each mast to ensure good balance.**

Make sure to avoid overloading the platform. On higher installations, it may be required to use a crane to remove mast sections from the platform to avoid any overloads. Refer to the *Load Capacities* section on p. 73 for more information about loads allowed on an installation.

Removing planking, outriggers and guardrails

- 4- Once the units are two rungs above base level, remove all loads from the platform and make workers step down.
- 5- Remove all planking, push in all outriggers and secure in place. Remove and store all guardrails. For instructions on the removal and storage of guardrails, refer to p. 109 of the *Transport, Storage and Maintenance* section.

Removing access stairs, cantilever bridges and access bridge

- 6- If required, remove the access stairs. Clean and store the access stairs components properly. For instructions on the storage of the access stairs, refer to p. 110 of the *Transport, Storage and Maintenance* section.
- 7- First remove all installed cantilever bridges, leaving no more than one 30" (76 cm) bridge installed at each end of the twin units installation. Make sure to remove bridges alternately on one side of the mast, then on the other, to ensure stability. Clean and store bridges properly. For instructions on the storage of a bridge, refer to p. 109 of the *Transport, Storage and Maintenance* section.
- 8- If required, remove the access bridge. Clean and store the access bridge components properly. For instructions on the storage of the access bridge, refer to p. 110 of the *Transport, Storage and Maintenance* section.

Removing the bearing bridge structure

- 9- Disconnect both inclinometers and reconnect the bypass connections. For instructions on the disconnection of an inclinometer and the bypass connection, refer to p. 45 of the *Safety Devices* section.
- 10- Proceed with the dismantling of the bearing bridge structure. For instructions on how to dismantle a bearing bridge structure, refer to p. 54 of the *Bridges* section.

Storage of the motorized units

- 11- Lower both motorized units to base level. Remove and store the jacks used for the base outriggers on each motorized unit.
- 12- Close all base outriggers on both motorized units.
- 13- If any of the motorized units is to be stored for any significant length of time, refer to p. 110 of the *Transport, Storage and Maintenance* section for instructions on how to properly store a P Series motorized unit.

Motorized Unit

Dismantling an Installation

Dismantling a standard single unit configuration with mast ties



The following dismantling steps can **only** be used to dismantle a **standard single unit configuration with mast ties** installed following method of installation "C". Refer to p. 25 of this section for more information about method of installation "C". For instructions on the dismantling of a non standard single unit configuration with mast ties, refer to method of dismantling "E", on p. 41 of this section.

Preparing the installation

- 1- Prepare the installation as described in the safety guidelines and preparation instructions for dismantling a P Series installation on p. 36 of this section.
- 2- Make sure the motorized unit is at the top of the work.

Removing mast sections and tie levels

- 3- Lower the motorized unit to base level, removing mast sections and tie levels on the way down, **leaving the last two tie levels in place**. Refer to p. 63 of the *Mast and Mast Ties* section for instructions on how to remove and transport mast sections. Refer to p. 67 of the *Mast and Mast Ties* section for instructions on how to remove tie levels.

Mast sections loaded on the platform must be stored horizontally and distributed equally on either side of the mast to ensure good balance.

Make sure to avoid overloading the platform. On higher installations, it may be required to use a crane to remove mast sections from the platform to avoid any overloads. Refer to the *Load Capacities* section on p. 73 for more information about loads allowed on an installation.

Removing the last two tie levels

- 4- **With the last two tie levels still in place**, make sure that **all base outriggers are opened at a 30-degree angle**. If base outriggers must be parallel to the face of the work, make sure that the **lowest (last) tie level is no higher than 10' (3 m) above base level**. If necessary, install a tie level at 10' (3 m) above base level.

If base outriggers are required to be completely closed during dismantling or if the base of the motorized unit was replaced by a mast base plate, it is **mandatory** to refer to and comply with the dismantling instructions for an installation with a mast base plate, on p. 102 of the *Accessories* section.

- 5- Once the stability of the motorized unit has been secured, remove the last two tie levels and the remaining mast sections.

Removing planking, outriggers and guardrails

- 6- Once at base level, remove all loads from the platform and make all workers step down.
- 7- Remove all planking, push in all outriggers and secure in place. Remove and store all guardrails. For instructions on the removal and storage of guardrails, refer to p. 109 of the *Transport, Storage and Maintenance* section.

Removing access stairs, cantilever bridges and access bridge

- 8- If required, remove the access stairs. Clean and store the access stairs components properly. For instructions on the storage of the access stairs, refer to p. 110 of the *Transport, Storage and Maintenance* section.
- 9- Remove all installed cantilever bridges, leaving no more than one 30" (76 cm) bridge installed at each end of the motorized unit. Make sure to remove bridges alternately on one side of the mast, then on the other, to ensure stability. Clean and store bridges properly. For instructions on the storage of a bridge, refer to p. 109 of the *Transport, Storage and Maintenance* section.
- 10- If required, remove the access bridge. Clean and store the access bridge components properly. For instructions on the storage of the access bridge, refer to p. 110 of the *Transport, Storage and Maintenance* section.

Storage of the motorized unit

- 11- Remove and store the jacks used for the base outriggers. Close all base outriggers.
- 12- If the unit is to be stored for any significant length of time, refer to p. 110 of the *Transport, Storage and Maintenance* section for instructions on how to properly store a P Series motorized unit.

Motorized Unit

Dismantling an Installation

Dismantling a standard twin units configuration with mast ties

D The following dismantling steps can **only** be used to dismantle a **standard twin units configuration with mast ties** installed following method of installation "D". Refer to p. 27 of this section for more information about method of installation "D". For instructions on the dismantling of a non standard twin units configuration with mast ties, refer to method of dismantling "F", on p. 43 of this section.

Preparing the installation

- 1- Prepare the installation as described in the safety guidelines and preparation instructions for dismantling a P Series installation on p. 36 of this section.
- 2- Make sure the motorized units are at the top of the work.

Removing mast sections and tie levels

- 3- Lower the twin motorized units linked by a bearing bridge, removing mast sections and tie levels on the way down, **leaving the last two tie levels in place on each mast**. To make sure that the installation remains stable, remove mast sections alternately – one on one motorized unit, then one on the other. Refer to p. 63 of the *Mast and Mast Ties* section for instructions on how to remove and transport mast sections. Refer to p. 67 of the *Mast and Mast Ties* section for instructions on how to remove mast ties.

Mast sections loaded on the platform must be stored horizontally and distributed equally on either side of each mast to ensure good balance.

Make sure to avoid overloading the platform. On higher installations, it may be required to use a crane to remove mast sections from the platform to avoid any overloads. Refer to the *Load Capacities* section on p. 73 for more information about loads allowed on an installation.

Removing the last two tie levels

- 4- **With the last two tie levels still in place**, make sure that **all base outriggers are opened at a 30-degree angle**. If base outriggers must be parallel to the face of the work, make sure that the **lowest (last) tie level is no higher than 10' (3 m) above base level**. If necessary, install a tie level at 10' (3 m) above base level.

If base outriggers are required to be completely closed during dismantling or if the base of the motorized unit was replaced by a mast base plate, it is **mandatory** to refer to and comply with the dismantling instructions for an installation with a mast base plate, on p. 102 of the *Accessories* section.

- 5- Once the stability of both motorized units has been secured, remove the last two tie levels on each mast and the remaining mast sections.

Removing planking, outriggers and guardrails

- 6- Lower the twin motorized units linked by a bearing bridge until the units are two rungs (20" or 50 cm) above base level.
- 7- Remove all loads from the platform and make workers step down.
- 8- Remove all planking, push in all outriggers and secure in place. Remove and store all guardrails. For instructions on the removal and storage of guardrails, refer to p. 109 of the *Transport, Storage and Maintenance* section.

Removing access stairs, cantilever bridges and access bridge

- 9- If required, remove the access stairs. Clean and store the access stairs components properly. For instructions on the storage of the access stairs, refer to p. 110 of the *Transport, Storage and Maintenance* section.
- 10- First remove all installed cantilever bridges, leaving no more than one 30" (76 cm) bridge installed at each end of the twin units installation. Make sure to remove bridges alternately on one side of the mast, then on the other, to ensure stability. Clean and store bridges properly. For instructions on the storage of a bridge, refer to p. 109 of the *Transport, Storage and Maintenance* section.
- 11- If required, remove the access bridge. Clean and store the access bridge components properly. For instructions on the storage of the access bridge, refer to p. 110 of the *Transport, Storage and Maintenance* section.

Motorized Unit

Dismantling an Installation

Dismantling a standard twin units configuration with mast ties

D

Removing the bearing bridge structure

- 12- Disconnect both inclinometers and reconnect the bypass connections. For instructions on the disconnection of an inclinometer and the reconnection of bypass connections, refer to p. 45 of the *Safety Devices* section.
- 13- Proceed with the dismantling of the bearing bridge structure. For instructions on how to dismantle a bearing bridge structure, refer to p. 54 of the *Bridges* section.

Storage of the motorized units

- 14- Lower both motorized units to base level. Remove and store the jacks used for the base outriggers on each motorized unit.
- 15- Close all base outriggers on both motorized units.
- 16- If any of the units is to be stored for any significant length of time, refer to p. 110 of the *Transport, Storage and Maintenance* section for instructions on how to properly store a P Series motorized unit.

Dismantling a non standard single unit configuration with mast ties

E

The following dismantling steps must be used to dismantle a **non standard single unit configuration with mast ties** installed following method of installation “E”. Refer to p. 30 of this section for more information about method of installation “E”. For instructions on the dismantling of a standard single unit configuration with mast ties, refer to method of dismantling “C”, on p. 39 of this section.

Preparing the installation

- 1- Prepare the installation as described in the safety guidelines and preparation instructions for dismantling a P Series installation, on p. 36 of this section.
- 2- **Make sure that any additional equipment or accessory has been removed**, (front or rear extension, swivel bridge, 4- or 5-plank configuration, weather protection, monorail or hoist support structure). The setup must meet the conditions for a standard configuration **before the start of any dismantling operations**. For more information about a standard configuration, refer to p. 19 of this section.
- 3- Remove all planking, except in the area in front of the mast. Push in all outriggers where planking was removed and secure in place.
- 4- Raise the motorized unit to the top of the work.

Definition of a non standard configuration

A **non standard configuration**, referred to throughout this owner’s manual and related documentation, is an installation **requiring** the use of **angled or non-linear equipment**, such as a front/rear extension bridge, a swivel bridge, or a planking configuration wider than three planks, **or an accessory** such as weather protection, a monorail or a hoist support structure with a hoist. Freestanding is not allowed for a non standard configuration. It is **mandatory to pre-install all required mast sections and tie levels to reach the total mast height specified in the layout plan** when using a non standard configuration. It is mandatory to refer to the *Load Capacities* section on p. 73 for the number of bridges allowed in a non standard single unit or twin units installation.



CAUTION

Before starting to dismantle any **non standard configuration**, make sure to **remove any installed additional equipment or accessory** for the setup to meet the conditions for a standard, linear configuration.

Motorized Unit

Dismantling an Installation

E Dismantling a non standard single unit configuration with mast ties

Removing mast sections and tie levels

- 5- Lower the motorized unit to base level, removing mast sections and mast ties on the way down, **leaving the last two tie levels in place**. Refer to p. 63 of the *Mast and Mast Ties* section for instructions on how to remove and transport mast sections. Refer to p. 67 of the *Mast and Mast Ties* section for instructions on how to remove mast ties.

Mast sections loaded on the platform must be stored horizontally and distributed equally on either side of the mast to ensure good balance.

Make sure to avoid overloading the platform. On higher installations, it may be required to use a crane to remove mast sections from the platform to avoid any overloads. Refer to the *Load Capacities* section on p. 73 for more information about loads allowed on an installation.

Removing the last two tie levels

- 6- **With the last two tie levels still in place**, make sure that **all base outriggers are opened at a 30-degree angle**. If base outriggers must be parallel to the face of the work, make sure that the **lowest (last) tie level is no higher than 10' (3 m) above base level**. If necessary, install a tie level at 10' (3 m) above base level.

If base outriggers are required to be completely closed during dismantling or if the base of the motorized unit was replaced by a mast base plate, it is **mandatory** to refer to and comply with the dismantling instructions for an installation with a mast base plate, on p. 102 of the *Accessories* section.

- 7- Once the stability of the motorized unit has been secured, remove the last two tie levels and the remaining mast sections.

Removing planking, outriggers and guardrails

- 8- Once at base level, remove all loads from the platform and make all workers step down.
9- Remove all remaining planking, push in all outriggers and secure in place. Remove and store all guardrails. For instructions on the removal and storage of guardrails, refer to p. 109 of the *Transport, Storage and Maintenance* section.

Removing access stairs, cantilever bridges and access bridge

- 10- If required, remove the access stairs. Clean and store the access stairs components properly. For instructions on the storage of the access stairs, refer to p. 110 of the *Transport, Storage and Maintenance* section.
11- Remove all installed cantilever bridges, leaving no more than one 30" (76 cm) bridge installed at each end of the motorized unit. Make sure to remove bridges alternately on one side of the mast, then on the other, to ensure stability. Clean and store bridges properly. For instructions on the storage of a bridge, refer to p. 109 of the *Transport, Storage and Maintenance* section.
12- If required, remove the access bridge. Clean and store the access bridge components properly. For instructions on the storage of the access bridge, refer to p. 110 of the *Transport, Storage and Maintenance* section.

Storage of the motorized unit

- 13- Remove and store the jacks used for the base outriggers. Close all base outriggers.
14- If the unit is to be stored for any significant length of time, refer to p. 110 of the *Transport, Storage and Maintenance* section for instructions on how to properly store a P Series motorized unit.

Motorized Unit

Dismantling an Installation

Dismantling a non standard twin units configuration with mast ties



The following dismantling steps must be used to dismantle a **non standard twin units configuration with mast ties** installed following method of installation "F". Refer to p. 32 of this section for more information about method of installation "F". For instructions on the dismantling of a standard twin units configuration with mast ties, refer to method of dismantling "D", on p. 40 of this section.

Preparing the installation

- 1- Prepare the installation as described in the safety guidelines and preparation instructions for dismantling a P Series installation, on p. 36 of this section.
- 2- **Make sure that any additional equipment or accessory has been removed**, (front or rear extension, swivel bridge, 4- or 5-plank configuration, weather protection, monorail or hoist support structure). The setup must meet the conditions for a standard configuration **before the start of any dismantling operations**. For more information about a standard configuration, refer to p. 19 of this section.
- 3- Remove all planking, except in the area in front of the mast. Push in all outriggers where planking was removed and secure in place.
- 4- Raise the motorized units to the top of the work.

Removing mast sections and tie levels

- 5- Lower the twin motorized units linked by a bearing bridge, removing mast sections and mast ties on the way down, **leaving the last two tie levels in place on each mast**. To make sure that the installation remains stable, remove mast sections alternately – one on one motorized unit, then one on the other. Refer to p. 63 of the *Mast and Mast Ties* section for instructions on how to remove and transport mast sections. Refer to p. 67 of the *Mast and Mast Ties* section for instructions on how to remove mast ties.

Mast sections loaded on the platform must be stored horizontally and distributed equally on either side of each mast to ensure good balance.

Make sure to avoid overloading the platform. On higher installations, it may be required to use a crane to remove mast sections from the platform to avoid any overloads. Refer to the *Load Capacities* section on p. 73 for more information about loads allowed on an installation.



CAUTION

Before starting to dismantle any **non standard configuration**, make sure to remove any installed additional equipment or accessory for the setup to meet the conditions for a standard, linear configuration.

Definition of a non standard configuration

A **non standard configuration**, referred to throughout this owner's manual and related documentation, is an installation **requiring** the use of **angled or non-linear equipment**, such as a front/rear extension bridge, a swivel bridge, or a planking configuration wider than three planks, **or an accessory** such as weather protection, a monorail or a hoist support structure with a hoist. Freestanding is not allowed for a non standard configuration. It is **mandatory to pre-install all required mast sections and tie levels to reach the total mast height specified in the layout plan** when using a non standard configuration. It is mandatory to refer to the *Load Capacities* section on p. 73 for the number of bridges allowed in a non standard single unit or twin units installation.

Removing the last two tie levels

- 6- **With the last two tie levels still in place**, make sure that **all base outriggers are opened at a 30-degree angle**. If base outriggers must be parallel to the face of the work, make sure that the **lowest (last) tie level is no higher than 10' (3 m) above base level**. If necessary, install a tie level at 10' (3 m) above base level.

If base outriggers are required to be completely closed or if the base of one or both motorized units was replaced by a mast base plate, it is **mandatory** to refer to and comply with the dismantling instructions for an installation with a mast base plate, on p. 102 of the *Accessories* section.

Motorized Unit

Dismantling an Installation

F

Dismantling a non standard twin units configuration with mast ties

Removing the last two tie levels (cont'd)

- 7- Once the stability of both motorized units has been secured, remove the last two tie levels on each mast and the remaining mast sections.

Removing planking, outriggers and guardrails

- 8- Lower the twin motorized units linked by a bearing bridge until the units are two rungs (20" or 50 cm) above base level.
- 9- Once the units are two rungs above base level, remove all loads from the platform and make workers step down.
- 10- Remove all remaining planking, push in all outriggers and secure in place. Remove and store all guardrails. For instructions on the removal and storage of guardrails, refer to p. 109 of the *Transport, Storage and Maintenance* section.

Removing access stairs, cantilever bridges and access bridge

- 11- If required, remove the access stairs. Clean and store the access stairs components properly. For instructions on the storage of the access stairs, refer to p. 110 of the *Transport, Storage and Maintenance* section.
- 12- First remove all installed cantilever bridges, leaving no more than one 30" (76 cm) bridge installed at each end of the twin units installation. Make sure to remove bridges alternately on one side of the mast, then on the other, to ensure stability. Clean and store bridges properly. For instructions on the storage of a bridge, refer to p. 109 of the *Transport, Storage and Maintenance* section.
- 13- If required, remove the access bridge. Clean and store the access bridge components properly. For instructions on the storage of the access bridge, refer to p. 110 of the *Transport, Storage and Maintenance* section.

Removing the bearing bridge structure

- 14- Disconnect both inclinometers and reconnect the bypass connections. For instructions on the disconnection of an inclinometer and the reconnection of bypass connections, refer to p. 45 of the *Safety Devices* section.
- 15- Proceed with the dismantling of the bearing bridge structure. For instructions on how to dismantle a bearing bridge structure, refer to p. 54 of the *Bridges* section.

Storage of the motorized units

- 16- Lower both motorized units to base level. Remove and store the jacks used for the base outriggers on each motorized unit.
- 17- Close all base outriggers on both motorized units.
- 18- If any of the units is to be stored for any significant length of time, refer to p. 110 of the *Transport, Storage and Maintenance* section for instructions on how to properly store a P Series motorized unit.

Safety Devices

Inclinometer (Leveling Control Device)

Used only in twin units configurations, the inclinometer is located on the bearing bridge adapter (fig. 2.3 and fig. 2.4) and must **absolutely** be linked to the electrical system of the motorized unit through its main electrical power supply box (fig. 2.2).

Each inclinometer of a twin units configuration will detect any ± 2 -degree slope of the structure and stop the motorized unit that is higher (when rising) or lower (when lowering) until the structure is level again. For more information on the installation and the use of a bearing bridge adapter, see p. 53 of the *Bridges* section.

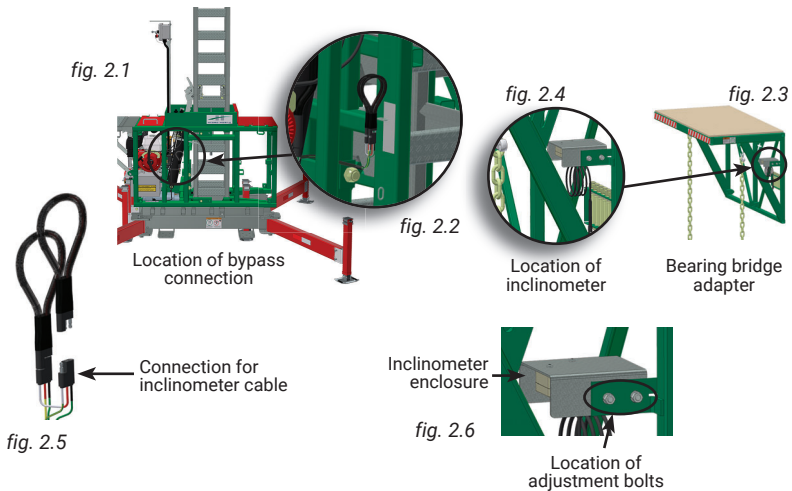

Connecting and resetting the inclinometers

- 1- Make sure the bearing bridge structure is level.
- 2- Locate the bypass connection (loop) on the structure of the motorized unit (fig. 2.2).
- 3- Disconnect the bypass connection and plug in the inclinometer connection cable (fig. 2.5).
- 4- Place a torpedo level on top of the inclinometer enclosure. Verify the level of the inclinometer.
- 5- Loosen one of the adjustment bolts (fig. 2.6) and raise or lower the enclosure until the inclinometer is set at a 0° level. Tighten the bolt.
- 6- Repeat steps 2 to 4 for the inclinometer at the other end of the bearing bridge structure.
- 7- If any of the inclinometers cannot be adjusted to a 0° level, the motorized units must be put out of service until the installation has been inspected and the issue has been corrected by a qualified person. For the definition of a qualified person, refer to p. 7 of the *Performance and Safety Rules* section.
- 8- Make sure to test both inclinometers before operating the motorized unit.

**CAUTION**

When raising or lowering motorized units linked by a bearing bridge, any bridge slope must not to exceed a maximum of 2° or $1'' / 24''$ (2,5 cm / 61 cm).

Safety Devices

Inclinometer (Leveling Control Device)

Testing the inclinometers

- 1- Make sure the bearing bridge structure is level and that both inclinometers are connected properly.
- 2- Raise one end of the bearing bridge structure. If the inclinometers are working properly, the higher unit stops moving when a slope of the structure is detected and the lower motorized unit cannot be lowered. Bring the structure back to level, following the instructions further on.
- 3- Repeat step 2 at the other end of the bearing bridge structure. Bring the structure back to level.
- 4- Raise the bearing bridge structure until it is at least 10' (3 m) above base level. Make sure the bearing bridge structure is level.
- 5- Lower one end of the bearing bridge structure. If the inclinometers are working properly, the lower unit stops moving when a slope of the structure is detected and the higher motorized unit cannot be raised. Bring the structure back to level.
- 6- Repeat step 5 at the other end of the bearing bridge structure. Bring the structure back to level.
- 7- If any of the inclinometers is not working properly, the motorized units must be put out of service until they have been inspected and repaired by a qualified person. For the definition of a qualified person, refer to p. 7 of the *Performance and Safety Rules* section.

Bringing the structure back to level

- 1- When the motorized units are moving, if one of the inclinometers detects a slope of ± 2 degrees of the bearing bridge structure (fig. 2.7), the power supply of the solenoid valves is shut off. Both motorized units stop moving but the engines are still running.
- 2- To bring the bearing bridge structure back to level and resume operation, bypass the inclinometer signal **on the lowest motorized unit of the installation** by pushing in and holding the inclinometer bypass button on the joystick control box (fig. 2.8) and raising the motorized unit until the setup is level again. **Always bypass the signal on the lowest unit on the installation** and raise that unit, whether the platform is being raised or lowered.
- 3- Make sure that the bearing bridge structure is level before resuming operation. Repeat step 2, if necessary.

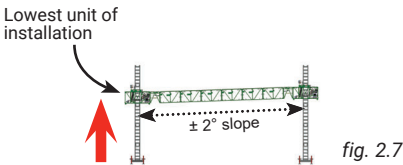

Inclinometer signal must be bypassed on the **lowest motorized unit** and that unit must be raised – whether the platform is being raised or lowered

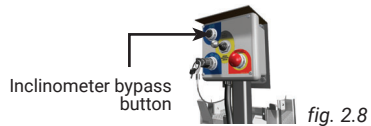

CAUTION

Always bypass the signal on the lowest motorized unit of the installation and raise that unit, whether the platform is being raised or lowered.



CAUTION

Daily verification and testing of all the inclinometers are mandatory before operating the motorized units.

Safety Devices

Safety Hooks System

Activation of the safety hooks system

In the event of an activation of the safety hooks system, the qualified operator must contact the competent person. For the definition of a qualified operator or a competent person, refer to p. 7 of the *Performance and Safety Rules* section.

All precautions must be immediately taken to ensure the safe return of all workers to the nearest safe evacuation point according to the evacuation plan (see step 16, p. 8 of the *Performance and Safety Rules* section). **The motorized unit must be immediately put out of service.**

The following steps must be performed by a qualified technician. For the definition of a qualified technician, refer to p. 7 of the *Performance and Safety Rules* section. Seek advice from the distributor/service center or the Hydro Mobile technical team, if required.

- 1- Make sure the safety hooks system is properly engaged (fig. 2.10) and that the motorized unit is stable and secure.
- 2- Determine what caused the activation of the safety hooks system.
- 3- Remove as much load from the motorized unit and the bridges as possible.
- 4- Perform a thorough inspection of the entire installation from base level to the top of the work, including structures, mast ties, anchoring system for any damages possibly caused by the incident.
- 5- Take the necessary actions to have the motorized unit repaired properly, according to Hydro Mobile standards. It is **mandatory** to visually inspect the safety hooks and replace the hook that was activated. Any **triggered** safety hook **cannot be used a second time and must be replaced immediately** before operating the motorized unit. It is **mandatory** to also replace the bolt and nut of the safety hook.
- 6- Once all the mandatory corrective actions described in the previous steps have been carried out, make sure that the cylinder hook and the secondary hook are properly engaged on a mast rung (fig. 2.12 and fig. 2.13) and **carefully lower** the motorized unit to base level.
- 7- In all cases, the motorized unit must be thoroughly inspected and all the necessary repairs must be made according to Hydro Mobile's recommendations before resuming normal operation of the motorized unit.

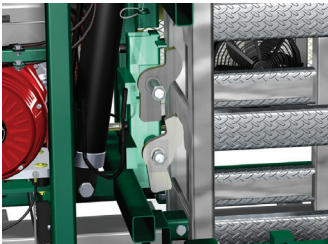

Safety hooks in normal working position

fig. 2.9

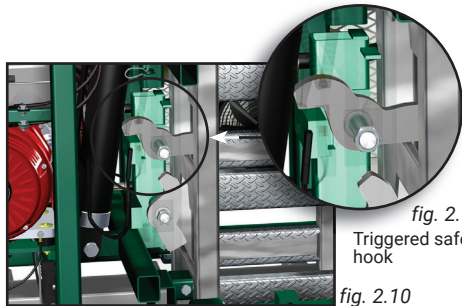

fig. 2.11
Triggered safety hook

fig. 2.10

Safety hooks in emergency activation position



fig. 2.12

Correct



fig. 2.13

Incorrect

Safety Devices

Fall Protection

The use of fall protection equipment is **mandatory** for all workers on a P Series motorized unit setup whenever a fall hazard is present.

It is recommended to use a combination of full body harness and a shock-absorbing lanyard. It is mandatory to use certified fall protection equipment that is clean and in good working condition. Fall protection equipment must be inspected before each use and be replaced if found to be defective. Refer to the manufacturer's recommendations for more information about the use and care of the selected equipment. Refer also to local regulations for more information about fall protection equipment requirements.

When erecting or dismantling

The use of appropriate fall protection equipment is **mandatory** for erectors/dismantlers during the installation and removal of mast sections and tie levels. Failure to use fall protection equipment can expose the user to serious injury or death. For the definition of a qualified erector/dismantler, refer to p. 7 of the *Performance and Safety Rules* section.

When climbing up or down the mast

The use of appropriate fall protection equipment is **mandatory** when using the mast for climbing up or down at heights between 30' (9.1 m) and 69' (21 m). Failure to use fall protection equipment can expose the user to serious injury or death. It is not recommended to climb up the mast to reach work areas at heights over 69' (21 m) because of the time and effort required to reach such heights. The use of alternate equipment compliant with local regulations, such as a rapid mast climber, a transport platform system, or a conventional scaffold stair system will prove to be more efficient. Refer to local regulations for more information.

When moving planks

The use of appropriate fall protection equipment is **mandatory** when moving planks – for example, when moving planks away from in front of the mast to pass a tie level or when modifying the plank configuration. Failure to use fall protection equipment can expose the user to serious injury or death.

Securing fall protection equipment to a self-retracting lifeline

- 1- Attach a rope to a self-retracting lifeline hook for easy retrieval from base level.
- 2- Using the designated tie points (fig. 2.15) on the motorized unit, secure the fall protection equipment. Tie points are designed to resist to a maximum arrest force of 5000 lb (2268 kg) and can be used by workers to tie themselves to the unit (not more than one worker per chain link).
- 3- Attach the body harness to the self-retracting lifeline before climbing or descending the mast.

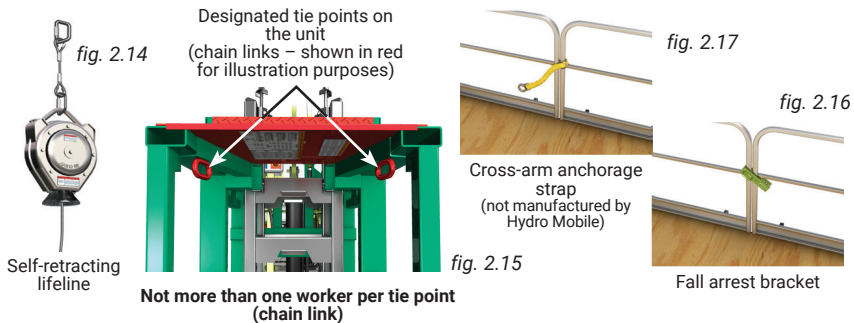

Securing fall protection equipment to a tie point

- 1- Using the designated tie points (fig. 2.15) on the motorized unit, an optional fall arrest bracket installed on two guardrails (fig. 2.17) or a cross-arm anchorage strap tied to two guardrails (fig. 2.16), secure the fall protection equipment.
- 2- Tie points are designed to resist to a maximum arrest force of 5000 lb (2268 kg) and can be used by workers to tie themselves to the unit (not more than one worker per tie point). Only 30" (76 cm), 33" (84 cm) or 60" (1,6 m) **standard guardrails** can be used as tie points; it is prohibited to use a twin mast adapter guardrail, a swivel bridge guardrail, a door guardrail, a movable guardrail, a plank-end guardrail or a face guardrail bracket as a tie point. It is mandatory to make sure that the guardrail used as a tie point is properly fastened.

Safety Devices

Emergency Descent Control Device

In the event of an engine failure, a shortage of gasoline or a power outage, it is recommended to use the emergency descent control device to bring the workers and the motorized unit safely to the **nearest safe evacuation point** according to the evacuation plan (see step 16, p. 8 of the *Performance and Safety Rules* section). The emergency descent control device (120 V in North America; 240 V in Europe) is standard only on specific P Series motorized units. It is important to note that the emergency descent control device **must not be used** if the failure is due to a malfunction of the cylinder, a malfunction of one or both hooks, or a leak in the hydraulic system.



CAUTION

Emergency descent control devices are designed for emergencies only. These devices must not be used to operate the motorized unit **under normal conditions**.

Emergency descent procedure

- 1- Before initiating the descent, make sure that the motorized unit and plank outriggers clear mast ties, the building, balconies, etc.
- 2- Unlock the lowering cam on both the cylinder hook and the secondary hook (fig. 2.19).
- 3- Open the engine access panel. Locate the power cord for the emergency descent motor. Connect the power cord of the emergency descent motor into an appropriate, reliable power source, using an extension cord, if necessary. The emergency motor will start immediately once it is plugged into the power source.

If the motorized unit is equipped with a **power pack bridge**, perform the following actions **on the power pack bridge, not on the motorized unit**.

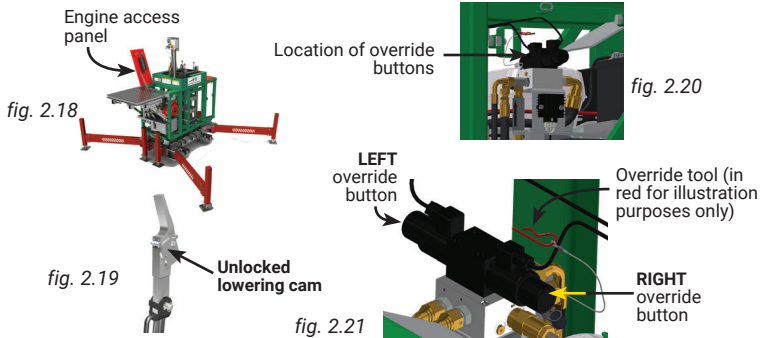

- 4- Locate the override buttons on top of the hydraulic block (fig. 2.20). Since the control lever cannot be used to control the motorized unit when using the emergency motor, the override buttons must be used to control the movement of the motorized unit.
- 5- Perform the necessary steps to **lower or raise the motorized unit to the nearest safe evacuation point**, using the override buttons instead of the control lever, where the **LEFT** button will act as bringing the control lever **DOWN** (extend the cylinder), while the **RIGHT** button will act as bringing the control lever **UP** (retract the cylinder). Refer to p. 59 and p. 61 of the *Power Pack and Controls* section for instructions on raising and lowering the motorized unit.

Action on override button	Correspondence on control lever
Press and hold LEFT override button	Lower the control lever
Press and hold RIGHT override button	Raise the control lever

- 6- If the nearest safe evacuation point is at base level, monitor the last 10' (or 3 m) of descent to ensure the proper seating of the access stairs and the access bridge, if necessary.



CAUTION

It is important to note that the emergency descent control device **must not be used** if the failure is due to a malfunction of the cylinder, a malfunction of one or both hooks, or a leak in the hydraulic system.

Bridges Bridge Types

5' (1,5 m) bridge

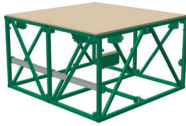

fig. 3.1

Dimensions	60" x 62 1/4" x 35 13/16" (152 cm x 158 cm x 91 cm)
Weight	390 lb (177 kg)
Guardrail	1x 60" (152 cm) – 58 lb (26,3 kg)
Outrigger	1x 2 1/2" x 1 1/2" x 1/8" x 63" long (6,4 cm x 3,8 cm x 0,3 cm x 160 cm)
Bolt and nut set	6x 5/8" x 5 1/2" long (GR8 UNC)

30" (76 cm) bridge



fig. 3.2

Dimensions	30 1/2" x 62 1/4" x 35 13/16" (77,4 cm x 158 cm x 91 cm)
Weight	290 lb (132 kg)
Guardrail	1x 30" (76 cm) – 40 lb (18,1 kg)
Outrigger	1x 2 1/2" x 1 1/2" x 1/8" x 63" long (6,4 cm x 3,8 cm x 0,3 cm x 160 cm)
Bolt and nut set	6x 5/8" x 5 1/2" long (GR8 UNC)

10' (3 m) bridge

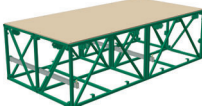

fig. 3.3

Dimensions	120" x 62 1/4" x 35 13/16" (305 cm x 158 cm x 91 cm)
Weight	720 lb (327 kg)
Guardrail	2x 60" (152 cm) – 58 lb (26,3 kg) (not included)
Outrigger	2x 2 1/2" x 1 1/2" x 1/8" x 63" long (6,4 cm x 3,8 cm x 0,3 cm x 160 cm)
Bolt and nut set	6x 5/8" x 5 1/2" long (GR8 UNC)

Bearing bridge adapter



fig. 3.4

Dimensions	30 3/8" x 62 1/4" x 35 13/16" (77,2 cm x 158 cm x 91 cm)
Weight	230 lb (104 kg) (without guardrail)
Guardrail	1x movable guardrail – 65 lb (29,5 kg) (not included)
Accessories	Inclinometer and safety chains
Bolt and nut set	6x 5/8" x 5 1/2" long (GR8 UNC)

Swivel bridge



fig. 3.5

Dimensions	67 7/8" x 62 1/4" x 39 1/2" (172,4 cm x 158 cm x 100,3 cm)
Weight	800 lb (363 kg)
Guardrail	1x swivel bridge guardrail – 120 lb (54,4kg) (not included)
Outriggers	2x 2 1/2" x 1 1/2" x 1/8" x 63" long (6,4 cm x 3,8 cm x 0,3 cm x 160 cm)
Bolt and nut set	6x 5/8" x 5 1/2" long (GR8 UNC)
Fillers	2x

Bridge for restricted space



fig. 3.6

Dimensions	21" x 62 1/4" x 35" (53 cm x 158 cm x 89 cm)
Weight	196 lb (89 kg)
Outriggers	4x 32" (81 cm) outriggers 2x 20" (51 cm) outriggers
Bolt and nut set	6x 5/8" x 5 1/2" long (GR8 UNC)

Multi-purpose bridge



fig. 3.7

Dimensions	33 1/4" x 62" x 35 13/16" (84,5 cm x 158 cm x 91 cm)
Weight (includes weight of guardrail)	330 lb (170 kg)
Guardrail	1x 33" (81 cm) – 41 lb (19 kg)
Outrigger	1x 2 1/2" x 1 1/2" x 1/8" x 63" long (6,4 cm x 3,8 cm x 0,3 cm x 160 cm)
Bolt and nut sets	4x 5/8" x 4 1/2" long (GR8) 6x 5/8" x 5 1/2" long (GR8)

Bridges

Standard bridge

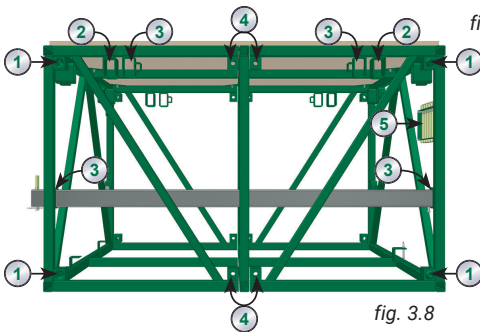

fig. 3.8

fig. 3.9



Tapered bushing

fig. 3.10

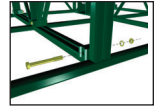

Bolt for assembly

- ① Tapered bushing
- ② Guardrail pocket
- ③ Top or bottom outrigger pocket
- ④ Pairs of bushings in middle of bridge
- ⑤ Bolt assemblies (4)

Installation of a 5' (1,5 m) or 30" (76 cm) bridge on the motorized unit

- 1- Align the bridge with the motorized unit using the tapered bushings ("1" in fig. 3.8).
- 2- Bolt the bridge to the motorized unit using **eight** bolt assemblies: one 5/8" x 5 1/2" (GR8) hex bolt, one 5/8" (GR8) lock washer and one 5/8" (GR8) nut in each of the four corner tapered bushings and in **each** of the pairs of bushings in the middle of the bridge (using **both top and bottom bushings on each side** – left and right, fig. 3.11). Tighten all bolt assemblies with a torque of 120 lb-ft (163 N-m).
- 3- Set up bridges alternately on each side of the mast in such a sequence as to warrant the balance of the structure.

Assembly of two 5' (1,5 m) or 30" (76 cm) bridges together

- 1- Align both bridges using the tapered bushings ("1" in fig. 3.8).
- 2- Assemble both bridges together using **six** bolt assemblies: one 5/8" x 5 1/2" (GR8) hex bolt, one 5/8" (GR8) lock washer and one 5/8" (GR8) nut in each of the four corner tapered bushings and in **one** of the pairs of bushings in the middle of the bridge (**using top and bottom bushings on either side** – left or right, fig. 3.12). Tighten all bolt assemblies with a torque of 120 lb-ft (163 N-m).
- 3- Set up bridges alternately on each side of the mast in such a sequence as to warrant the balance of the structure.

Installation of a multi-purpose bridge on the motorized unit or another bridge

- 1- Align the tapered bushings ("1" in fig. 3.8) of the multi-purpose bridge with the motorized unit or the bridge.
- 2- Bolt the multi-purpose bridge to the motorized unit or the bridge using a 5/8" x 4 1/2" (GR8) bolt assembly in each of the four corner tapered bushings. Tighten all bolt assemblies with a torque of 120 lb-ft (163 N-m).
- 3- Set up multi-purpose bridges alternately on each side of the mast in such a sequence as to warrant the balance of the structure.

Assembly of two multi-purpose bridges together

- 1- Align both multi-purpose bridges using the tapered bushings ("1" in fig. 3.8).
- 2- Assemble both bridges together using **six** bolt assemblies: one 5/8" x 5 1/2" (GR8) hex bolt, one 5/8" (GR8) lock washer and one 5/8" (GR8) nut in each of the four corner tapered bushings and in **one** of the pairs of bushings in the middle of the bridge (using top and bottom bushings on either side – left or right, fig. 3.12). Tighten all bolt assemblies with a torque of 120 lb-ft (163 N-m).
- 3- Set up multi-purpose bridges alternately on each side of the mast in such a sequence as to warrant the balance of the structure.

fig. 3.11

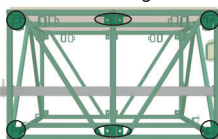
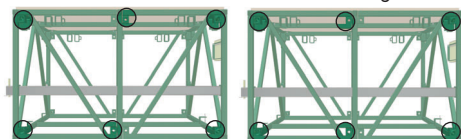

fig. 3.12



Bridges

Cantilever Bridge

Installation

- 1- Raise the motorized unit by 2 rungs (20" or 50 cm) to facilitate the installation of bridges.
- 2- Bolt a bridge assembly to the motorized unit on one side of the mast. It is important to note that bridge support installation brackets cannot be used to support a bridge that is installed directly on the motorized unit. If the bridge installed on the motorized unit is a 30" (76 cm) bridge, make sure that the **upper corner of the diagonal brace is pointing outwards**, as shown in fig. 3.13.
- 3- Repeat step 2 to bolt a second bridge assembly at the other end of the unit. Refer to p. 51 of this section for instructions on the installation of a bridge.

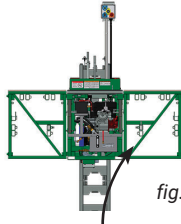

fig. 3.13

Upper corner of the diagonal brace must point outwards

- 4- Install as many additional bridges as required and allowed.
It is important to install each bridge alternately on one side, then on the other side of the mast, to avoid throwing the structure out of balance. The number of bridges must be equal on both sides of the mast for a single unit installation. For more information about the use of bridge installation support brackets, refer to p. 89 of the *Accessories* section. Refer to the *Load Capacities* section on p. 73 for information about the number of bridges allowed in a cantilever bridge configuration.

Bearing Bridge

(requires the use of two motorized units and two bearing bridge adapters – sold separately)

Safety guidelines

- 1- In a twin units configuration, it is mandatory to install any additional cantilever bridge **after** the bearing bridge structure has been installed to avoid throwing the structure off balance.
- 2- It is **mandatory** that two qualified users/operators handle all rise and descent operations and coordinate the motion of the two motorized units linked by a bearing bridge to ensure that the structure slope does not exceed 2° or 1" / 24" (2,5 cm / 61 cm). For the definition of a qualified user/operator, refer to p. 7 of the *Performance and Safety Rules* section.
- 3- It is also important to make sure that all safety chains (two at each end) are properly hooked at all times (see step 3 of the installation instructions beginning on p. 53).
- 4- Daily verification and testing of all the inclinometers are **mandatory before** operating the motorized units.

Assembly of a bearing bridge structure

- 1- Choose a clear, level surface close to the work area where the bridges can be temporarily set down to assemble the bearing bridge structure. To facilitate assembly, set down wood cribbing or mast sections laid horizontally before lowering the bridges in place.



NOTICE

To ensure safe and proper operation, Hydro Mobile recommends that **two persons** be on hand to perform maneuvers for **each motorized unit in a setup** and that **at least one of those two persons is a qualified user/operator** for a P Series motorized unit and its accessories.

Bridges

Bearing Bridge

(requires the use of two motorized units and two bearing bridge adapters – sold separately)

Assembly of a bearing bridge structure (cont'd)

- 2- Using a rough terrain forklift or a crane, lift and lower a bridge on top of the wood cribbing or the laid down mast sections.
- 3- Lift another bridge and align it carefully with the bridge it must be attached to.
- 4- Assemble the two bridges together. For instructions on the installation of a bridge on another bridge, refer to p. 51 of this section.
- 5- Complete the assembly of the bearing bridge structure using as many bridges as is required and allowed. Refer to p. 73 of the *Load Capacities* section for information on the number of bridges allowed in a bearing bridge configuration.
- 6- Install a bearing bridge adapter at each end of the bearing bridge structure.

Installation of a bearing bridge structure

A P Series bearing bridge installation can be installed at an offset angle not exceeding 5 degrees. It is mandatory to make sure that there is an **overlap of at least 6" (15 cm) at both ends of the bearing bridge structure** and that both ends are properly supported, as shown in fig. 3.15.

- 1- Make sure the twin motorized units are positioned properly.
- 2- Using a rough terrain forklift, a crane or any other appropriate lifting device, lift the bearing bridge assembly from the ground and lower it down onto the two motorized units making sure the overlap is between 6" and 12" (15 and 30 cm) at each end.
- 3- Install one bearing bridge safety chain by making a loop near the top end of the diagonal brace on the 30" (76 cm) bridge. Insert the chain into the safety notch, making sure the slack does not exceed one link when pulling it tightly towards the safety notch (fig. 3.14). Secure the end of the chain to the rest of the chain with a shackle. Perform this step for each safety chain at both ends of the bearing bridge structure (four in total).

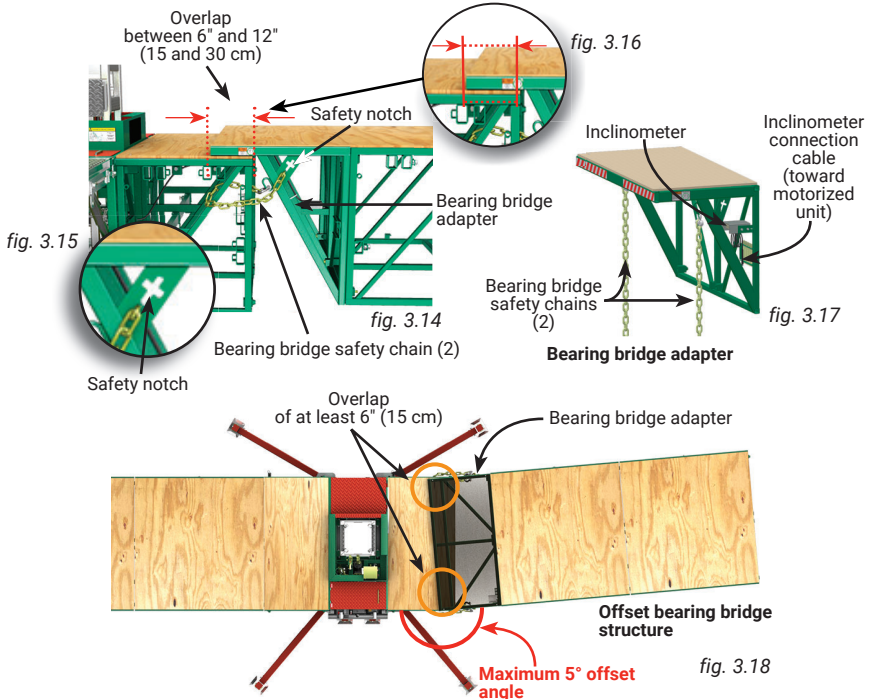

Bridges

Bearing Bridge

(requires the use of two motorized units and two bearing bridge adapters – sold separately)

Dismantling a bearing bridge structure

SAFETY comes first. It is essential that all dismantling operations of a bearing bridge be carried out with the same care and precaution taken during the installation. It is mandatory to refer to the safety guidelines and to select the dismantling method appropriate to the installation, starting on p. 36 of the *Motorized Unit* section. The following dismantling steps are for the bearing bridge structure only.

- 1- Make sure the motorized units are two rungs (20" or 50 cm) above base level.
- 2- Make sure both inclinometers have been disconnected and that all bypass connections have been reconnected.
- 3- Make sure that all cantilever bridges have been removed.
- 4- Completely unload the work platform and make workers step down off the structure.
- 5- Unhook the bearing bridge safety chains (four in total).
- 6- Using a rough terrain forklift or a crane, slightly raise the bearing bridge structure and lower it on a proper bearing surface for disassembly.
- 7- Store all bearing bridge components properly. For instructions on the storage of a bridge, refer to p. 109 of the *Transport, Storage and Maintenance* section.

Front/Rear Extension Bridge (optional)

The extension bridge (used on the front or on the back of a motorized unit setup) is assembled using a regular bridge, two outriggers and three forward extension plate assemblies. Refer to p. 78 of the *Load Capacities* section for the load capacities and the configurations allowed.

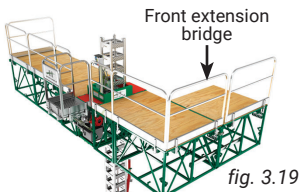

fig. 3.19

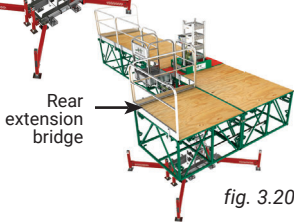

fig. 3.20

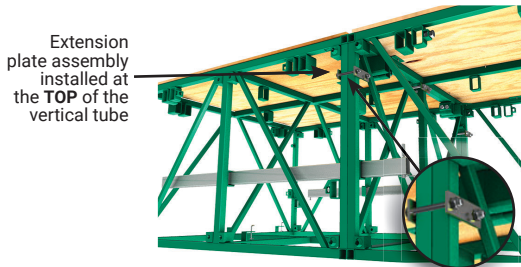

fig. 3.21

Connection of two new generation bridges

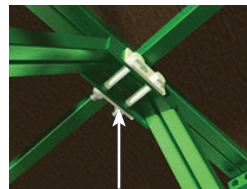

fig. 3.23

Connection of previous generation bridge (right) with new generation bridge (left)

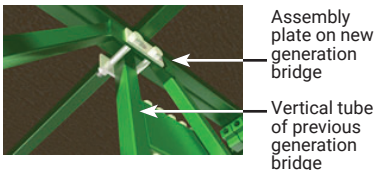

fig. 3.22

Installation

- 1- Remove the plank stop pins from two outriggers and slide the outriggers in the bottom outrigger pockets of a bridge assembly already installed, leaving about 6" (15 cm) protruding from the bridge. Do not tighten the bolt assemblies.

Bridges

Front/Rear Extension Bridge
(optional)

Installation (cont'd)

- 2- Align the bridge that will be used as an extension with the installed bridge and slide the protruding ends of the two outriggers from the bridge assembly in the bottom outrigger pockets of the rear or front extension bridge. Insert a plank stop pin in each outrigger.
- 3- Install the first two forward extension plate assemblies at the **TOP** of each of the two vertical tubes at each end of the bridge assembly (fig. 3.21, p. 54). If using only previous generation bridges, install the third extension plate assembly on the middle vertical tube of the bridge, secure the bolt assemblies and proceed to step 5.
- 4- If using at least one new generation bridge in the installation, install the third forward extension plate assembly at the **TOP** in the middle of the bridge structure by positioning the plates so the holes align with the holes on the plate in the middle of the bridge structure (fig. 3.23, p. 54). Secure with bolt assemblies.
- 5- Tighten all bolts on the outrigger pockets and on the extension plates with a torque of 30 lb-ft (41 N-m).
- 6- Install the appropriate guardrails on the back or forward extension bridge.
- 7- If required, install cross boxes and additional outriggers to plank the inside corner of the bridge used as an extension. For more information on the installation and use of cross boxes, refer to p. 91 of the *Accessories* section.

Bridge Deck Extension
(optional)

Bridge deck extensions can be attached to 30" (76 cm), 5' (1,5 m) and 10' (3 m) and multi-purpose bridges and are used to extend the width of the work area from 5' (1,5 m) to 7' 6" (2,3 m), increasing the circulation area available on the setup. Bridge deck extensions can only be used in standard configurations unless the deck extension is installed on the first bridge bolted to the motorized unit.

Bridge deck extensions **must only be used for the circulation of workers on the setup and must not be used as a storage area for material, tools, equipment or any other load.** The weight of each bridge deck extension installed must be taken into account when calculating the load capacity of a setup. Refer to the *Weight of Components* table on p. 14 of the *Motorized Unit* section.

Planking is not allowed when using bridge deck extensions in the **front of a setup.** It is important to note that using deck extensions will prevent the use of the top front outrigger pockets.

Installation

- 1- Remove the clevis pins and plank stop pins from two outriggers.
- 2- Slide the outriggers in the top outrigger pockets of the bridge and reinstall the clevis pins to prevent the outriggers from slipping out of the outrigger pockets.
- 3- Insert the bridge deck extension on the outriggers and push in the extension until it is snug against the bridge.
- 4- Install the plank stop pins and push in the outriggers until they are snug against the extension.
- 5- Tighten the bolt assemblies of the outrigger pockets both on the deck extension and the bridge to secure the outriggers in place.
- 6- Install the appropriate guardrails on the deck extension.

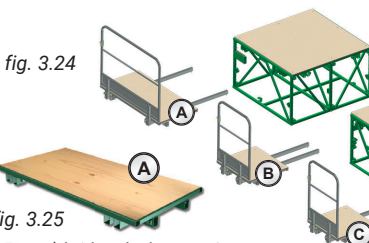

fig. 3.25
60" (152 cm) bridge deck extension
used on 5' (1,5 m) or 10' (3 m)
bridge

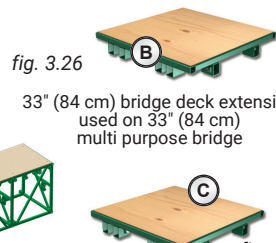

fig. 3.26
33" (84 cm) bridge deck extension
used on 33" (84 cm)
multi purpose bridge

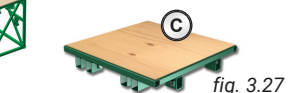
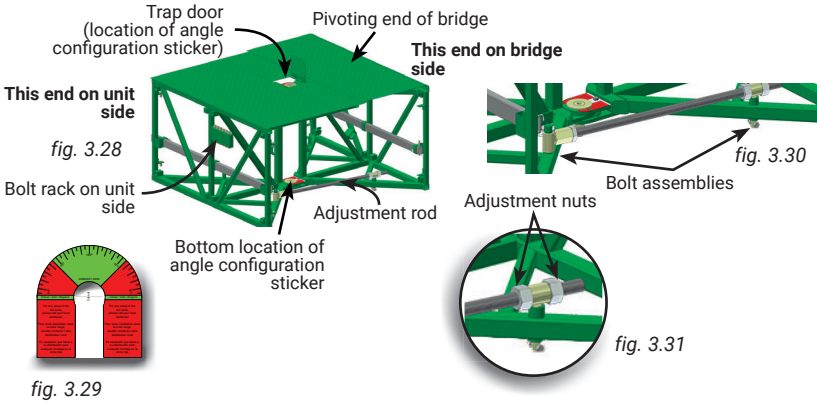

fig. 3.27
30" (76 cm) bridge deck extension
used on 30" (76 cm) bridge

Bridges

Swivel Bridge
(optional)

The swivel bridge allows creating front 0° to 45° configurations, as well as corner (90°) configurations and must be installed as a **cantilever bridge**. The swivel bridge **cannot be used on the bearing bridge side of a twin units configuration** nor to achieve rear configurations.



Installation

- 1- Make sure that there is a 30" (76 cm) bridge (not longer) already attached to the motorized unit.
- 2- Using the tapered bushings, align the swivel bridge with the 30" (76 cm) bridge. Make sure the bolt rack on the swivel bridge is toward the unit side.
- 3- Attach the swivel bridge to the 30" (76 cm) bridge and make sure all the bolt assemblies are tightened and secure. For instructions on the installation of a bridge, refer to the standard installation instructions, on p. 51 of this section.
- 4- Install as many additional bridges as required and allowed. Refer to p. 80 of the *Load Capacities* section for information on the number of bridges allowed in a swivel bridge configuration.

Angle adjustment

- 1- Make sure that the adjustment rod is installed toward the face of the wall. If required, remove the bolt assemblies at both ends of the adjustment rod and reinstall on the other side of the bridge (fig. 3.28).
- 2- Position the swivel bridge installation at the desired angle by turning the adjustment nut. Refer to the angle sticker located under the trap door on the bridge deck or on the pivot pin at the bottom of the bridge (fig. 3.28) to make sure the installation is at an appropriate angle. A P Series swivel bridge configuration may only be installed at an angle between 0 and 45 degrees or at exactly 90 degrees.

Installation of swivel bridge guardrails

Swivel bridge installations require the use of special guardrails, included with each swivel bridge. The installation of guardrails on a swivel bridge will depend on the angle of the configuration.

Since not all swivel bridge guardrails may be necessary for a given configuration, refer to specific instructions for the configuration for the assembly of the appropriate guardrails.

It is important to note that swivel bridge guardrails must not be used as a tie-off point.

	CAUTION
Swivel bridge guardrails must not be used as a tie-off point.	

Bridges

Swivel Bridge
(optional)

Installation of guardrails on front cantilever configurations (0 to 45° and 90°)

- 1- Lock the angle between parts "A" and "B" of the swivel bridge guardrail assembly at 0° using the angle stopper ("1", fig. 3.39).
- 2- Align the plates of the guardrail adapter ("2", fig. 3.39) with the **side** of the guardrail of the 30" (76 cm) bridge attached to the motorized unit and secure in place with bolts.
- 3- Align the hinge tubes located on part "A" of the swivel bridge guardrail assembly with the hinge tubes on the adapter on the 30" (71 cm) guardrail and secure in place with guardrail assembly pins ("4", fig. 3.39).
- 4- Insert the guardrail hinge pins ("5", fig. 3.39) on part "C" in the corresponding hinge tubes on part "B". Secure the assembly with hairpin cotter pins.
- 5- Install a 60" (152 cm) regular guardrail ("6", fig. 3.39) on the bridge attached to the swivel bridge.

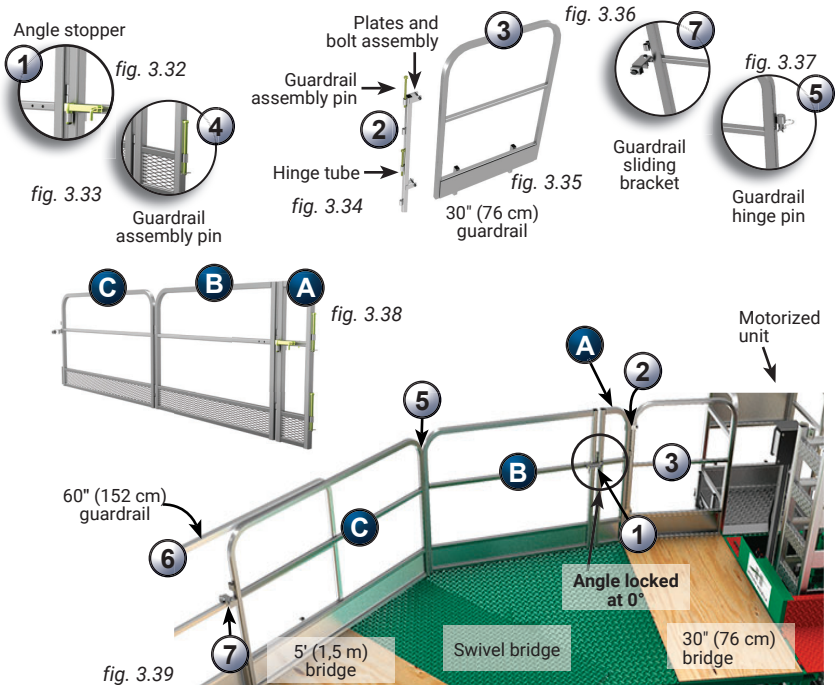

Front 45° cantilever configuration

- 6- Secure part "C" of the swivel bridge guardrail assembly to the inside of a 60" (152 cm) guardrail by tightening the bolt on the sliding bracket ("7", fig. 3.39).
- 7- Make sure all the necessary guardrails are in place and secure (see p. 83 of the *Accessories* section for more information about guardrails). In all cases where workers are exposed to fall hazards greater than specified by local regulations, the installation of guardrails or face guardrail supports is **mandatory**.

Power Pack and Operating Components

Startup preparation instructions

- 1- Pull the spring latch (fig. 4.2) and pull the control post completely out of its storage position.
- 2- Rotate the control post to 180° so that controls are facing the rear extension platform.
- 3- Pull the spring latch again and let the control post slide down until the spring latch is engaged and locks the control post in place.
- 4- If the motorized unit is brand-new or has been stored for a significant length of time, connect the battery.

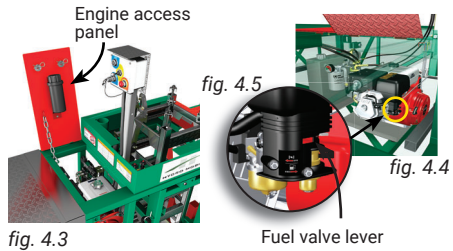
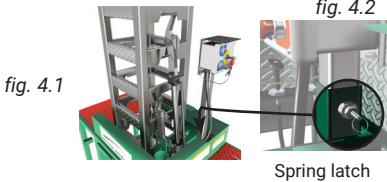

- 5- Perform every step in the daily inspection checklist. Refer to p. 112 of the *Transport, Storage and Maintenance* section for more information about the daily inspection.
- 6- Move the engine gasoline valve lever to the ON position.



CAUTION

Always make sure the rear extension platform is **lifted** before starting the engine and while engine is running. Remove the rear extension platform completely, if necessary. Make sure to maintain sufficient clearance from combustible material when engine is running.

Engine and motorized unit startup procedure

- 1- Make sure the rear extension platform is lifted before starting the engine.
- 2- **USING THE CHOKE:** Locate the choke cable (blue control cable, fig. 4.6). If the engine is cold, push in and hold the button to pull out the choke cable to the closed position. Adjust by rotating the knob, if necessary. If the engine is warm, leave the choke cable at the open position.
- 3- **USING THE THROTTLE:** Locate the throttle cable (yellow control cable, fig. 4.6). Push in and hold the button to pull out the throttle cable. Adjust by rotating the knob, if necessary.
- 4- Pull out the emergency stop button.
- 5- Turn and hold the ignition key at the START position (fig. 4.7) to start the engine (hold for a maximum of 10 seconds). Release the key as soon as the engine is running. Use the ignition key to shut down the engine.
- 6- Push in and hold the button, then slowly push down the choke cable all the way to the open position.
- 7- To adjust the engine speed, push in and hold the button, then push down the throttle cable to reach maximum RPM. Adjust by rotating the knob, if necessary.

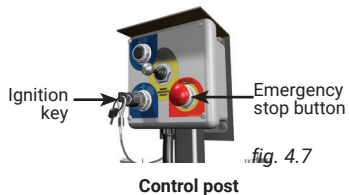
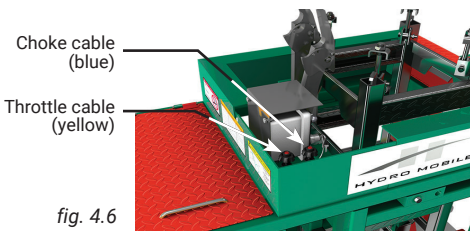

Power Pack and Operating Components

SAFETY comes first. The raising and lowering of the platform must be visually monitored at all times. It is mandatory to make sure that **both** hooks are properly engaged on a mast rung before and after raising or lowering the platform. Failure to engage the hooks correctly may cause the platform to drop, leading to damages to equipment and injury, even death.

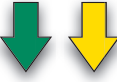
	<p>RAISING the control lever will cause the cylinder to retract and generate an upward motion of the platform</p> <p>GREEN ARROW indicates to raise and hold the control lever until the cylinder retracts completely</p> <p>YELLOW ARROW indicates to raise and hold the control lever until the cylinder has retracted sufficiently for the task to perform</p>
	<p>LOWERING the control lever will cause the cylinder to extend and generate a downward motion of the platform</p> <p>GREEN ARROW indicates to lower and hold the control lever until the cylinder extends completely</p> <p>YELLOW ARROW indicates to lower and hold the control lever until the cylinder has extended sufficiently for the task to perform</p>

Raising the platform

- 1- Before initiating the ascent, make sure that the motorized unit and plank outriggers clear the building, balconies, etc., and that the mast tie door is open and planking has been removed from in front of the mast when passing a tie level.

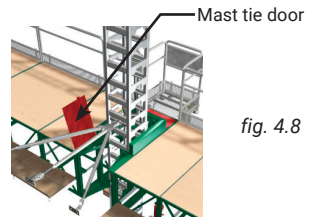

fig. 4.8

- 2- Lock the lowering cam on both the cylinder hook and the secondary hook (fig. 4.9).

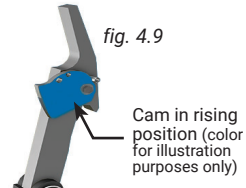

fig. 4.9

- 3- Make sure that the engine is running at full throttle and that the cylinder hook and the secondary hook are properly engaged (fig. 4.10 and fig. 4.11) and on the same mast rung (fig. 4.14, p. 60). Failure to engage the hooks correctly can cause the platform to drop.

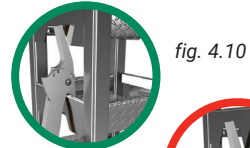

fig. 4.10

Correct

fig. 4.11

Incorrect



CAUTION

Make sure the cylinder hook and the secondary hook are properly engaged (fig. 4.10 and fig. 4.11) and on the same mast rung (fig. 4.14, p. 60) before raising or lowering platform. Failure to engage hooks correctly can cause the platform to drop.

Power Pack and Operating Components

Raising the platform (cont'd)

- 4- Lower the control lever and extend the hydraulic cylinder (to reach the second-to-next rung) (fig. 4.12). The engine will slow down when the cylinder is fully extended.

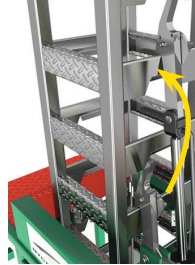

Reach the second-to-next rung

fig. 4.12

- 5- Raise the control lever so the cylinder hook drops slightly, enough to engage onto the mast rung. Before raising the platform, check visually to make sure that the cylinder hook is properly engaged on the mast rung.



fig. 4.13

- 6- Raise the control lever and let the platform rise until the secondary hook is above the rung where the cylinder hook is engaged. The lift can vary from one to two mast rungs.

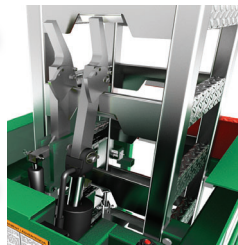

fig. 4.14

- 7- Lower the control lever enough to engage the secondary hook on the mast rung. Both hooks will now be side by side on the same mast rung. The platform will lower slightly at this stage.



- 8- Repeat steps 4 through 7 to continue raising the platform.

- 9- Once the platform has reached the desired height, make sure that both hooks are properly engaged on the same mast rung.



CAUTION

In a twin units configuration, it is **mandatory** to coordinate the rise and descent operation on each motorized unit linked by the bearing bridge to ensure that any slope of the structure does not exceed 2 degrees.



WARNING

The use of fall protection equipment is **mandatory** to handle operations when passing tie levels. Properly tied to the unit, slide planks away from in front of the mast. The use of shorter planks will facilitate this task.

Power Pack and Operating Components

Lowering the platform

- 1- Before initiating descent, make sure that the motorized unit and plank outriggers clear the building, balconies, etc., and that the mast tie door is open and planking has been removed from in front of the mast when passing a tie level.

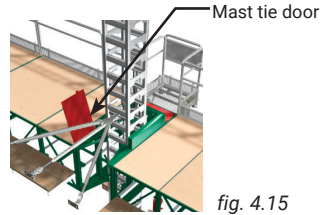

fig. 4.15

- 2- Unlock the lowering cam on both the cylinder hook and the secondary hook (fig. 4.16).

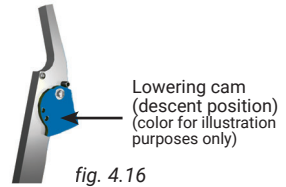

fig. 4.16

- 3- Make sure that the engine is running at full throttle and that the cylinder hook and the secondary hook are properly engaged (fig. 4.17 and fig. 4.18) and on the same mast rung (fig. 4.23, p. 62). Failure to engage the hooks correctly can cause the platform to drop.



fig. 4.17

Correct



fig. 4.18

Incorrect

- 4- Raise the control lever to retract the cylinder completely so the lowering cam of the secondary hook can swing toward the mast. The engine will slow down when the cylinder has retracted completely. At this stage, the platform will rise slightly.

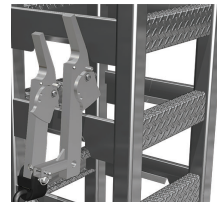

fig. 4.19

- 5- Lower the control lever and extend the hydraulic cylinder. The platform will lower by one to two mast rungs (fig. 4.20). The engine will slow down if the cylinder is fully extended.



fig. 4.20

**CAUTION**

In a twin units configuration, it is **mandatory** to coordinate the rise and descent operation on each motorized unit linked by the bearing bridge to ensure that any slope of the structure does not exceed 2 degrees.

Power Pack and Operating Components

Lowering the platform (cont'd)

6- Raise the control lever so the cylinder retracts itself enough so the secondary hook is above the mast rung (but not its lowering cam). At this stage the platform will rise slightly.



7- Lower the control lever so the secondary hook drops slightly, enough to engage onto the mast rung. At this stage, the platform will lower slightly.



Before lowering the platform, check visually to make sure that the secondary hook is properly engaged on the mast rung.



fig. 4.21

8- Lower the control lever again to extend the cylinder completely and force its lowering cam to swing toward the mast.



fig. 4.22

9- Raise the control lever so the cylinder retracts completely.



10- Lower the control lever to extend the cylinder enough until its hook is above the mast rung (but not its lowering cam).

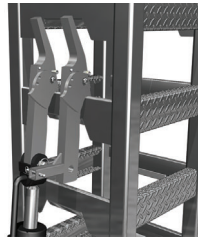

fig. 4.23

11- Raise the control lever so the cylinder hook drops slightly, enough to engage onto the mast rung.



Both the cylinder and secondary hooks will be side by side on the same mast rung.

12- Repeat steps 4 through 11 to continue lowering the platform.

13- Monitor the last 10' (3 m) of descent to base level to ensure proper clearance under and around the lowering platform.

14- Once the platform has been brought down to base level or to the desired height, make sure that both hooks are properly engaged on the same mast rung.



WARNING

The use of fall protection equipment is **mandatory** to handle operations when passing tie levels. Properly tied to the unit, slide planks away from in front of the mast. The use of shorter planks will facilitate this task.



CAUTION

Make sure the cylinder hook and the secondary hook are properly engaged (fig. 4.17 and fig. 4.18, p. 61) and on the same mast rung (fig. 4.23) before and after raising or lowering platform. Failure to engage hooks correctly can cause the platform to drop.

Mast and Mast Ties

Mast Sections

The installation and removal of mast sections must be performed with care to avoid any twisting of the mast that may compromise the proper operation of the motorized unit setup and lead to safety issues.

The front face of mast sections must always be parallel to the face of the work. It is important to verify that the mast remains parallel throughout the installation of mast sections.

Mast sections loaded on the platform using a crane or a rough terrain forklift **must be stored horizontally and distributed equally on either side of the mast to ensure good balance**. Refer to the *Load Capacities* section on p. 73 for more information about loading the platform.

Installation of a single mast section

- 1- Make sure that the motorized unit is positioned properly. Refer to p. 18 of the *Motorized Unit* section for more information. Refer to applicable local regulations governing distances between the mast climbing work platform system, the face of the work and also electrical lines.
- 2- Bring the motorized unit to where the mast section must be installed.
- 3- Using any appropriate lifting device such as a crane or a rough terrain forklift, lift and carry the next mast section.
- 4- Align the mast section to be installed on the mast section already in place. Insert the anti-error stubs on top of the bottom section into the bottom tubes of the section to be installed, making sure the mast sections line up square and that rungs for the hooks are on the same side.
- 5- Flip the 5/8" x 6 1/2" mast bolt, mast clamp and flange nut onto the connecting lug (fig. 5.1) and tighten by hand. Perform this operation for all four (4) corners.
- 6- Tighten all mast bolts with a torque of 120 lb-ft (163 N-m). Use a cross-pattern sequence when tightening (fig. 5.4).
- 7- Repeat steps 2 through 6 for each mast section to be installed at every 5' (1,5 m) of rise.
- 8- Always make sure that the mast assembly is plumb on both the front and side axis.
- 9- It is important to verify the mast bolts when lowering the platform to make sure they are in good condition and are tightened properly, especially on **brand-new mast sections**, as the galvanized coating may have compressed. In all cases, mast bolts must be tightened with a torque of 120 lb-ft (163 N-m). Overtightening or undertightening mast bolts may lead to equipment damage.

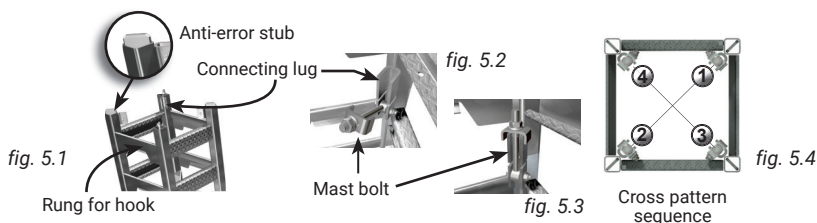

- 10- For the installation of assembled lengths of mast sections, refer to the installation instructions starting on p. 18 of the *Motorized Unit* section, and to the instructions on the use of the multiple mast handler on p. 103 of the *Accessories* section. It is important to verify the mast bolts of assembled lengths of mast to make sure they are tightened properly.

N

NOTICE

It is important to inspect Hydro Mobile M2 and P Series mast sections and mast bolts following the recommended inspection schedules. Failure to inspect mast sections and mast bolts in a timely fashion can lead to equipment damage and premature wear.

Removing a single mast section

- 1- Loosen the mast bolt assembly and disengage from the connecting lug (fig. 5.2).
 - 2- Using any appropriate lifting device such as a crane or a rough terrain forklift, lift the top mast section off the bottom mast section.
- If mast sections are to be stored on the platform during dismantling, make sure they are **set down horizontally and distributed equally on either side of the mast to ensure good balance**. Refer to the *Load Capacities* section on p. 73 for more information about loading the platform.

Mast and Mast Ties

Mast Sections

Transport and storage of mast sections

- 1- Mast sections can be carried in 20' (6,1 m) segments provided they are set down horizontally on a flat surface. Make sure that mast sections bolted together in 20' (6,1 m) segments are secured so as to remain straight during road transport.
- 2- For best results when carrying mast sections in bundles, it is recommended to strap them in groups of nine (9). Make sure that mast sections positioned in the middle are securely strapped to the other sections to prevent them from slipping out during transport.
- 3- Store mast sections on a flat surface away from work areas and construction traffic.



WARNING

It is important to make sure to verify the mast bolts when lowering the platform to make sure they are tightened properly and are in good condition, especially on **brand-new mast sections**, as the galvanized coating may have compressed. Make sure to also verify mast bolts of assembled lengths of mast. In all cases, mast bolts must be tightened with a torque of 120 lb-ft (163 N-m). Overtightening or undertightening mast bolts may lead to equipment damage.

Installation of Tie Levels

General guidelines

- 1- Freestanding configurations are **only allowed for standard P Series configurations**. For the definition of a standard configuration, refer to p. 19 of the *Motorized Unit* section.
- 2- The pre-installation of tie levels consists in the installation of all mast sections and tie levels necessary to reach the total mast height specified in the layout plan, as required and allowed, **before installing any additional accessory or equipment and before beginning normal operation of the setup**. The pre-installation of tie levels is mandatory for P Series installations in non standard configurations. For more information about the installation of standard and non standard configurations, refer to the *Motorized Unit* section, starting on p. 18.
- 3- Determine the mast tie components and the quantity required of each according to the installation method appropriate for the installation, the number of planks required and allowed for the configuration and the height of the mast. For more information about methods of installation, see p. 21 of the *Motorized Unit* section.

Installation of a mast tie attachment assembly

- 1- Slide the mast tie attachment assembly into the mast section. To ensure having the required clearance for climbing up or down the mast, make sure the assembly is positioned under the rung, not above.
- 2- Spread open the mast tie attachment assembly until the four corner stoppers are positioned properly and snug against the mast structure.
- 3- Push the 5/8" x 6 1/2" mast bolt assembly inside the connecting lug to secure the mast tie attachment. Tighten the bolt with a torque of 60 lb-ft (80 N-m).

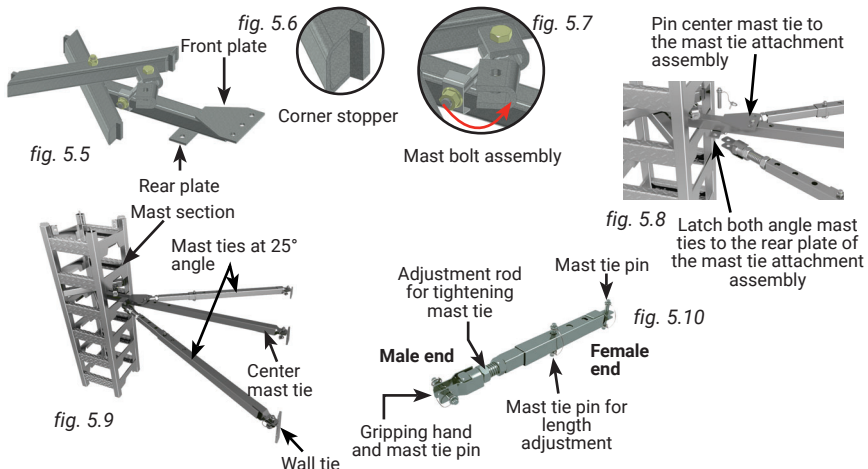

Mast and Mast Ties

Installation of Tie Levels

Installation of standard mast ties

- 4- Refer to the diagrams and the *Mast Tie Components Requirements* table below to choose the mast tie components appropriate for the planking configuration required by the setup.
- 5- Pin the required center mast tie to the mast tie attachment using a clevis pin and a linch pin.
- 6- Pin the gripping hand of the center mast tie to the wall tie and adjust its length until the mast is perfectly plumb on the front axis. Use the threaded rod and the pin for adjustment, leaving a maximum length of threaded rod inside the mast tie tube for added strength. The tie adjustment rod has a maximum extension of 6" (15,5 cm).
- 7- Pin the other two mast ties to the rear plate of the mast tie attachment bracket at a 25° angle (fig. 5.9, p. 64) and use the threaded rods and the pins to adjust their length until the mast is perfectly plumb on the side axis.

Mast Tie Requirements for Planking Configurations

fig. 5.11

Mast Tie Components Requirements							
COMPONENTS							
Number of planks	①	②	③	④	⑤	H	C
	Mast tie short assembly	Mast tie short male assembly	Mast tie assembly	Mast tie male assembly	Mast tie extension	Distance from motorized unit to face of work	Center to center distance
0	2	1	0	0	0	6" (15,2 cm)	12" (30,5 cm)
1	3	0	0	0	0	16" (40,6 cm)	14" (35,6 cm)
2	0	0	2	1	0	26" (66 cm)	21" (53,3 cm)
3	0	0	3	0	0	36" (91,4 cm)	23" (58,4 cm)
4	0	0	3	0	0	46" (116,8 cm)	28" (71,1 cm)
5	2	0	1	0	2	57" (144,8 cm)	33" (83,8 cm)

1. Parts required are based on number of planks x 10" (25,4 cm) + 6" to 8" (15 cm to 20 cm) of play for planking configurations of up to 4 planks and 3" to 6" (7,6 cm to 15,2 cm) of play for 5-plank configurations.
 2. The H and C/C distances are given only as a reference. Tolerance rate is of ± 2" (5 cm).

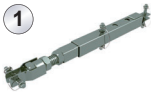

fig. 5.12
Mast tie short assembly

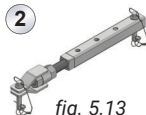

fig. 5.13
Mast tie short male assembly



fig. 5.14
Mast tie assembly

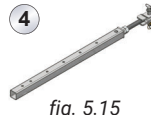

fig. 5.15
Mast tie male assembly

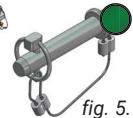

fig. 5.16
Mast tie pin assembly

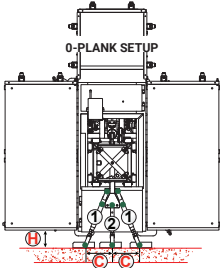

fig. 5.17

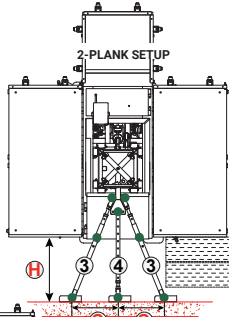

fig. 5.18

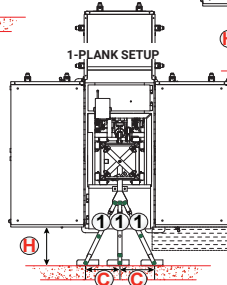
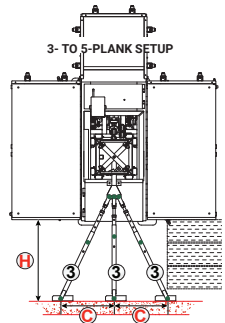

fig. 5.19

fig. 5.20



Mast and Mast Ties Installation of Tie Levels

fig. 5.21

Tie Level Installation Schedule				
		1	2	3
A	A (from under the base)	Up to 20' (6,1 m)	Up to 20' (6,1 m)	No more than 10' (3 m)
B	B (from A)	Up to 20' (6,1 m)	Up to 20' (6,1 m)	Up to 20' (6,1 m)
C	C (from B) and subsequent	Up to 20' (6,1 m)	Up to 20' (6,1 m)	Up to 20' (6,1 m)
D	Maximum travel distance above last tie level	Up to 20' (6,1 m)	NOT ALLOWED	See 1 or 2, as applicable
Freestanding height allowed (without adapter base)		Up to 20' (6,1 m)	NOT ALLOWED	NOT ALLOWED
*	If base outriggers are required to be closed completely , it is mandatory to refer and comply with the Tie Level Installation Schedule for an installation with a mast base plate, on p. 102 of the Accessories section.			

	WARNING
It is important to inspect every component of a motorized unit installation that has been exposed to conditions that could have compromised or altered the structural integrity and stability of the installation.	

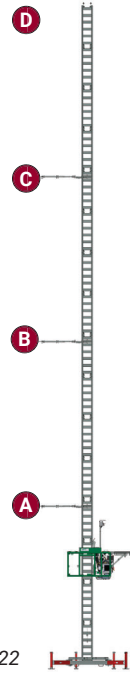

fig. 5.22

fig. 5.23

Type of installation		
1	Standard configuration - single unit or twin units	Pre-installation or progressive installation
2	Non standard configuration - single unit or twin units	Pre-installation mandatory
3	Front base outriggers parallel to face of work	Progressive if standard configuration Pre-installation mandatory if non standard configuration

<p>Definition of the pre-installation of a setup</p> <p>The pre-installation of a setup, referred to throughout this owner's manual and related documentation, consists in installing all required mast sections and tie levels to reach the total mast height specified in the layout plan before installing any additional equipment or accessory and before starting any work.</p> <p>It is mandatory to use this method for any non standard configuration.</p>

Mast and Mast Ties

Installation of Tie Levels

Passing tie levels

The use of fall protection equipment is **mandatory** to handle operations when passing tie levels. To safely pass tie levels, slide planks away from the front area of the mast and open the mast tie door. The use of shorter planks will facilitate this task. It is recommended to use the designated tie points located on the motorized unit and on the substructure to anchor the fall protection equipment.

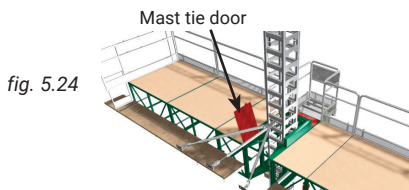

fig. 5.24



The use of shorter planks will facilitate the passing of tie levels.

Removing mast ties

- 1- Loosen the adjustment rod on one of the angle mast ties until the mast tie is loose enough to be easily unfastened from the wall tie installed on the face of the work.
- 2- Repeat step 1 for the other angle mast tie, then for the center mast tie. The center mast tie must be the last mast tie removed.

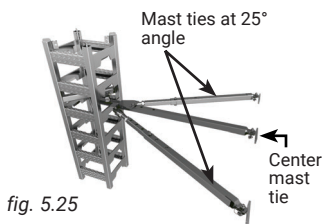

fig. 5.25

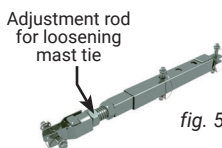

fig. 5.26



CAUTION

It is mandatory to make sure that **all tension** (or **compression**) is **released** from the mast tie **before** attempting to loosen the clamp and unpin the mast tie from the wall tie.



WARNING

The **erection** and **dismantling** of a motorized unit setup (including the base, the bridges, the masts, the mast ties and all the other components) must not be conducted when wind speeds exceed **28 mph (45 km/h)**. Freestanding installations and setups equipped with weather protection, when allowed, must not be used with wind speeds exceeding **28 mph (45 km/h)**. Weather protection, when allowed, must not be used when work is performed on an open air structure. A motorized unit with mast ties must not be used when wind speeds exceed **35 mph (56 km/h)**. It is important to inspect every component of a motorized unit installation that has been exposed to conditions that could have compromised or altered the structural integrity and stability of the installation.

When the motorized unit is not in use:

- It is mandatory to bring the platform down to base level or to leave the platform between two tie levels.
- All loads must be removed from the platform.
- It is mandatory to leave all the counterweights applied on the setup in place.
- In a freestanding installation, when allowed, the motorized unit must be brought down to base level.
- If wind speeds are expected to exceed **94 mph (150 km/h)**, the motorized unit must be brought down to base level.

Mast and Mast Ties

Correction of a Twist in a Mast

The presence of a twist in a mast can compromise the proper operation of a P Series installation and lead to serious safety issues. An installation that is no longer parallel to the face of the work may cause the last cantilever bridge of the installation to come into contact with the face of the work, leading to damages to the equipment and possibly injuries.

It is important to correct any twist of the mast installation quickly and efficiently. A specific method of installation of mast ties can be used to correct the twist. Particular care must be taken when choosing the direction in which to rotate the mast. The following steps apply to a **clockwise rotation** of the mast. For **counterclockwise rotation**, adapt the following steps by inverting left and right positions. It is important to note that the following method of installation must not be used for the standard installation of mast ties.

- 1- Pin a mast tie to the left position on the rear plate (fig. 5.28) of the mast tie attachment assembly and attach it at a **straight angle** ("1", in fig. 5.27) to the face of the work. Using the threaded rod, adjust its length until the mast is perfectly plumb on its front axis. The tie adjustment rod has a maximum extension of 6" (15,5 cm)
- 2- Install the first angle mast tie ("2", in fig. 5.27) at the right position on the rear plate of the mast tie attachment assembly. Attach the mast tie to the face of the work at an angle of 25 degrees from the straight angle mast tie installed in step 1. Using the threaded rod, adjust its length until the mast is perfectly plumb on its side axis.
- 3- Pin the second angle mast tie ("3", in fig. 5.27) to the right position on the front plate. Attach the mast tie to the face of the work at an angle of 25 degrees from the straight angle mast tie installed in step 1.
- 4- Holding a straight edge of at least 4' (1,2 m) long horizontally on the face of the mast section, measure the distance between each end ("A" and "B", fig. 5.29) and the face of the work. Using the threaded rod, adjust the length of the angle mast tie installed in step 3 until both distances are equal.

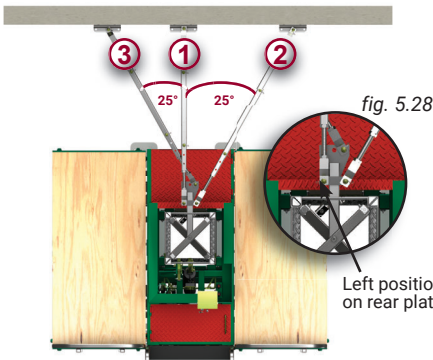

fig. 5.27

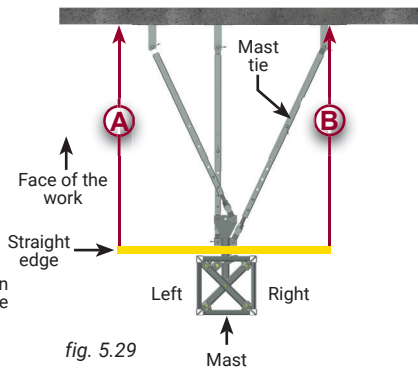

fig. 5.29

Angled Mast Ties

Some mast tie configurations require that the mast ties be installed at an angle (between 5 and 30 degrees from horizontal) through windows or other building openings (fig. 5.32). Configurations for anchoring mast ties at an angle can only be achieved with a **type 2 mast tie bracket** (fig. 5.31).

These angled anchoring configurations require the use of the optional 30-degree mast tie kit (fig. 5.33, p. 69) and wall ties for horizontal anchoring installations. An angled anchoring installation **must not exceed** a 30-degree angle from horizontal (fig. 5.39, p. 70).

Each mast tie in an angled mast tie configuration must only be a combination of one standard mast tie assembly and **only one** optional mast tie extension.



fig. 5.30

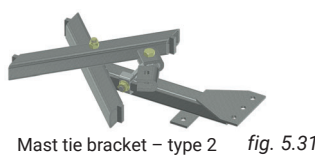

fig. 5.31



fig. 5.32

Mast and Mast Ties

Angled Mast Ties

Installation of the 30-degree mast tie installation components

- 1- Make sure that the mast tie bracket is appropriate and installed correctly. For instructions on the installation of a mast tie bracket, refer to p. 64 of this section.
- 2- Insert the top part ("A" in fig. 5.33) of the 30-degree mast tie attachment bracing assembly in the mast, over the mast tie attachment assembly. Make sure both bars are properly inserted in the front and back mast rungs and that the fillers (welded tubes) are positioned on top of the lower tube of the mast tie attachment assembly (fig. 5.34).
- 3- Insert the bottom part of the 30-degree mast tie attachment bracing assembly ("B" in fig. 5.33) under the mast tie attachment assembly.

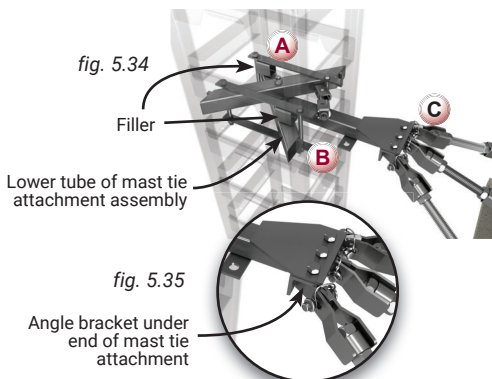
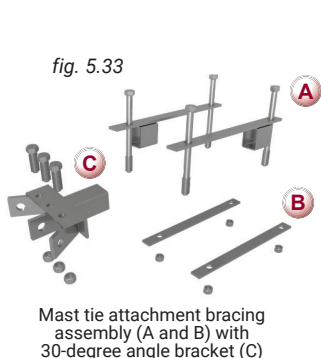

- 4- Align the top and bottom parts of the 30-degree mast tie attachment bracing assembly. Assemble both parts with four 5/8" bolt and nut assemblies. **Do not tighten bolt assemblies yet.**
- 5- Slide the tube of the angle bracket ("C" in fig. 5.21) into the tube of the mast tie attachment assembly. Secure the angle bracket to the mast tie attachment assembly with three 9/16" bolt assemblies.
- 6- Tighten all bolt assemblies with a torque of 60 lb-ft (81 N-m).



NOTICE

An angled mast tie installation **must not exceed** a 30-degree angle from horizontal. Only **one** optional mast tie extension is allowed for **each** mast tie in an angled mast tie configuration.

Assembly of an extended mast tie

- 1- Remove the mast tie pin holding both ends of the mast tie assembly together.
- 2- Insert the male part of the mast tie assembly ("D" in fig. 5.38, p. 70) into the female end of the mast tie extension ("E" in fig. 5.38, p. 70) and secure with a mast tie pin.
- 3- Insert the male end of the mast tie extension ("F" in fig. 5.38, p. 70) into the female end ("G" in fig. 5.38, p. 70) of the mast tie assembly and secure with a mast tie pin.
- 4- Repeat steps 1 through 3 for each required extended mast tie.

Installation of extended mast ties

- 1- Pin an extended mast tie to the center of the mast tie attachment using a clevis pin and a linch pin.
- 2- Pin the center mast tie to the floor tie and adjust its length until the mast is perfectly plumb on the front axis. Use the threaded rod and the pin for adjustment, leaving a maximum length of threaded rod inside the mast tie tube for added strength. The tie adjustment rod has a maximum extension of 6" (15.5 cm). Floor ties must be able to sustain 1500 lb (680 kg) of tension/compression and 3000 lb (1361 kg) of shear force.

Mast and Mast Ties

Angled Mast Ties

Installation of extended mast ties (cont'd)

3- Repeat steps 1 and 2 to install the other required extended mast ties at a 25° angle and use the threaded rods to adjust their length until the mast is perfectly plumb on the side axis.

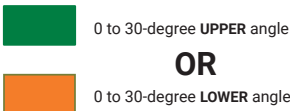
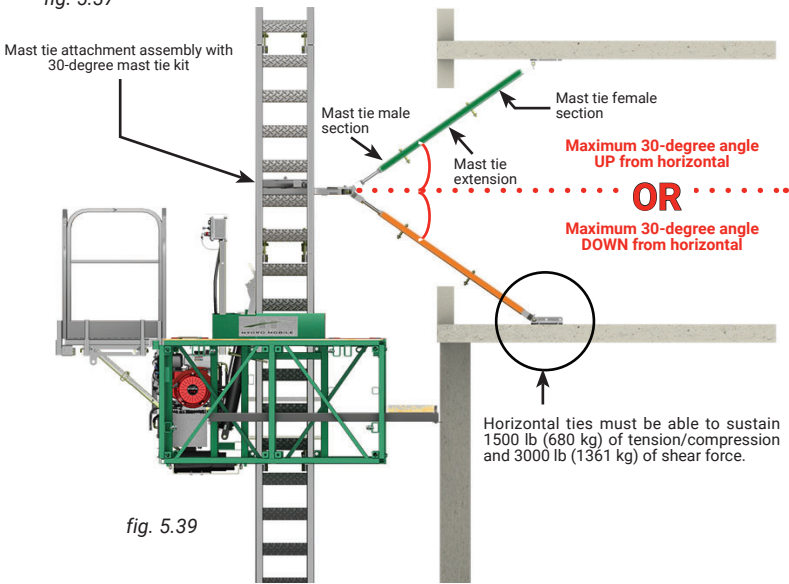
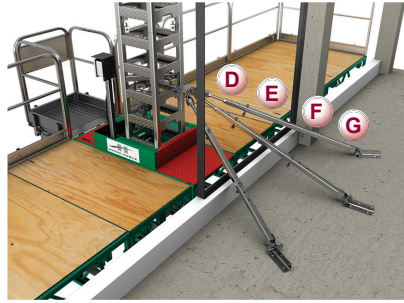
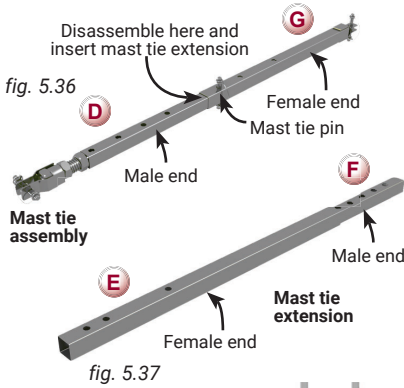

Calculation of a mast tie angle

A 5-degree slope represents a 12" to 1" (30 cm to 2,5 cm) ratio

A 30-degree slope represents a 12" to 7" (30 cm to 18 cm) ratio

Mast and Mast Ties

Anchoring System

Wall tie reactions

Before attaching masts to the building using the mast tie system, wall ties must be installed on a solid component of the building structure. It is important to understand that whether the anchoring installation is a vertical or horizontal type (fig. 5.42 and fig. 5.43), values for tension / compression and shear forces will be **inverted**.

Concrete slabs, columns, steel beams, relief angles and other structural elements can be used provided they and the anchoring system chosen can sustain 3000 lb (1361 kg) of tension / compression and 1500 lb (680 kg) of shear force for a **vertical anchoring installation** and 1500 lb (680 kg) of tension / compression and 3000 lb (1361 kg) of shear force for a **horizontal anchoring installation**.

There are 4 types of wall ties that can be used. As the installation is rising, install wall ties as per the *Tie Level Installation Schedule* (p. 66). **It is important to note that M1 Series wall ties do not meet minimum strength requirements for setups using current Hydro Mobile equipment.**

Most anchor fastener manufacturers specify a maximum distance from the edge of a slab at which an anchor fastener must be installed to obtain its maximum working load. The thinner the slab, the less available area there is to maximize that working load. The site engineer is responsible for verifying and giving final approval on anchor selection and building structure capabilities.

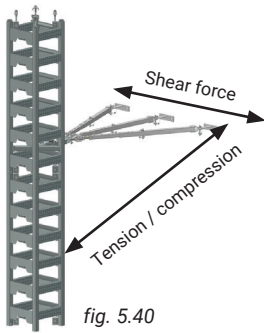

fig. 5.40



fig. 5.42

Horizontal anchoring installation



fig. 5.41

Anchor fastener



fig. 5.43

Vertical anchoring installation

Each anchor fastener shown in fig. 5.41 must be able to sustain appropriate tension / compression and shear force for the application. Refer to the installation guidelines for each type of anchoring (horizontal or vertical) further on in this section for more information. A total of six anchor fasteners (minimum two per wall tie bracket) is required for each tie level.

Wall tie types

There are 4 types of wall ties that can be used – welded, re-usable (centered or offset) and for horizontal/vertical installation. As the installation is rising, install the wall ties as per the appropriate tie level installation schedule (see p. 66).



fig. 5.44

Welded wall tie



fig. 5.45

Re-usable wall tie (offset)



fig. 5.46

Re-usable wall tie (centered)



fig. 5.47

Wall tie for horizontal or vertical anchoring installation



fig. 5.48

Fixed wall tie (4" or 10 cm only)

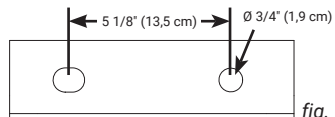

fig. 5.49

Drill-hole template for all wall ties

WARNING

It is mandatory to refer and conform to the anchor fastener manufacturer's specifications for the capacity, embedment, required distance from edge and application reduction factors of the fastener, manufacturer's recommended installation method, etc.

Mast and Mast Ties

Anchoring System

Installation guidelines for horizontal anchoring

Horizontal anchoring can be installed at angles ranging from 0° up to 30° from horizontal. Wall ties used for horizontal anchoring installations must be able to sustain 1500 lb (680 kg) of tension/compression and 3000 lb (1361 kg) of shear force.

Installation guidelines for a re-usable wall tie

Used mainly for masonry work projects, the re-usable wall tie is installed in a cavity left unfilled in a brick wall under construction.

When dismantling the setup and removing mast ties, the re-usable wall tie is removed and the brickwork is completed.

Installation guidelines for fixed wall ties

Fixed wall ties can be installed on a wall between two layers of brick (fig. 5.50). It is important to make sure that several layers of brick have been laid on top of the fixed wall ties and that the mortar has cured properly **before attaching mast ties to the wall ties.**

Distance between the anchoring structure and the back of the brick wall must not be greater than 1 1/2" (3,8 cm), as shown in fig. 5.51.

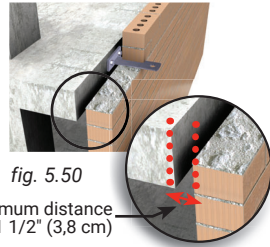

fig. 5.50

Maximum distance
1 1/2" (3,8 cm)

fig. 5.51

Installation guidelines for a welded wall tie on a beam

The welded wall tie is 6 7/8" (17,5 cm) long and must protrude from the beam by a maximum of 3 7/8" (10 cm). If an angled mast tie will be attached to the welded wall tie, the wall tie must be installed at the same angle as the mast tie.

When a welded wall tie is installed at an angle, as shown in fig. 5.54, the maximum length of 3 7/8" (10 cm) must be calculated on the longest side of the angled wall tie.

The welding electrode used must be E70-XX series.

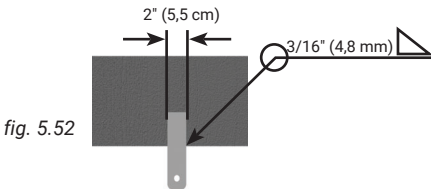
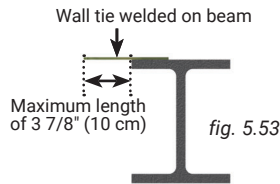

fig. 5.52



Maximum length
of 3 7/8" (10 cm)

fig. 5.53

Maximum length of 3 7/8" (10 cm) must be measured on the longest side if the wall tie is at angle

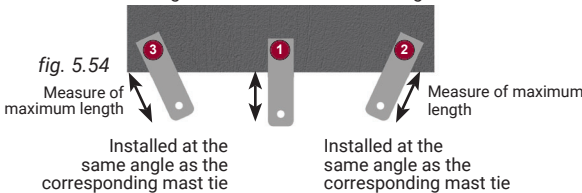

fig. 5.54

Measure of
maximum length

Measure of maximum
length

Installed at the
same angle as the
corresponding mast tie

Installed at the
same angle as the
corresponding mast tie



fig. 5.55

Mast ties for P Series
narrow setups shown for
illustration purposes

Load Capacities

General guidelines

- 1- The weight of planks and any additional accessory being used must be deducted from the load capacities.
- 2- Each worker's weight (personal tools and equipment included) must be deducted from load capacities.
- 3- The load capacity charts stickers displayed on the motorized unit used in the setup will take precedence over the information included in this owner's manual.
- 4- To ensure stability it is recommended that the loads applied on the platform be as evenly distributed as possible.
- 5- To ensure stability in a single unit setup, the length of cantilever bridges on either side of the unit must be equal at all times, unless otherwise shown in load capacity charts for specific configurations using a front or rear extension, a swivel bridge, etc.
- 6- To ensure stability in a twin units setup, the minimum load applied on the bearing bridge must be similar to the total load applied on the cantilever bridges.
- 7- It is recommended that there be a **maximum** number of workers for each installation, calculated as follows: overall length of installation divided by 15' (4,6 m) and rounded **up**, **PLUS** two workers for each motorized unit in the installation, with at least one of those two workers being a qualified operator of a P Series motorized unit and its accessories. For example, on a setup with an overall length of 63' 4" (19,3 m), the calculation would be: $63' 4" / 15$ (or $19,3 \text{ m} / 4,6 \text{ m}$) rounded up to **5**, **PLUS two workers for each** motorized unit (in this case, two units) = **4**, resulting in a **maximum of 9 workers** for the installation, including **two qualified operators**. Refer to p. 7 of the *Performance and Safety Rules* section for the definition of a qualified operator.

Calculating the maximum number of workers allowed on a given installation

Formula	Calculation example for a 63' 4" (19,3 m) installation
Overall length of installation / 15' (4,6 m), rounded up	$63' 4" (19,3 \text{ m}) / 15' (4,6 \text{ m})$, rounded up → 5
+	+
Two (2) workers per motorized unit in the installation	Two (2) workers for each motorized unit in the installation → 4
	Total of workers allowed on installation → 9

fig. 6.1



NOTICE

The load capacities charts stickers displayed on the motorized unit used in the setup will take precedence over the information included in this owner's manual.



WARNING

To ensure safety at all times on a mast climbing work platform system, bridges must not be loaded beyond their maximum rated weight capacities. In addition, to prevent a mast climbing work platform system from stalling because of an overload, maximum rated load capacities of the motorized unit(s) must be observed. Overloading a mast climbing work platform system could result in serious injury or death.

Make sure that there are never two workers standing on the same plank outrigger at the same time.

Load Capacities

General guidelines (cont'd)

- 8- The weight of each person working in a given area reduces the load capacity of that area.
- 9- Twin unit setups can be a combination of any cantilever bridge configuration with any bearing bridge shown on the charts. The maximum length of cantilever bridge allowed for a P Series installation is 12' 6" (4,1 m). The maximum length of bearing bridge allowed for a P Series installation is 45' (13,7 m).
- 10- In the single unit and twin units installation charts shown in the following pages, the 5' (1,5 m) bridge is used to illustrate capacities. On setups using 10' (3 m) bridges, the load deposited on the 10' (3 m) bridge must be distributed in the same way it is distributed over two 5' (1,5 m) bridges on the chart, as shown in fig. 6.2, below.



fig. 6.2

- 11- To calculate the load capacity of a standard, authorized single or twin units configuration that is not shown in the charts included in this manual, take the length of the bridge to be installed and refer to the capacities of the bridge in the chart that is longer and closest to it. For example, for a 42' 6" (13 m) bearing bridge, the load capacities of a 45' (13,7 m) bearing bridge would be used.

Load Capacities

Evenly distributed – Single unit setup

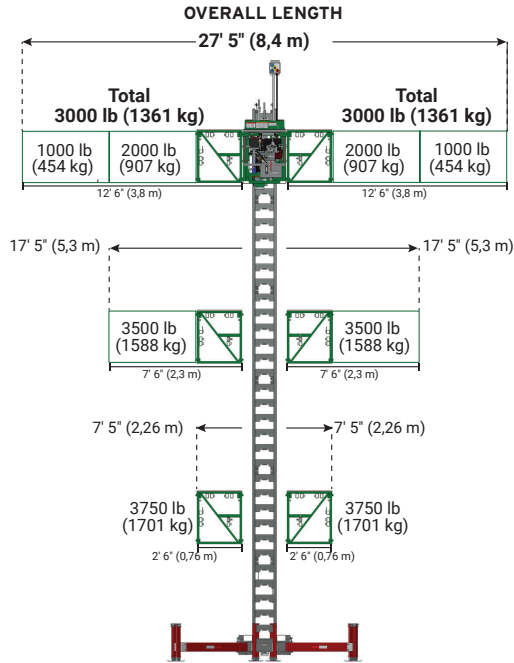

fig. 6.3

To calculate the load capacity of a standard, authorized configuration not shown in the chart above, refer to step of the *General Guidelines* on p. 73 of this section.

LEGEND			
	5' (1,5 m) bridge	or	Bearing bridge adapter
or	30" (76 cm) bridge or multi-purpose bridge		Counterweight
			Bridge used as an extension

Load Capacities

Rear / front extension – Bearing bridge setup

N

NOTICE

Pre-installation of all required mast sections and tie levels to reach the total mast height specified in the layout plan is mandatory for non standard configurations. For more information about non standard configurations, refer to the *Methods of Installation* table on p. 21. of the *Motorized Unit* section.

Bearing bridge setup with rear extension

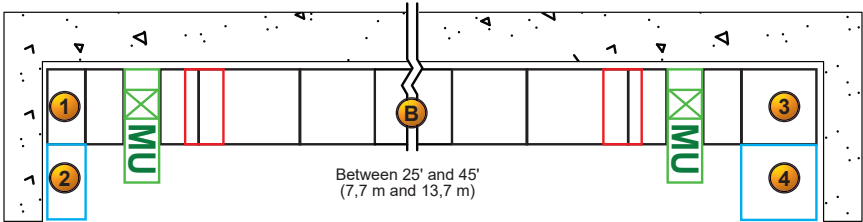

fig. 6.5

Capacity for area

- ① 1500 lb (680 kg)
 - ② 300 lb (136 kg)
 - ③ 1000 lb (454 kg)
 - ④ 300 lb (136 kg)
- Ⓑ For the load capacities of the bearing bridges in the setups illustrated in fig. 6.5, refer to the bearing bridge capacities illustrated in fig. 6.4, p. 76.

Bearing bridge setup with front extension

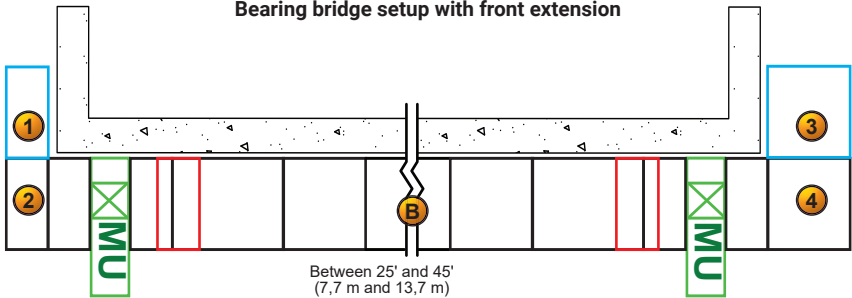

fig. 6.6

Capacity for area

- ① 500 lb (227 kg)
 - ② 1500 lb (680 kg)
 - ③ 500 lb (227 kg)
 - ④ 1500 lb (680 kg)
- Ⓑ For the load capacities of the bearing bridges in the setups illustrated in fig. 6.6, refer to the bearing bridge capacities illustrated in fig. 6.4, p. 76.

LEGEND

- 5' (1,5 m) bridge
- 30" (76 cm) bridge or multi-purpose bridge
- or Bearing bridge adapter
- Counterweight
- Bridge used as an extension



To ensure safety at all times, refer to notes and warning on p. 73 for more information on load capacities.

Load Capacities

Rear / front extension – Cantilever bridge setup (30" (76 cm) or multiple purpose bridge)

N

NOTICE

Pre-installation of all required mast sections and tie levels to reach the total mast height specified in the layout plan is mandatory for non standard configurations. For more information about non standard configurations, refer to the *Methods of Installation* table on p. 21. of the *Motorized Unit* section.

Cantilever bridge setups with a rear extension [30" (76 cm) or multi-purpose bridge]

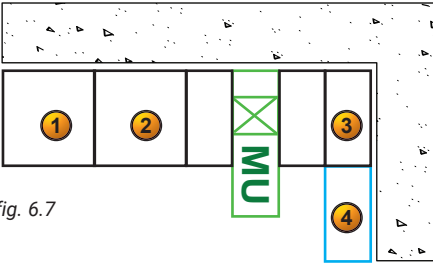

fig. 6.7

Capacity for area

- 1 500 lb (227 kg)
- 2 750 lb (340 kg)
- 3 2000 lb (907 kg)
- 4 500 lb (227 kg)

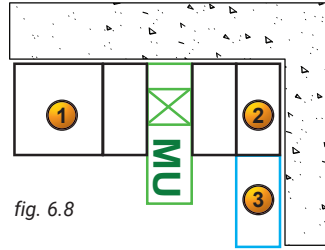

fig. 6.8

Capacity for area

- 1 1750 lb (794 kg)
- 2 2000 lb (907 kg)
- 3 500 lb (227 kg)

Cantilever bridge setups with a front extension [30" (76 cm) or multi-purpose bridge]

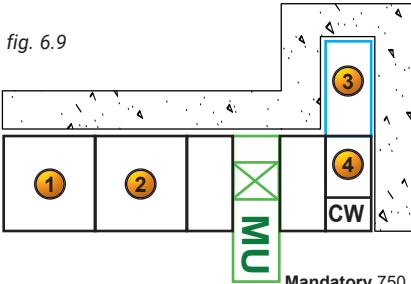

fig. 6.9

Capacity for area

- 1 500 lb (227 kg)
- 2 750 lb (340 kg)
- 3 750 lb (340 kg)
- 4 1750 lb (794 kg)

Mandatory 750 lb (340 kg) counterweight (CW) located within 21" (53 cm) from edge of bridge

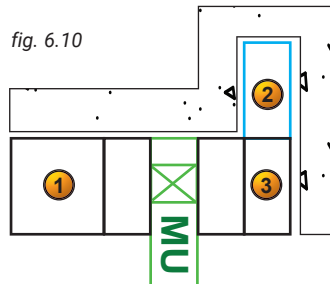

fig. 6.10

Capacity for area

- 1 1750 lb (794 kg)
- 2 1000 lb (454 kg)
- 3 1500 lb (680 kg)

LEGEND

- 5' (1.5 m) bridge
- 30" (76 cm) bridge or multi-purpose bridge
- or Bearing bridge adapter
- Counterweight
- Bridge used as an extension



To ensure safety at all times, refer to notes and warning on p. 73 for more information on load capacities.

Load Capacities

5' (1,5 m) Rear / front extension – Cantilever bridge setup

NOTICE
 Pre-installation of all required mast sections and tie levels to reach the total mast height specified in the layout plan is mandatory for non standard configurations. For more information about non standard configurations, refer to the *Methods of Installation* table on p. 21. of the *Motorized Unit* section.

Cantilever bridge setups with a 5' (1,5 m) front extension

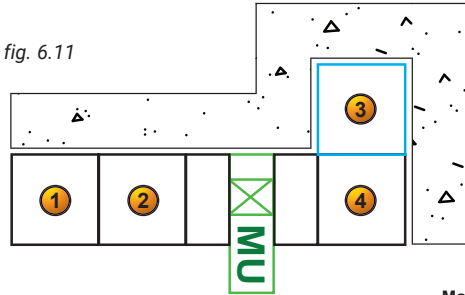

fig. 6.11

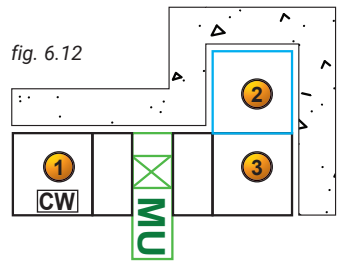

fig. 6.12

Capacity for area

- 1 300 lb (136 kg)
- 2 1000 lb (454 kg)
- 3 750 lb (340 kg)
- 4 1750 lb (794 kg)

Mandatory 750 lb (340 kg) counterweight (CW) located within 21" (53 cm) from edge of bridge

Capacity for area

- 1 2000 lb (907 kg)
- 2 750 lb (340 kg)
- 3 1500 lb (680 kg)

Cantilever bridge setups with a 5' (1,5 m) rear extension

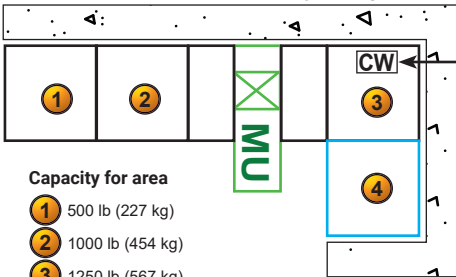

fig. 6.13

Capacity for area

- 1 500 lb (227 kg)
- 2 1000 lb (454 kg)
- 3 1250 lb (567 kg)
- 4 300 lb (136 kg)

Mandatory 500 lb (227 kg) counterweight (CW) located within 21" (53 cm) from edge of bridge

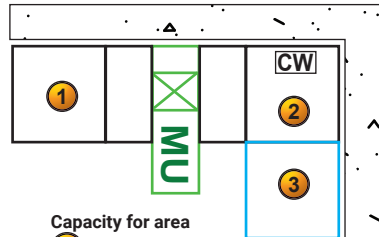

fig. 6.14

Capacity for area

- 1 2750 lb (1247 kg)
- 2 750 lb (340 kg)
- 3 300 lb (136 kg)

LEGEND

- 5' (1,5 m) bridge
- or 30" (76 cm) bridge or multi-purpose bridge
- or Bearing bridge adapter
- Bridge used as an extension
- Counterweight

To ensure safety at all times, refer to notes and warning on p. 73 for more information on load capacities.

Load Capacities

N

NOTICE

Pre-installation of all required mast sections and tie levels to reach the total mast height specified in the layout plan is mandatory for non standard configurations. For more information about non standard configurations, refer to the *Methods of Installation* table on p. 21. of the *Motorized Unit section*.

Swivel bridge installation – Single unit (Front 90 degrees)

At this end, it is mandatory to install a bridge. The only bridge configurations allowed are a cantilever bridge measuring exactly 7' 6" (2,3 m)

– OR –

any bearing bridge configuration shown in the load capacities charts for twin unit setups (see fig. 6.4, p. 76).

NO CONFIGURATION OTHER THAN THOSE ABOVE ALLOWED AT THIS END

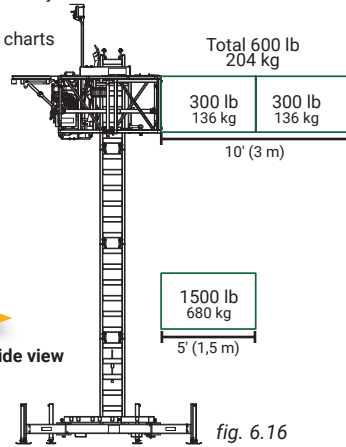
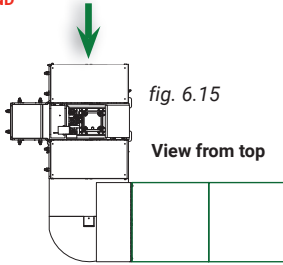

Swivel bridge installation – Single unit (Front 0-45 degrees)

At this end, it is mandatory to install a bridge. The only bridge configurations allowed are a cantilever bridge measuring at least 7' 6" (2,3 m) and a maximum of 12' 6" (4,1 m)

– OR –

any bearing bridge configuration shown in the load capacities charts for twin unit setups (see fig. 6.4, p. 76).

NO CONFIGURATION OTHER THAN THOSE ABOVE ALLOWED AT THIS END

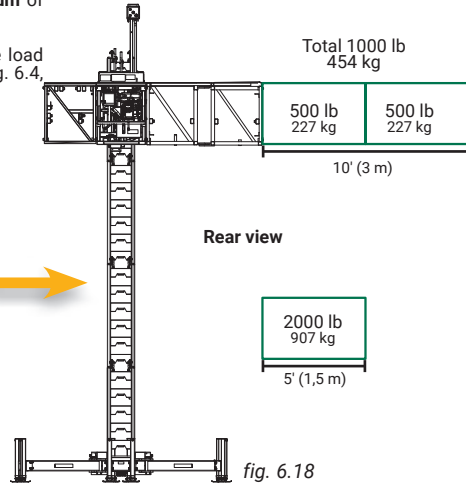
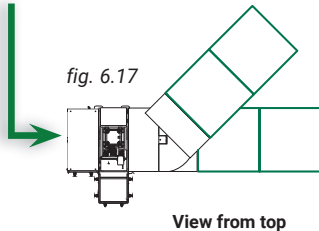

LEGEND

5' (1,5 m) bridge assembly

Length of bridge setup



To ensure safety at all times, refer to notes and warning on p. 73 for more information on load capacities.

Load Capacities

fig. 6.20

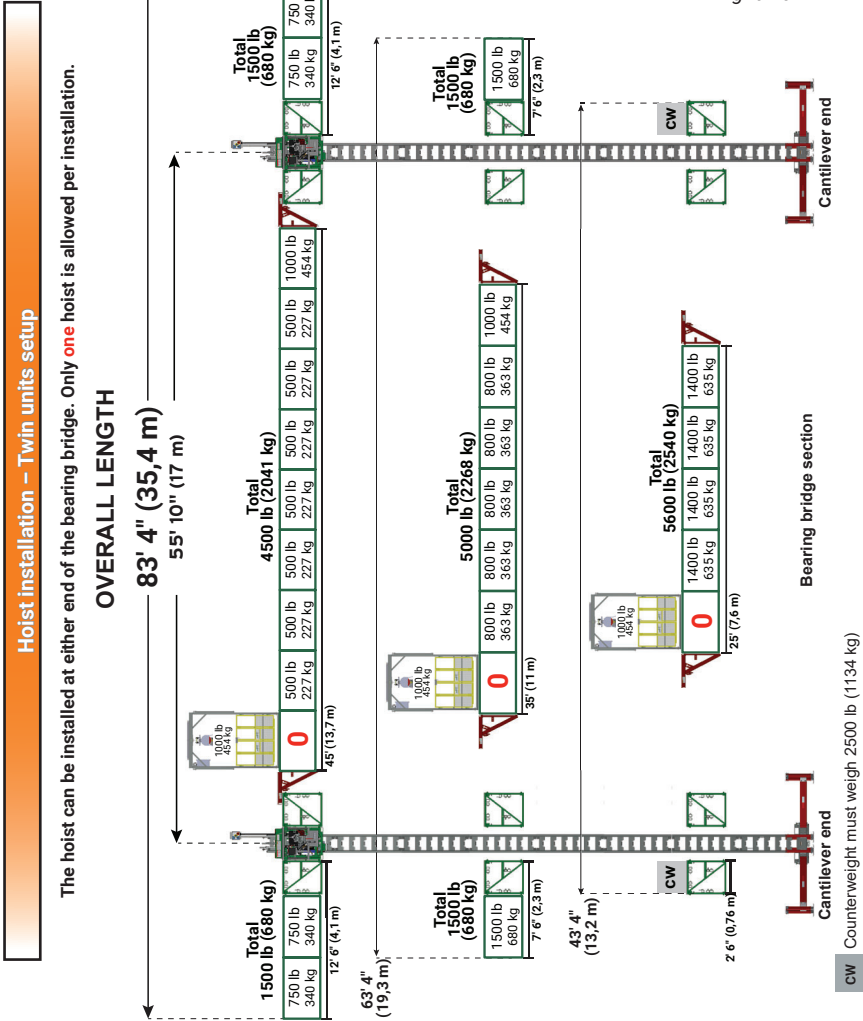

Accessories

SAFETY comes first. While most hazards that may occur when operating a P Series motorized unit setup can be avoided by using extreme care and common sense, the use of safety accessories, such as a rest platform and appropriate guardrails and supports, is recommended when areas and activities involve heights or positioning of the setup that put workers at risk.

Guardrails

In all cases where workers are exposed to fall hazards greater than specified by local regulations, the installation of appropriate guardrails is **mandatory** to ensure safety.

Installation of a guardrail adapter bracket

- 1- Slide a guardrail adapter L bracket (fig. 7.1) in each of the two guardrail pockets and secure them with toggle pins.
- 2- Insert the guardrail legs in the vertical part of the adapter brackets and tighten the bolts on the adapter brackets to secure the guardrail.

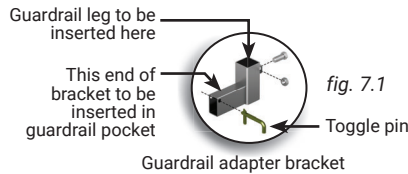

27" (69 cm) guardrail with panel

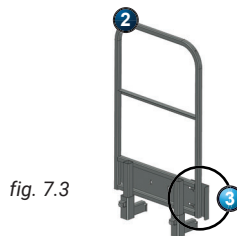

27" (69 cm) guardrail with gap filler

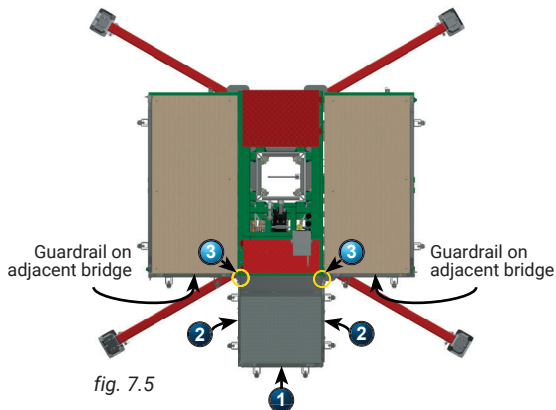
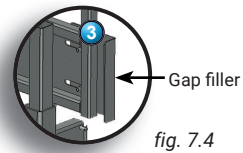

Accessories

Guardrails

Installation of the 27" (69 cm) guardrail with panel on the rear extension platform

- 1- Make sure that the rear extension platform is lifted.
- 2- Make sure the two guardrail adapter brackets are installed in the guardrail pockets on the rear extension platform (see "1" in fig. 7.5, p. 83 for the location of pockets).
- 3- Insert the guardrail legs in the vertical part of the adapter brackets. Tighten the bolts on the adapter brackets with a torque of 30 lb-ft (41 N-m) to secure the guardrail.

Installation of the 27" (69 cm) guardrails on the rear extension platform

- 1- Make sure that the rear extension platform is lifted.
- 2- Make sure that two guardrail adapter brackets are installed in the guardrail pockets at one end of the rear extension platform (see "2" in fig. 7.5, p. 83 for the location of pockets).
- 3- Insert the guardrail legs in the vertical part of the adapter brackets. Tighten the bolts on the adapter brackets with a torque of 30 lb-ft (41 N-m) to secure the guardrail.
- 4- Repeat to install the guardrail at the other end of the rear extension platform.

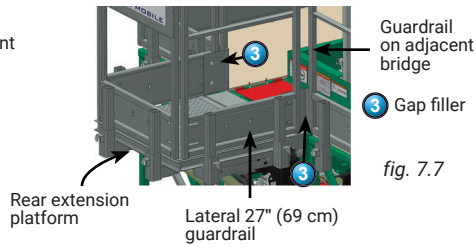
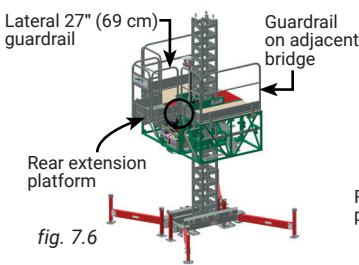

Adjustment of gap fillers on 27" (69 cm) guardrails

The lateral 27" (69 cm) guardrails are equipped with adjustable gap fillers to fill the gaps between the rear extension platform guardrails and guardrails installed on bridges adjacent to the motorized unit. The adjustment of the gap fillers is required.

- 1- Make sure that the gap filler on each of the lateral 27" (69 cm) guardrails is positioned at the end that is close to the adjacent guardrail (fig. 7.7).
- 2- Pull out each gap filler until it reaches the adjacent guardrail and tighten the bolts to secure in place.

Installation of a 60" (152 cm) guardrail

- 1- Make sure the two guardrail adapter brackets are installed in the guardrail pockets at the top of the 5' (1,5 m) bridge.
- 2- Insert the guardrail legs in the vertical part of the adapter brackets. Tighten the bolts on the adapter brackets with a torque of 30 lb-ft (41 N-m) to secure the guardrail.
- 3- Make sure to lock all guardrails together properly.

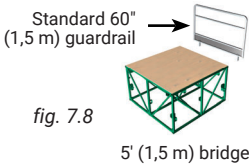

Accessories

Guardrails

Installation of a 30" (76 cm) guardrail

- 1- Make sure the two guardrail adapter brackets are installed in the guardrail pockets at the top of the 30" (76 cm) bridge.
- 2- Insert the guardrail legs in the vertical part of the adapter brackets. Tighten the bolts on the adapter brackets with a torque of 30 lb-ft (41 N-m) to secure the guardrail.
- 3- Make sure to lock all guardrails together properly.

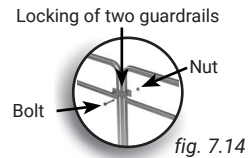
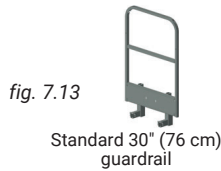
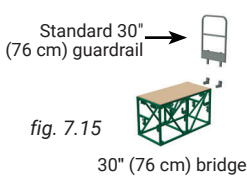

Installation of a 33" (81 cm) guardrail

- 1- Make sure the two guardrail adapter brackets are installed in the guardrail pockets at the top of the multi purpose bridge.
- 2- Insert the guardrail legs in the vertical part of the adapter brackets. Tighten the bolts on the adapter brackets with a torque of 30 lb-ft (41 N-m) to secure the guardrail.
- 3- Make sure to lock all guardrails together properly.

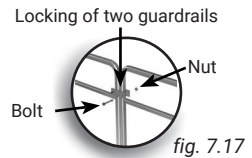
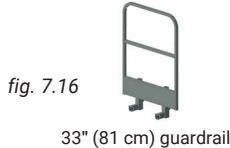
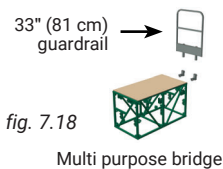

Plank-End Guardrail

Plank-end guardrails must be installed at the ends of planking as fall protection. In a three-plank configuration, the opening must be closed by placing two plank-end guardrails **face to face**.

- 1- Slide the bottom end of the plank-end guardrail over the end of two planks.
- 2- Drive one or two nails or screws into the planks through the top plate to secure the guardrail in place.
- 3- A three-plank configuration will require the installation of two plank-end guardrails. Follow steps 1 and 2 to install the first plank-end guardrail.
- 4- Slide a second plank-end guardrail backwards over the end of two planks, overlapping the first one installed. Secure the second guardrail in place as described in step 2.



Accessories

Guardrails

Face Guardrail Supports (optional)

Face guardrail supports must be installed when the distance between the end of planking (or deck, if not using planks) and the structure is greater than what local regulations allow (ex. recess in a wall, end of a building, etc.).

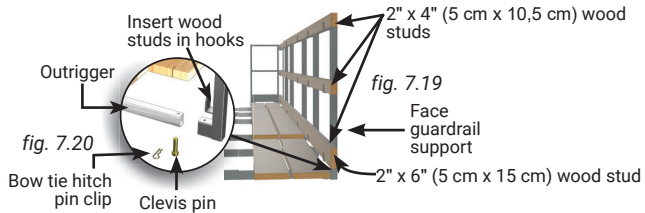

Installation

- 1- Remove the plank stop pin from the outrigger and slide the face guardrail support over the outrigger tube.
- 2- Slide a clevis pin through the face guardrail support and the outrigger. Secure the support in place with a bow tie hitch pin clip.
- 3- Repeat steps 1 and 2 for each guardrail face support required to secure the hazardous opening.
- 4- Insert wood studs in the hooks of each face guardrail support to cover the hazardous opening. It is important to make sure to use 2" x 6" (5 cm x 15 cm) wood studs at the bottom position. Secure the studs in place with nails or screws.
- 5- Tighten all the outrigger pocket bolts with a torque of 30 lb-ft (41 N-m).

Universal Plank Safety Support (optional)

The universal plank safety support is installed at the extremities of planking to prevent planks from lifting, tipping and slipping.

Installation

- 1- Lift and hold the stop pin (fig. 7.21) and slide the plank safety support between two planks.
- 2- Secure the C-shaped bracket around the outrigger and release the stop pin.
- 3- Using screws or nails, secure the top plate of the plank safety support to the planks (fig. 7.22).

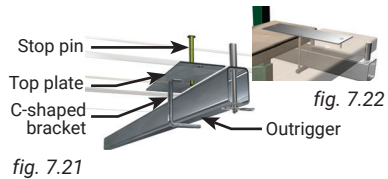

Movable Guardrail (optional)

To ensure the safety of workers in a more flexible way, movable guardrails may be installed on bridges. Follow the installation steps of a standard guardrail and secure the movable guardrail to the standard guardrail with toggle pins.

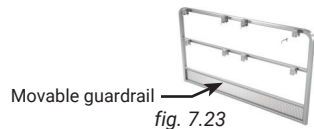

Accessories

Retractable Rest Platform
(optional)

The use of an automatically retractable rest platform is recommended to reach work areas at heights between 30' and 69' (9 m and 21 m). It is not recommended to climb up the mast to reach work areas at heights over 69' (21 m) because of the time and effort required to reach such heights. The use of alternate equipment compliant with local regulations, such as a rapid mast climber, a transport platform system, or a conventional scaffold stair system will prove to be more efficient. Refer to local regulations for more information.

It is recommended to inspect the rest platform before every working shift to make sure it is clean and in good working condition.

Installation

For safety reasons, it is recommended that the rest platform be installed from the platform of the motorized unit or from a man basket underneath the motorized unit. The rest platform must be installed on the right side of the mast, when the platform of the motorized unit has been raised to more than 30' (9 m) from base level.

- 1- Remove the 3/8" nuts and bolts from the folder part (fig. 7.26).
- 2- Unfold the rest platform and leave the handle on top.
- 3- Slide the rest platform inside the mast with its rectangular step resting against the right side of the mast (fig. 7.25).
- 4- Using 3/8" bolts and nuts, install the folder part on a rung on the left side of the mast.
- 5- Let the rest platform retract slowly inside the mast.
- 6- Remove the 3/8" bolt and nut from the handle.
- 7- Install the handle 5 rungs above the rest platform (fig. 7.27). Fasten with the 3/8" bolt and nut.
- 8- Test the rest platform by raising the handle. Doing so will retrieve the rest platform from inside the mast. When the handle is released the rest platform will fold and retract inside the mast.
- 9- If the rest platform unfolds and retracts as and when it should, it is safe to use the rest platform.

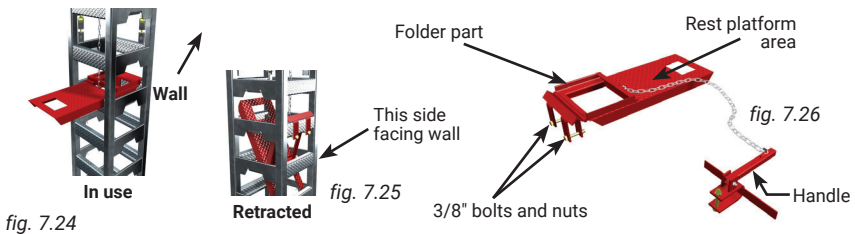

Using the retractable rest platform

- 1- Climb up the mast until one step above the rest platform.
- 2- Raise the handle to a vertical position to retrieve the rest platform from inside the mast.
- 3- Step on the rest platform only when the handle is in a vertical position.
- 4- Once on the rest platform, release the handle.
- 5- Resuming the climb up the mast will make the rest platform retract into the mast automatically.

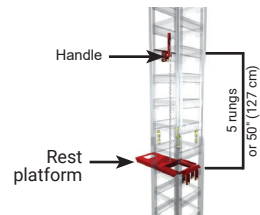

fig. 7.27



NOTICE

A rest platform can only be used on the mast of a P Series motorized unit with an access bridge installed.

Accessories

Access Bridge (optional)

To reach the work area when the motorized unit is at a height above 10' (3 m), it is recommended to use a staircase or an opening in the building. The platform may also be accessed by climbing up mast rungs to an optional access bridge, then up the ladder of that access bridge onto the work area (fig. 7.28). The access bridge must be installed **directly on the motorized unit**, on the **right side** of the mast only.

The access bridge can be used to reach work areas at heights of up to 69' (21 m) but requires the use of a retractable rest platform when the height of lift is over 30' (9 m). For more information about the retractable rest platform, see p. 87 of this section. It is not recommended to climb up the mast to reach work areas at heights over 69' (21 m) because of the time and effort required to reach such heights. The use of alternate equipment compliant with local regulations, such as a rapid mast climber, a transport platform system, or a conventional scaffold stair system will prove to be more efficient. Refer to local regulations for more information.

Installation

- 1- To install the access bridge, raise the motorized unit by two or three rungs.
- 2- Using a lifting device such as a crane or a forklift, lift and bolt the access bridge assembly on the **right side** of the motorized unit. Refer to p. 51 of the *Bridges* section for more information about the installation of a bridge.
- 3- Loosen the 3/8" bolts to pull out all three access walkway legs (fig. 7.28). Secure in place by tightening the bolts.
- 4- Lower the motorized unit carefully until the access walkway legs touch the bearing surface.
- 5- Remove the two locking bars at the bottom of the bridge assembly and slide them into their storage location (fig. 7.30).
- 6- Raise the motorized unit to completely unfold the access walkway and the flip up access step. The access ladder must only be used when it is **fully extended**. Once it is fully extended, the access walkway can be accessed by climbing up the mast rungs, stepping on the flip-up access step and then on the walkway. Climb up the access ladder and reach the work platform through the access panel. Make sure the access panel is closed when it is not used.

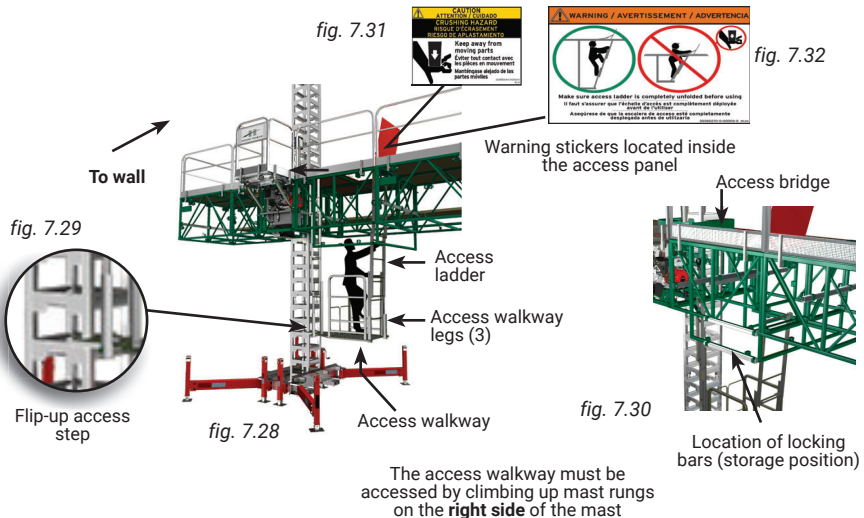

CAUTION
 The access bridge must be installed **directly on the motorized unit**, on the **right side** of the mast **ONLY** and cannot be positioned on the same side as a bearing bridge structure.

CAUTION
 It is important to note that the installation of an access bridge reduces the load capacity of the area where it is located.

Accessories

Access Stairs (optional)

When the motorized unit is at base level, workers may use the optional access stairs to reach the platform. The access stairs can be installed **on a bridge** in the setup but **not on the motorized unit**.

Installation

- 1- Install the door guardrail by sliding the guardrail legs in the guardrail pockets on the bridge. Secure the door guardrail with two toggle pins.
- 2- Slide the top part of the stairs into the top outrigger pockets (fig. 7.34).
- 3- Unfold the stair brace.
- 4- Secure the stair brace to the bottom truss of the bridge (fig. 7.33) with two toggle pins.
- 5- Secure the top part in place by sliding in two toggle pins and tightening each outrigger pocket bolt.
- 6- Install the handrails (2) and secure in place and tighten the bolts.
- 7- If the height between the bearing surface and the first step is greater than what is allowed by local regulations, it is mandatory to install one or more optional extension stairs (fig. 7.33). A **maximum** of three (3) extension stairs is allowed per access stairs installation.

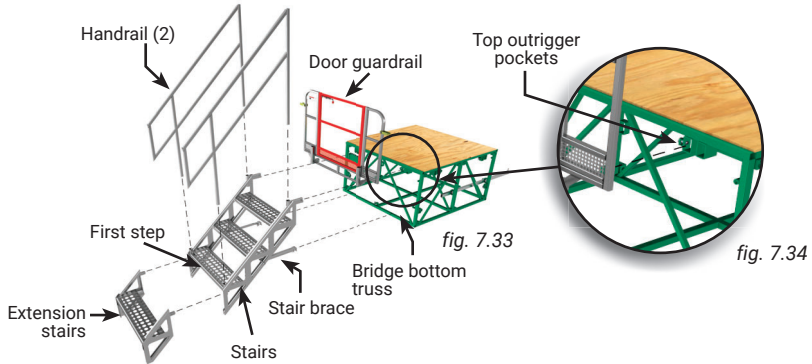

CAUTION

It is important to note that the installation of an access stairs reduces the load capacity of the area where it is located.

Bridge Installation Support Brackets

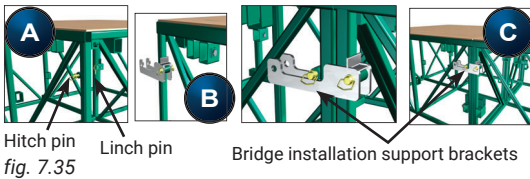

Hitch pin
fig. 7.35

Lynch pin

Bridge installation support brackets

The use of the bridge installation support brackets requires that at least two persons handle the bridge installation maneuvers. Bridge installation support brackets are used whenever a bridge must be lifted by hand and no appropriate lifting device is available.

Bridge installation support brackets must not be used to install a 10' (3 m) bridge nor a bridge to be bolted directly on the motorized unit.

Step A: Under the bridge to be installed, slide hitch pins in the designated holes on both sides of the bridge and secure them with lynch pins.

Step B: Using other hitch pin and lynch pin assemblies, attach the bridge installation support brackets to the bridge already bolted to the motorized unit or the bridge.

Step C: Lift the bridge to be installed and lower it down so that the hitch pins are completely supported by the bridge installation support brackets. Assemble the bridges using the appropriate bolts and nuts. Remove the brackets when the bridges are bolted together.



NOTICE

Bridge installation support brackets must not be used to install a 10' (3 m) bridge nor a bridge to be bolted directly on the motorized unit.

Accessories

Outriggers

Outriggers can be installed on two levels on P Series motorized units and bridges, top and bottom. Plank support outriggers must be installed 5' (1,5 m) from one another and can be installed from the front or the back of the bridge or motorized unit.

Plank support outriggers are not designed to support the weight of material and each outrigger has a maximum capacity of 265 lb (120 kg). Standard 63" (160 cm) outriggers, used either at the top or bottom position, can be pulled out to a maximum of 30" (76 cm).

The length of outriggers required will vary according to the planking configuration. Refer to the *Outrigger Selection* table (fig. 7.40) for more information about the length of outriggers required for each planking configuration.

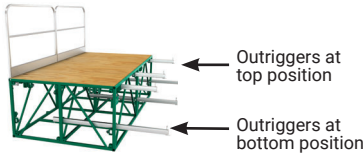

fig. 7.36

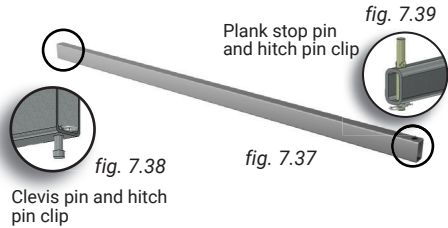

fig. 7.38

fig. 7.37

- 1- Remove the clevis pin and the plank stop pin (fig. 7.37) and slide the outrigger in the top outrigger pockets on the motorized unit or the bridge, leaving no more than 20" (50,8 cm) protruding from the structure if bottom outriggers are installed, or no more than 31" (78,7 cm) if there are no bottom outriggers installed. Replace the clevis pin and the plank stop pin on each outrigger.
- 2- Once the planks are in place, push in each outrigger until the plank stop pin rests snugly against the planks.
- 3- Secure the outriggers in place by tightening the outrigger pocket bolts with a torque of 30 lb-ft (41 N-m).

Planking configurations

Outrigger Selection		
Planking configuration	Outrigger size	
0 to 3 planks	2 1/2" x 1 1/2" x 1/8" x 63" (6,4 cm x 3,8 cm x 0,3 cm x 160 cm) (standard outrigger, as provided with unit or bridge)	SINGLE
4 planks	2 1/2" x 1 1/2" x 3/16" x 72" (6,4 cm x 3,8 cm x 0,5 cm x 183 cm)	SINGLE
5 planks	2 1/2" x 1 1/2" x 1/4" x 84" (6,4 cm x 3,8 cm x 0,6 cm x 213 cm)	SINGLE

fig. 7.40



NOTICE

It is important to note that four and five-plank configurations are non standard configurations. The pre-installation of all required mast sections and tie levels to reach the total mast height specified in the layout plan is **mandatory** for non standard configurations.

Planking configuration guidelines

fig. 7.41

PLANKING CONFIGURATIONS – WIDTH ALLOWED ON INSTALLATION			
Number of planks	Motorized unit	Bearing bridge	Cantilever bridge(s)
0 to 3 planks	100% of total width	100% of total width	100% of total width
4 or 5 planks	100% of total width	50% of total width	Max width 5' (1,5 m)



WARNING

Exceeding the specified planking configurations could result in serious injury or death.





Accessories

Outriggers

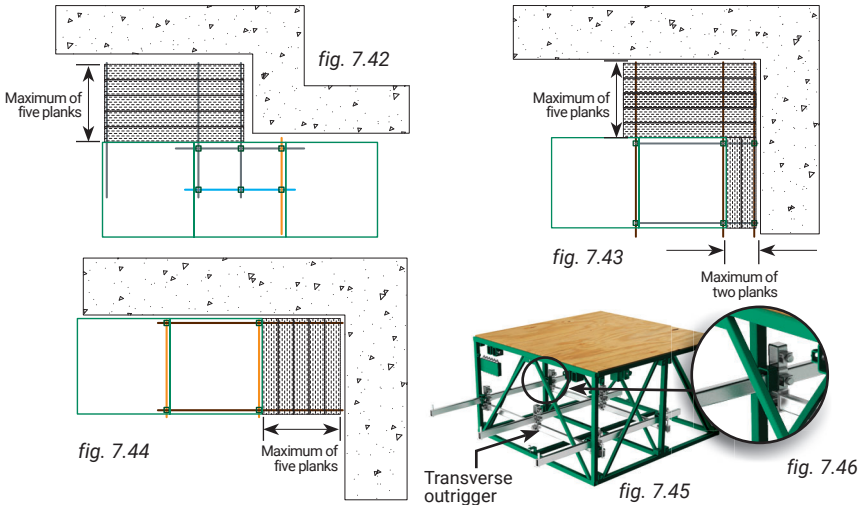
Non standard planking configurations allowed

Special planking configurations may be required according to job site requirements, to install planking in areas not covered by standard planking. The maximum number of planks for non standard planking configurations is 5 planks and **only the following three non standard planking configurations are allowed**. The following planking configurations will require the use of optional cross boxes and, in some cases, optional 120" (305 cm) outriggers. It is mandatory to install the cross boxes as close to the bridge outrigger pockets as possible (fig. 7.46).



LEGEND	
	2 1/2" x 1 1/2" x 1/8" x 63" (6,4 cm x 3,8 cm x 0,3 cm x 160 cm) (standard outrigger, as provided with unit or bridge)
	2 1/2" x 1 1/2" x 3/16" x 72" (6,4 cm x 3,8 cm x 0,5 cm x 183 cm)
	2 1/2" x 1 1/2" x 1/4" x 84" (6,4 cm x 3,8 cm x 0,6 cm x 213 cm)
	2 1/2" x 1 1/2" x 1/4" x 120" (6,4 cm x 3,8 cm x 0,6 cm x 305 cm)
	Cross box

Cross Boxes
(optional)

Cross boxes are used to install auxiliary outriggers, as required for non standard planking configurations.

Installation

- 1- Remove the clevis pin and the plank stop pin from an outrigger. Pull the outrigger until it clears the outrigger pocket located in the middle of the bridge structure.
- 2- Slide a cross box on the back of the outrigger. Push the outrigger back into the middle outrigger pocket. Slide another cross box on the back of the outrigger. Make sure both cross boxes are as close to the front and middle outrigger pockets as possible (fig. 7.46). Do not tighten any bolts yet.
- 3- Repeat steps 1 and 2 at the other end of the bridge.
- 4- Slide a transverse outrigger in the cross boxes installed close to the front outrigger pockets until the outrigger clears one of the pockets. Slide a cross box on the transverse outrigger until it is halfway through on the outrigger. Pull back the outrigger until it goes through both cross boxes installed close to the front outrigger pockets.

Accessories

Cross Boxes
(optional)

Installation (cont'd)

- 5- Repeat step 4 on the cross boxes installed close to the middle outrigger pockets.
- 6- Slide an outrigger in the cross boxes installed in the middle, between the left and right outrigger pockets.
- 7- Once the planks are in place, adjust the outriggers until the plank stop pins rest snugly against the planks.
- 8- Secure the outriggers in place by tightening all the bolts on outrigger pockets and cross boxes with a torque of 30 lb-ft (41 N-m).

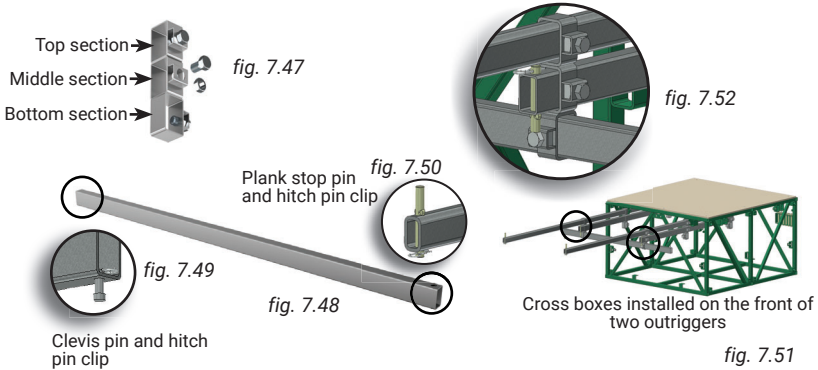
Auxiliary Electric Power Pack Bridge
(optional)

General guidelines

The optional auxiliary electric power pack bridge allows the conversion of a gas-powered P Series motorized unit into an electric-powered motorized unit. The optional power pack bridge can only be used in a standard configuration. For more information about standard configurations, refer to p. 19 of the *Motorized Unit* section.

- 1- Make sure that the motorized unit has been installed following the installation guidelines described in the *Motorized Unit* section, on p. 18, and that it can be operated safely.
- 2- Make sure to select a safe, reliable power source and a power cable that is suitable for the height of the setup. Refer to the *Power Cable Selection* table (fig. 7.54, p. 93) to select the appropriate power cable for the installation. Contact the Hydro Mobile technical support if a cable longer than 500' (152 m) is required.
- 3- Install the auxiliary electric power pack bridge as described in the installation instructions, on p. 94.
- 4- Install and hook up the power cable to the motorized unit and the power source. **The installation and hookup of the power cable must be performed by a certified electrician.**

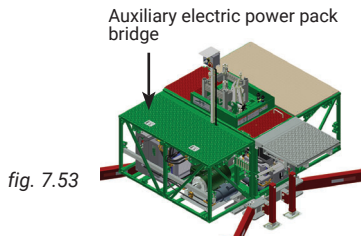

Accessories

Auxiliary Electric Power Pack Bridge
(optional)

Specifications of the Auxiliary Electric Power Pack Bridge

fig. 7.54

Power Cable Selection	
Length of cable	Cable size
Up to 200' (61 m)	10 AWG
201' to 300' (61,3 m to 91,4 m)	8 AWG
301' to 500' (91,7 m to 152 m)	6 AWG

fig. 7.55

Hydraulic Specifications	
Component	Specifications
Single gear pump	1 x 7,38 GPM (27,9 l/min)
Hydraulic tank capacity	8.3 US gal (31,42 l)
Hydraulic oil	Dexron III ATF
Oil filter	Ikron filter model HE K44-20-135-A5-SP010 (HM part number A0410000-0004)

Specific Features	
Weight (as shipped)	1000 lb (454 kg) (fully assembled)
Vertical travel speed	Up to 7' (2,1 m) per minute

fig. 7.56

fig. 7.57

General Specifications		
Dimensions of the auxiliary electric power pack bridge (as shipped)		30 1/2" x 62" x 49 11/16" (W x L x H) (0,8 m x 1,6 m x 1,3 m) (fully assembled)
Safety device – Emergency	Emergency descent	Independent electrical descent control system (120 VAC 60 Hz 15 A)

Motor Specifications		
	600 V model	480 V model
Rated power	10 HP @ 3600 rpm	10 HP @ 3600 rpm
Electrical input	600V 60 Hz 3 ph 20 A ±5%	480V 60 Hz 3 ph 20 A ±5%
Full load current draw	11 A	14 A
Control voltage	12 VDC	12 VDC

fig. 7.58

General guidelines (cont'd)

- 5- It is important to consider that the electric power pack bridge weighs 750 lb (340 kg) more than a regular 30" (76 cm) and that this weight difference must be deducted from the load capacities of the area where the auxiliary electric power pack bridge is installed. Refer to the *Load Capacities* section on p. 73 for more information about the loads allowed on a setup. Refer to step 9 of the installation instructions of the power pack bridge for the appropriate location where to install the power pack bridge in a setup.

**WARNING**

Installation of the power cable must be performed by a **certified electrician**.

Accessories

Auxiliary Electric Power Pack Bridge
(optional)

Overview of the Auxiliary Electric Power Pack Bridge

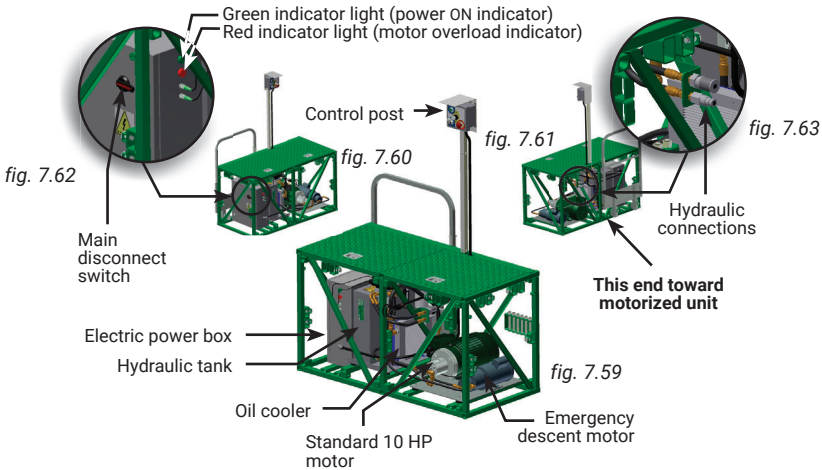

Installation of the auxiliary electric power pack bridge

- 1- Make sure to release any residual pressure in the hydraulic system of the motorized unit.
- 2- Carefully disconnect the two hydraulic hoses from the lifting cylinder of the unit, making sure to avoid spills. Cap the two hoses with the supplied hydraulic caps and secure the hoses inside the motorized unit.
- 3- Retrieve the hydraulic hose with a female quick connect fitting supplied with the electric power pack. Connect one end to the cylinder port located toward the mast on the motorized unit.
- 4- Retrieve the hydraulic hose with a male quick connect fitting supplied with the electric power pack. Connect one end of the hose to the cylinder port located away from the mast on the motorized unit.
- 5- Disconnect and remove the battery from the motorized unit.
- 6- Disconnect the spark plug wire to prevent unintentional use of the gasoline engine.
- 7- If the motorized unit will be used indoors or in an enclosed area, it is recommended to completely drain or remove the gasoline tank from the motorized unit to avoid fire hazards.
- 8- Store the control post on the motorized unit. For instructions on the storage of the control post, refer to p. 109 of the *Transport, Storage and Maintenance* section.
- 9- Bolt the auxiliary electric power pack bridge to the motorized unit, with the control post toward the unit, as shown in fig. 7.61. In a standard, **single unit** configuration, the bridge can be installed on either side of the mast. In a standard **twin units** configuration, the bridge **must be attached on the cantilever side** of the installation.
- 10- Connect the hydraulic hoses installed in steps 3 and 4 to the corresponding ports (female and male) on the electric power pack.
- 11- Release the spring latch and pull out the control post. Secure the control post in place with the spring latch.
- 12- If the motorized unit is used in a **twin units** configuration, make sure that the inclinometer has been connected to the appropriate port on the electric power box.



If the motorized unit will be used indoors or in an enclosed area, it is recommended to completely drain or remove the gasoline tank from the motorized unit to avoid fire hazards.

Accessories

Auxiliary Electric Power Pack Bridge (optional)

Installation and connection of the power cable

- 1- Select a power cable that is suitable for the height of the setup. Refer to the *Power Cable Selection* table (fig. 7.54, p. 93) for help with the selection of the power cable. Make sure that the overall length of the cable is sufficient for the installation (height of mast, distance from power source, acceptable overall slack in cable).
- 2- Run the power cable through the first bridge of the setup. The cable must clear the base completely.
- 3- Using a U bolt and flat bar assembly, attach an open mesh grip at the bottom of a vertical tube on the bridge (fig. 7.65).

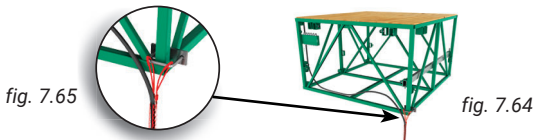

Note: Open mesh cable grip shown in red for illustration purposes only

- 4- Connect the power cable to a safe and reliable source (from the building or a generator). **This installation must be performed by a certified electrician.** Make sure that the input voltage is within the specified range and that phases are synchronized. Refer to p. 93 for more information on the input power range.

Auxiliary electric power pack startup procedure

- 1- Turn on the main disconnect switch located on the electric power box. The green indicator light on the power box will light up. If the red indicator light is lit, the motor overload is tripped. Turn off the main disconnect switch and contact a certified electrician to troubleshoot the problem.
- 2- Turn the ignition key to the START position, then release it to the ON position.

Auxiliary electric power pack shutdown procedure

- 1- Bring the motorized unit to the desired work level or down to base level.
- 2- Turn the ignition key to the OFF position.

Removing the auxiliary electric power pack bridge

- 1- Follow the dismantling guidelines appropriate for the installation. Refer to p. 36 of the *Motorized Unit* section for more information on dismantling an installation.
- 2- Make sure the motorized unit is at base level.
- 3- Turn the ignition key to the OFF position.
- 4- Turn off the main disconnect switch located on the electric power box. The green indicator light will turn off.
- 5- Disconnect the power cable. **This must be performed by a certified electrician.**
- 6- Pull the spring latch and store the control post. Secure the control post in its storage location with the spring latch.
- 7- Carefully disconnect the hydraulic hoses of the auxiliary electric power pack bridge from the motorized unit, making sure to avoid spills. Cap and store the two hydraulic hoses properly.
- 8- Remove the auxiliary electric power pack bridge.
- 9- Store the power pack bridge properly.

Restoring connections on the motorized unit

- 1- Replace and reconnect the battery on the motorized unit.
- 2- Reconnect the spark plug wire.
- 3- Carefully reconnect the two hydraulic hoses of the lifting cylinder, making sure to avoid spills.

Accessories

Freestanding Base
(optional)

The optional freestanding base is used to increase to 35' (11 m) the freestanding height allowed for a P Series setup.



CAUTION

A freestanding P Series installation must only be used in a standard single unit configuration. For more information about standard configurations, refer to p. 21 of the *Motorized Unit* section.

Installation of the freestanding base

- 1- Installation must be carried out by qualified erectors/dismantlers under the supervision of a competent person, in accordance with all applicable local regulations. For the definition of a qualified erector/dismantler, refer to p. 7 of the *Performance and Safety Rules* section.
- 2- In reference to the plan/layout drawing, make sure that all the components required are available. Establish the position of the freestanding base, determine if there are obstacles and what are the cribbing requirements.
- 3- Before installing the freestanding base, determine where the cribbing under the base and jacks will rest (see fig. 7.66). Use the *Authorized Height Using a Freestanding Base* table on p. 97 of this section as a guide to determine the appropriate extension of the base outriggers and the location of cribbing.

The bearing surface under the cribbing must be level, clear of debris and have the proper bearing capacity (see the *Minimum Bearing Surface Capacities* table, fig. 7.67). Should the actual bearing capacity be inferior to the values in the table, please seek instructions and recommendations from the distributor/service center. It is important to note that **the jacks on the freestanding base are designed to level the motorized unit and must not be used to support the load nor the motorized unit.**

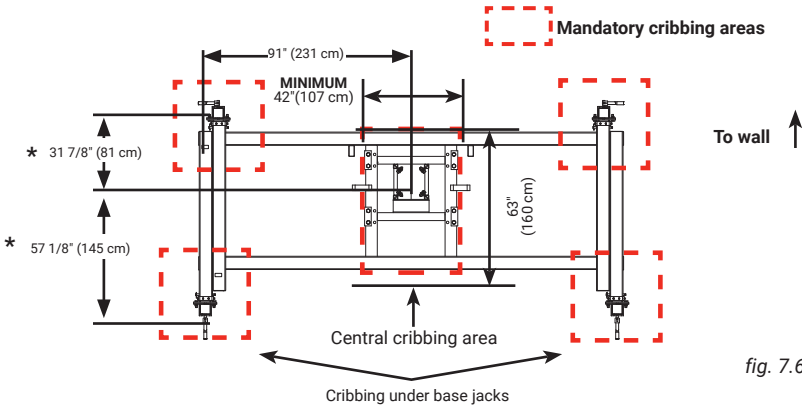

fig. 7.66

* Distances will vary according to the length of base outrigger extension required for the installation. Refer to the *Authorized Height Using a Freestanding Base* table, on p. 97 of this section.

fig. 7.67

Minimum Bearing Surface Capacities Installation with a Freestanding Adapter Base			
Height		Load on each outrigger jack (4)	Load under mast
(ft)	(m)	Reaction	Reaction *
35	10.7	3500 lb	15 560 lb
		1588 kg	7059 kg

* Load reactions in this column include a dynamic factor

Accessories

Freestanding Base
(optional)

Installation of the motorized unit on the freestanding base

- 1- Make sure that the freestanding base is installed properly, as described in the installation instructions on the previous page.
- 2- Make sure that there is one mast section installed on the motorized unit in addition to the mast section welded on the base.
- 3- Prepare the lifting and moving of the motorized unit as described in steps 1 through 5 of the preparation guidelines on p. 110 of the *Transport, Storage and Maintenance* section.
- 4- Raise the motorized unit up to the second mast section until it is above the mast bolts.
- 5- Secure a sling to the top first lifting rung at the back of the top mast section and hold the unit with a crane or a rough terrain forklift.
- 6- Loosen and flip down the mast bolts joining the second mast section to the mast section welded on the base of the motorized unit.
- 7- Lift the motorized unit following the guidelines on p. 111 of the *Transport, Storage and Maintenance* section for the lifting and moving of the unit with a sling.
- 8- Carefully lower the motorized unit on top of the freestanding base.
- 9- Secure the motorized unit to the freestanding base with the mast bolts located on the freestanding base. Tighten all mast bolts to 120 lb-ft (163 N-m) of torque, using a cross-pattern sequence when tightening.
- 10- Proceed with the installation of the unit by following the instructions for a standard, freestanding single unit configuration starting on p. 21 of the *Motorized Unit* section. Make sure that the outriggers on the adapter base are extended according to the height of the setup, as is required and allowed. Use the *Authorized Height Using a Freestanding Base* table (fig. 7.70) as a guide for the appropriate extension of the outriggers.

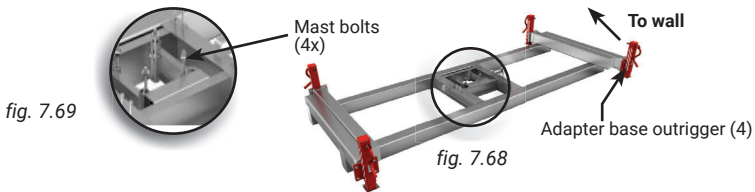

fig. 7.70

Authorized Height Using a Freestanding Base			
To wall →			
Ref	Length of base outrigger extension	Maximum height of mast	Maximum number of planks
A	10" (25 cm)	20' (9 m)	3
B	20" (51 cm)	30' (9 m)	3
C	30" (76 cm)	35' (11 m)	3



NOTICE

When using access stairs on a setup using a freestanding base, it is important to install an additional stair extension.

Accessories

Adapter Base for Sidewalk Canopy Installation
(optional)

The optional adapter base for sidewalk canopy installation is used to install a P Series motorized unit at 10' (3 m) above the bearing surface, as part of a sidewalk canopy installation. The optional adapter base for sidewalk canopy installation can be used in any single or twin units P Series configuration **with mast ties**. A P Series configuration using an adapter base for a sidewalk canopy installation must not be used on a mast with a height over 250' (76 m).

N **NOTICE**
It is important to note that the pre-installation of tie levels to the top of the mast is **mandatory** for a setup using an adapter base for sidewalk canopy installation is a non standard configuration.

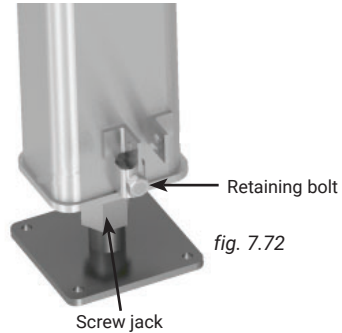
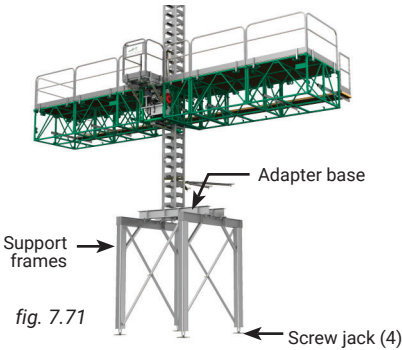

Installation of the adapter base

- 1- Before installing the adapter base, determine where the cribbing and the jacks will rest. Typically, for an installation without any planking, the support frame for the adapter base will be installed at 8" (20 cm) from the face of the wall.
- 2- The bearing surface under the support frames must be level, clear of debris and have a bearing capacity sufficient to support a load of 27,000 lb (12 247 kg) under each screw jack. When required, appropriate cribbing must be placed under each screw jack on the legs of the support frames to distribute the load. It is important to make sure that the bearing surface is stable and has not been subject to any type of erosion or deterioration caused by weather conditions (snow, rain, etc.).

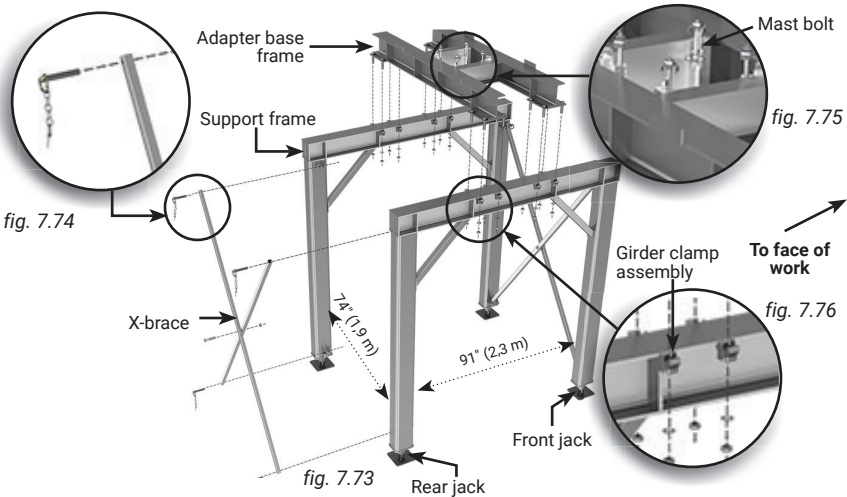

Accessories

Adapter Base for Sidewalk Canopy Installation
(optional)

Installation of the adapter base (cont'd)

- 3- Mark the position of jacks. The distance between the front and rear jacks is 91" (2,3 m), while the distance between the left and right jacks is 74" (1,9 m) (fig. 7.73, p. 98).
- 4- Using the supplied X-braces, assemble the two frames of the base support structure together. Verify that the assembly is square and make corrections, if necessary.
- 5- Loosen the retaining bolt on each leg of the frames (fig. 7.72, p. 98) to release the screw jacks.
- 6- Using a rough terrain forklift or a crane, lift and position the adapter base frame on top of the support assembly. Refer to the table in fig. 7.77 to determine the distance between the mounting flange on the adapter base and the front edge of the support assembly. The adapter base frame will be moved back by 10" to 12" (25 cm to 30 cm) from the front edge of the support assembly for each plank required by the configuration (as shown in fig. 7.77). If necessary, install the support assembly further back from the face of the wall to accommodate wider planking configuration (see step 1 and fig. 7.77). Use the *Outrigger Selection* table (p. 90) as a guide for planking configurations.
- 7- Secure the adapter base to the support assembly by tightening each girder clamp assembly (fig. 7.76, p. 98) with a torque of 108 lb-ft (147 N-m).
- 8- Verify the level of the adapter base and the support assembly. Adjust the level using the screw jacks on the support assembly or by adding cribbing.

Installation of the motorized unit

- 9- Make sure that there is no more than one 30" (76 cm) bridge installed on either side of the motorized unit.
- 10- Make sure that there is a mast section installed on the motorized unit in addition to the mast section welded on the base.
- 11- Prepare the lifting and moving of the motorized unit as described in steps 1 through 5 of the preparation guidelines on p. 110 of the *Transport, Storage and Maintenance* section.

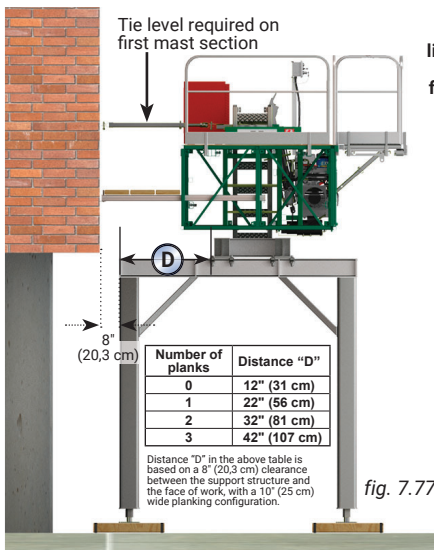

Unit must have a sling secured to the first lifting rung at the back of the top mast section and be held up by a crane or rough terrain forklift during installation until first tie level is installed



fig. 7.78

Unit on adapter base for sidewalk canopy installation with three-plank configuration



CAUTION

Once the unit is installed on the adapter base, it is **mandatory** to install a tie level on the **first** mast section before proceeding with the installation.

Accessories

Adapter Base for Sidewalk Canopy Installation
(optional)**Installation of the motorized unit (cont'd)**

- 12- Raise the motorized unit up to the second mast section until it is above the mast bolts of the mast section welded on the base.
- 13- Secure a sling to the top first lifting rung at the back of the top mast section and hold the unit with a crane or a rough terrain forklift.
- 14- Loosen and flip down the mast bolts joining the second mast section to the mast section welded on the base of the motorized unit.
- 15- Lift the motorized unit following the guidelines on p. 111 of the *Transport, Storage and Maintenance* section for the lifting and moving of the unit with a sling.
- 16- Carefully lower the motorized unit on top of the adapter base.
- 17- **Continue to hold the motorized unit** and secure it to the adapter base with the mast bolts located on the adapter base. Tighten all mast bolts with a torque of 120 lb-ft (163 N-m), using a cross-pattern sequence when tightening.
- 18- **Still holding the motorized unit**, tie the mast to the face of the work. Refer to p. 64 of the *Mast and Mast Ties* section and to the *Tie Level Installation Schedule* in fig. 7.79 below for instructions on how and when to install mast ties.
- 19- Once the first tie level is installed, make sure that the hooks are properly engaged on a mast rung and release the unit. Continue installing the setup as described in the general guidelines and installation instructions starting on p. 18 of the *Motorized Unit* section.

fig. 7.79

Tie Level Installation Schedule • Setups with Adapter Base for Sidewalk Canopy Installation	
Maximum travel distance above the last tie level	20' (6,1 m) (standard configurations only)
First tie level	On first mast section
Second tie level	No more than 10' (3 m) above first tie level
All subsequent: every	20' (6,1 m)
Maximum freestanding height allowed	Not allowed

Dismantling guidelines – single unit setup

The following dismantling steps can be used for a configuration using an adapter base for sidewalk canopy installation.

- 1- Make sure all the equipment necessary for a safe dismantlement of the installation is on hand (slings, crane or rough terrain forklift, etc.). **Make sure the regular motorized unit base is also on hand.**
- 2- Follow the dismantling instructions appropriate for the configuration **leaving the last two tie levels in place.** For dismantling instructions, refer to the *Motorized Unit* section, starting on p. 36.
- 3- Before lifting and moving the motorized unit, make sure all workers have stepped down and that all tools, equipment and loads have been removed from the platform.
- 4- Using a rough terrain forklift or a crane, support the motorized unit. Refer to p. 110 of the *Transport, Storage and Maintenance* section for instructions on the lifting of a motorized unit. Remove the last two tie levels. Make sure that the motorized unit remains on the second mast section, above the mast bolts joining it to the first mast section installed.
- 5- **Still holding the motorized unit**, loosen all mast bolts and clamps holding the unit to the adapter base.
- 6- To ensure proper stability, **make sure that the regular base is level and that all base outriggers are opened at a 30-degree angle.** Carefully lift the motorized unit off the sidewalk canopy frame and lower it on top of the regular base.
- 7- **Continue to hold the unit** and secure it to the base by tightening all bolts with a torque of 120 lb-ft (163 N-m), using a cross-pattern sequence when tightening.
- 8- Once the base is secured, make sure that hooks are properly engaged on a mast rung and release the motorized unit.
- 9- Remove the adapter base from the support assembly.
- 10- Remove the X-braces and disassemble the support assembly.
- 11- If the unit is to be stored for any significant length of time, refer to p. 110 of the *Transport, Storage and Maintenance* section for instructions on how to properly store a P Series motorized unit.

Accessories

Mast Base Plate
(optional)

The optional mast base plate is used to install a P Series motorized unit in areas where space is restricted around the base. The optional mast base plate can be used in any single or twin units P Series configuration **with mast ties**. A P Series installation using an optional mast base plate cannot be used on a mast with a height over 250' (76 m).



NOTICE

It is important to note that the pre-installation of all required mast sections and tie levels to reach the total mast height specified in the layout plan is **mandatory** for a setup using a mast base plate.

Installation

- 1- Before installing the mast base plate, determine where the cribbing will rest. The bearing surface under the cribbing must be level, clear of debris and have the proper bearing capacity. Refer to the *Minimum Bearing Surface Capacities for an Installation with a Mast Base Plate* table (fig. 7.83, p. 102) for guidance. Contact a licensed engineer for assistance.
- 2- Make sure that there is no more than one 30" (76 cm) bridge installed on either side of the motorized unit.
- 3- Make sure that there is a mast section installed on the motorized unit in addition to the mast section welded on the base.
- 4- Before lifting and moving the motorized unit, make sure all workers have stepped down, that all tools, equipment and loads have been removed from the platform.
- 5- Prepare the lifting and moving of the motorized unit as described in steps 1 through 5 of the preparation guidelines on p. 110 of the *Transport, Storage and Maintenance* section.
- 6- Raise the motorized unit up to the second mast section until it is above the mast bolts of the mast section welded on the base.
- 7- Secure a sling to the top first lifting rung at the back of the top mast section and hold the unit with a crane or a rough terrain forklift. Loosen and flip down the mast bolts joining the second mast section to the mast section welded on the base of the motorized unit.



fig. 7.80

Unit must have a sling secured to the top first lifting rung located at the back of the top mast section and be held up by a crane or a rough terrain forklift during installation until the first two tie levels are installed

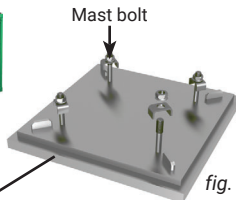

fig. 7.81

Mast base plate



fig. 7.82

- 8- Lift and carefully lower the motorized unit on top of the mast base plate.
- 9- **Continue to hold the motorized unit** and secure it to the mast base plate with the mast bolts located on the mast base plate. Tighten all mast bolts to 120 lb-ft (163 N-m) of torque, using a cross-pattern sequence when tightening.
- 10- **Still holding the motorized unit**, tie the mast to the face of the work. The first tie must be installed at not more than 5' (1,5 m) from the bearing surface. Refer to p. 64 of the *Mast and Mast Ties* section for instructions on how to install mast ties. Refer to the *Tie Level Installation Schedule* (fig. 7.84, p. 102) for the installation of subsequent tie levels.



CAUTION

The **jacks on the base outriggers** are designed to level and stabilize the motorized unit and **must be opened completely** before the start of **dismantling** operations.

On an installation where the unit is not on its regular base and is on an adapter base or a mast base plate, it is **mandatory to hold the motorized unit** using a sling and crane or a rough terrain forklift **before removing the last two tie levels**.

Accessories

Mast Base Plate
(optional)

Installation (cont'd)

- 11- Once the **first two tie levels are installed**, make sure that the hooks are properly engaged on a mast rung and release the unit. Proceed with the installation of the setup as described in the general guidelines and installation instructions for a standard setup with mast ties starting on p. 18 of the *Motorized Unit* section.

fig. 7.83

Minimum Bearing Surface Capacities Installation with a Mast Base Plate (for static loads)		
Height		Load under mast
(ft)	(m)	Reaction (for static load)
20	6,1	13,059 lb
		5923 kg
50	15,2	14,657 lb
		6648 kg
75	22,9	15,925 lb
		7223 kg
100	30,5	17,194 lb
		7799 kg
200	61,0	22,269 lb
		10,101 kg
250	76,2	24,807 lb
		11,252 kg

fig. 7.84

Tie Level Installation Schedule Installation with a Mast Base Plate	
Maximum travel distance above the last tie level	20' (6,1 m) (standard configurations only)
First set between	Base level and 5' (1,5 m and 1,5 m)
Second set between	5' and 10' (1,5 m and 3 m)
All subsequent: every	20' (6,1 m)
Maximum freestanding height allowed	Not allowed

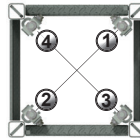

fig. 7.85

Cross pattern
sequence

Dismantling guidelines – single unit setup

The following dismantling steps can be used for a single unit P Series configuration using a mast base plate.

- 1- Make sure all the equipment necessary for a safe dismantlement of the installation is on hand (slings, crane or rough terrain forklift, etc.). **Make sure the regular motorized unit base is also on hand.**
- 2- Follow the dismantling instructions appropriate for the configuration **leaving the last two tie levels in place.** For dismantling instructions, refer to the *Motorized Unit* section, starting on p. 36.
- 3- Before lifting and moving the motorized unit, make sure all workers have stepped down and that all tools, equipment and loads have been removed from the platform.
- 4- Prepare the lifting and moving of the motorized unit as described in steps 1 through 5 of the preparation guidelines on p. 110 of the *Transport, Storage and Maintenance* section.
- 5- Secure a sling to the top first lifting rung at the back of the top mast section and hold the unit with a crane or a rough terrain forklift. Remove the last two tie levels.
- 6- **Still holding the motorized unit**, loosen all mast bolts and clamps holding the unit to the mast base plate.
- 7- To ensure proper stability, **make sure that the regular base is level and that all base outriggers are opened at a 30-degree angle.** Carefully lift the motorized unit off the mast base plate and lower it on top of the regular base.
- 8- **Continue to hold the unit** and secure it to the base by tightening all mast bolts with a torque of 120 lb-ft (163 N-m), using a cross-pattern sequence when tightening (fig. 7.85).
- 9- Once the base is secured, make sure the hooks are properly engaged on a mast rung and release the motorized unit.
- 10- If the unit is to be stored for any significant length of time, refer to p. 110 of the *Transport, Storage and Maintenance* section for instructions on how to properly store a P Series motorized unit.

Accessories

Multiple Mast Handler
(optional)

The use of the multiple mast handler will allow the qualified erector/dismantler to install or remove assembled lengths of mast (also referred to as “sticks”) and reduce the time required to achieve the installation or the dismantling of the setup.

General guidelines

- 1- The length of assembled mast allowed must be equal to the authorized length of mast in feet (meters) to reach the level at which to install or remove the next tie level, according to the tie level installation schedule specific to the installation.
- 2- For more information about distances between tie levels, refer to the *Tie Level Installation Schedule* table on p. 66 of the *Mast and Mast Ties* section.

Installation of assembled lengths of mast sections

- 1- Assemble a length of mast sections on the ground. Mast sections must be laid down horizontally on the ground. For instructions on the assembly of mast sections, refer to p. 63 of the *Mast and Mast Ties* section. Tighten all bolts with a torque of 120 lb-ft (163 N-m) using a cross pattern sequence.
- 2- Install the mast handler on the highest rung of the lowest mast section of the assembled length of mast (fig. 7.88).
- 3- It is important to consider the weight of the assembled length of mast that must be lifted and to make sure to select a sling, chain or cable that can lift that weight. For example, a 20' (6,1 m) length of assembled mast sections will weigh 940 lb (426 kg).
- 4- Insert the sling (or chain or cable) through the assembled length of mast and attach the hook to the shackle on the mast handler.
- 5- Using a crane (or a forklift), carefully lift and lower the assembled length of mast on top of the last mast section installed.
- 6- Still holding the length of mast, attach the bottom mast section to the top of the mast section already installed. Tighten all bolts with a torque of 120 lb-ft (163 N-m), using a cross pattern sequence.
- 7- Remove the shackle from the mast handler to release the hook and sling. Monitor the release of the sling to avoid potential interferences.
- 8- Remove the multiple mast handler from the mast section.
- 9- Raise the motorized unit on the newly added length of mast, making sure that mast bolts are tightened with a torque of 120 lb-ft (163 N-m).
- 10- Install the next tie level. For instructions on the installation of a tie level, refer to p. 64 of the *Mast and Mast Ties* section.
- 11- Repeat steps 1 to 10 for each assembled length of mast to install, as required and allowed.

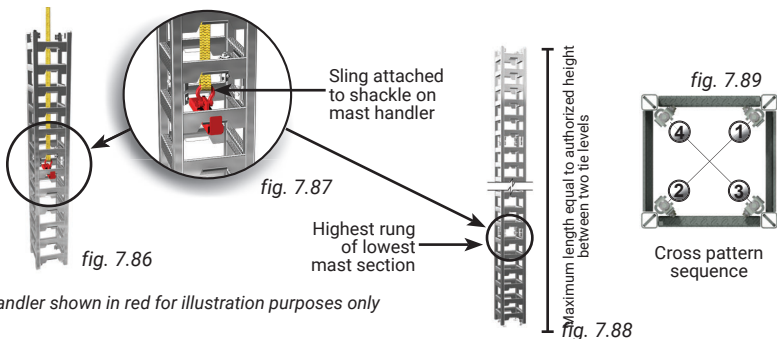

Removing assembled lengths of mast sections

- 1- Bring the motorized unit to where a tie level must be removed. Remove the tie level. For instructions on how to remove a tie level, refer to p. 67 of the *Mast and Mast Ties* section.
- 2- Lower the platform to the next lower tie level.

Accessories

Multiple Mast Handler (optional)

Removing assembled lengths of mast sections (cont'd)

- 3- Install the multiple mast handler on the highest rung of the bottom mast section of the assembled length of mast to remove (fig. 7.88, p. 103).
- 4- It is important to consider the weight of the assembled length of mast that must be lifted and to make sure to select a sling, chain or cable that can lift that weight. For example, a 20' (6,1 m) length of assembled mast sections will weigh 940 lb (426 kg).
- 5- Insert the sling (or chain or cable) through the assembled length of mast and attach the hook to the shackle on the mast handler.
- 6- Using a crane (or a forklift), hold the sling.
- 7- Loosen and remove all the mast bolts joining the lowest mast section of the assembled length to the mast section below. For instructions on the removal of mast sections, refer to p. 67 of the *Mast and Mast Ties* section.
- 8- Carefully lift the assembled length of mast and lower it down in a safe area, away from construction traffic.
- 9- Remove the multiple mast handler from the mast section.
- 10- Repeat steps 1 to 9 for each assembled length of mast to remove, as required and allowed.

Caster Wheels (optional)

The optional caster wheels are used to manually move a P Series motorized unit on a short distance to a different location. Preferably, caster wheels must be used on a **flat, even surface**. Using plywood as ground cover will help when moving a motorized unit on caster wheels on an uneven surface. It is not recommended to use caster wheels to move a P Series motorized unit on sloped ground.

The relocation of a P Series motorized unit must be carried out with extreme care.

Installation of the caster wheels

- 1- Before lifting the motorized unit, remove all the mast sections, leaving only one mast section in place. Make sure that all the guardrails and other components are secure.
- 2- Secure a sling to the top first lifting rung at the back of the top mast section and slightly lift the unit with a crane or a rough terrain forklift until it no longer touches the ground. Raise the jacks on the base and on the base outriggers **completely**.
- 3- Using bolt assemblies, install the caster wheels (4). Tighten all bolt assemblies properly.
- 4- Lower the motorized unit on the bearing surface carefully. The motorized unit is now ready to be moved.

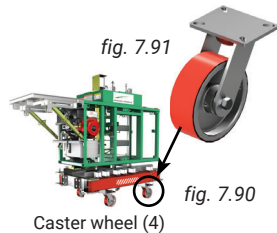

Relocation using the caster wheels

- 1- In reference to the plan/layout drawing, establish the position where the motorized unit must be moved to and make sure that there are no obstacles.
- 2- Make sure that the transport and destination areas are clear of workers and equipment or any obstacle liable to interfere with the operation.
- 3- Proceed with the installation of the motorized unit in its new location as described in the general guidelines and installation instructions, starting on p. 18 of the *Motorized Unit* section.



Using the optional caster wheels, the P Series motorized unit can be eased through a 36" (0,9 m) opening in side-to-side movements once the guardrails have all been removed.

Accessories

Hoist Support Assembly
(optional)

The optional hoist support assembly can be installed on a P Series bridge and is designed to be used with an electric hoist with a maximum lifting capacity of 1000 lb (454 kg) (lifting capacity based on a hoist weighing 250 lb or 113 kg).

N**NOTICE**

It is important to note that a setup using a hoist support assembly and a hoisting device (not sold by Hydro Mobile) is a non standard configuration. The pre-installation of all required mast sections and tie levels to reach the total mast height specified in the layout plan is **mandatory** for non standard configurations.

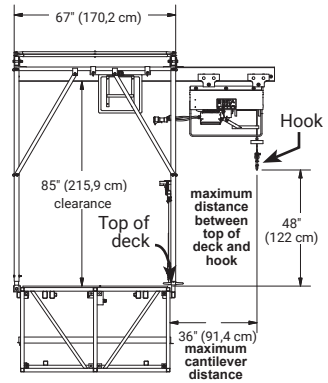
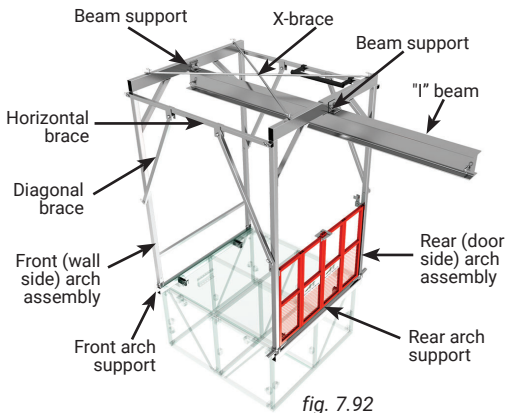

Note: The maximum distance between the deck and the hook shown in fig. 7.93 is based on the use of a Betamax Leo hoist.

Installation

- 1- The hoist support assembly must be installed on the first bridge closest to the motorized unit. Refer to p. 81 of the *Load Capacities* section for more information on the allowed location and load capacities of a setup equipped with a hoist and its support assembly.
- 2- Insert the rear arch support (fig. 7.92) into the outrigger pockets on the bridge. Do not tighten the outrigger pocket bolts completely at this point.
- 3- Insert the front arch support in the outrigger pockets on the bridge. Do not tighten the outrigger pocket bolts completely at this point.
- 4- Slide the rear arch assembly onto the threaded rods of the rear arch support.
- 5- Slide the front arch assembly onto the front arch support. Insert the pivot bolts into the forks to secure the arch in place. Make sure the locking bolts are in place.
- 6- Install the two horizontal braces on top of the mounting pins to link the front and rear arches together. Secure the braces to the arches with hitch pins.
- 7- Install the four diagonal braces to make the assembly more rigid. Secure the braces to the horizontal braces and to the arches with hitch pins.
- 8- Slide the I beam in the assembly and secure to the front and rear arches with bolt assemblies. Make sure to use a 9' (2,7 m) W6x9 beam.
- 9- Install the X-brace over the mounting pins on top of the assembly. Secure to the front and rear arches with hitch pins.
- 10- Make sure the assembly is plumb on all its axis, front and rear. Tighten all bolt assemblies with a torque of 60 lb-ft (81 N-m).
- 11- Install the electrical hoist (not supplied) as per the manufacturer's instructions.

**CAUTION**

Inspection and maintenance of the hoisting device must be performed as per the hoisting device manufacturer's recommendations.

Accessories

Weather Protection for Bridges
(optional)

Weather protection can increase work efficiency by protecting workers, material and equipment against adverse climatic conditions. A weather protection structure allows users to fasten tarpaulins quickly. The weight of the weather protection structure and its accessories must be deducted from the load capacities of the setup.

It is important to note that weather protection can only be installed on **standard configurations**. For more information about standard configurations, refer to p. 19 of the *Motorized Unit* section. It is **mandatory** to read and understand the safety guidelines before installing weather protection.

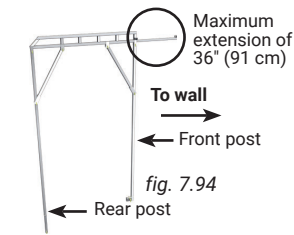

Weather protection support frame
Dead weight of 100 lb (45,4 kg)

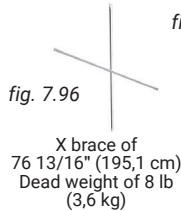
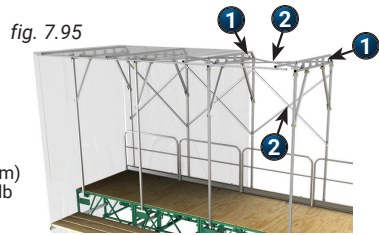

fig. 7.95



1 Weather protection support frame
2 X brace of 76 13/16" (195,1 cm)



NOTICE

It is important to note that a setup using weather protection is a non standard configuration. The pre-installation of all required mast sections and tie levels to reach the total mast height specified in the layout plan is **mandatory** for non standard configurations.

Safety guidelines

- 1- The use of weather protection is not allowed on a freestanding installation.
- 2- Weather protection is **allowed only on a standard configuration**.
- 3- An installation requiring the use of weather protection must be tied to the face of the work. In addition, tie levels must be installed all the way to the top of the installation before the start of any work. Traveling above the last tie point is not allowed in an installation equipped with weather protection.
- 4- The use of weather protection is not allowed when wind speeds exceed 28 mph (45 km/h).
- 5- **Weather protection must not be used when work is performed on an open air structure.**
- 6- **When out of service, a platform equipped with weather protection must be brought down to base level.**
- 7- Refer to p. 66 of the *Mast and Mast Ties* section for more information about the schedule for the installation of tie levels for a setup equipped with weather protection.



CAUTION

It is important to note that the installation of weather protection reduces the load capacity of the area where it is located.

Installation

- 1- Insert the front post of a support frame in the guardrail pocket of the bridge. Secure in place with a toggle pin and tighten the pocket bolt.
- 2- Insert the rear post of the support frame in the tube behind the guardrail on the other side of the bridge (fig. 7.94). Secure in place using a 3/8" x 3" GR5 bolt and nut assembly.
- 3- Repeat steps 1 and 2 to install a support frame on the following bridge.
- 4- Secure the two support frames by installing X-braces (fig. 7.96) on top and in the back of the structure.
- 5- Repeat steps 1 through 4 to install a support structure every 5' (1,5 m). In a cantilever configuration, the last frame installed will be on the 30" (76 cm) bridge attached to the unit.



CAUTION

It is important to keep a weather protection installation free from snow and ice accumulation.

Accessories

Monorail
(optional)

Using the same support structure as the weather protection system, the monorail system allows loads of up to 1000 lb (454 kg) to be moved safely along the installation. The monorail system can be used on setups with a maximum planking configuration of three planks wide.

It is important to note that only one monorail installation per motorized unit setup is allowed. The weight of the monorail structure and its accessories must be deducted from the load capacities of the setup. The loads allowed to be moved by the monorail system must be determined according to the load capacities of the area where the system is installed. Refer to the *Load Capacities* section on p. 73 to avoid overloading the platform.

N

NOTICE

It is important to note that a setup using a monorail system is a non standard configuration. The pre-installation of all required mast sections and tie levels to reach the total mast height specified in the layout plan is **mandatory** for non standard configurations.

Safety guidelines

- 1- The use of a monorail is allowed only in a standard configuration and is not allowed on a freestanding installation.
- 2- An installation requiring the use of a monorail must be tied to the face of the work. In addition, all required mast sections and tie levels to reach the total mast height specified in the layout plan must be installed before the start of any work. Traveling above the last tie point is not allowed in an installation equipped with a monorail.
- 3- Refer to p. 67 of the *Mast and Mast Ties* section for more information about wind speeds and to p. 66 for the schedule of installation of tie levels for a setup equipped with a monorail.

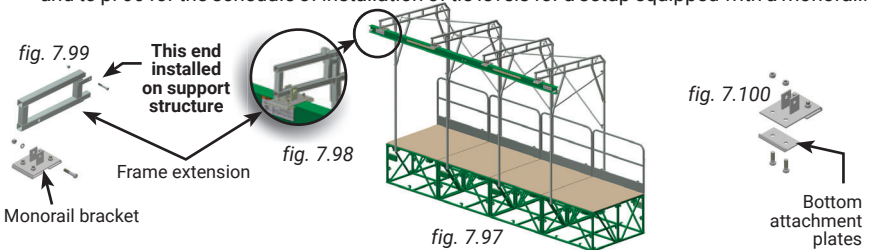

Installation

- 1- To install the monorail support structure, follow steps 1 through 5 of the installation instructions for the weather protection structure, on p. 106 of this section.
- 2- Insert the connecting tube of the frame extension in the bottom tube of the top part of the support structure. Secure in place with a bolt assembly.
- 3- Loosen all four bolts on a monorail bracket (fig. 7.100) to slacken the attachment plates on the bottom. Bolt the monorail bracket to the frame extension installed in step 2.
- 4- Repeat steps 2 and 3 for each monorail beam attachment assembly required by the installation (combination of a frame extension and a monorail bracket).
- 5- Once all monorail beam attachments are secure, slide the top of monorail beams between the attachment plates on the monorail brackets, using monorail beam plates to join beams together.
- 6- Secure the monorail beams in place by tightening the four bolts holding the attachment plates on each of the monorail brackets.
- 7- Make sure that the monorail beam does not overhang by more than 4' (1,2 m), as shown in fig. 7.101.
- 8- Slide the trolley on the monorail beam.

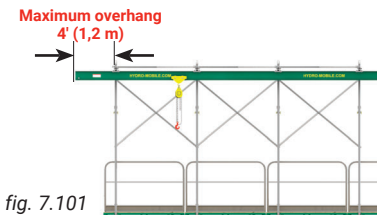

fig. 7.101

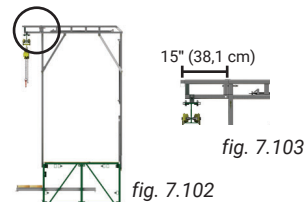

fig. 7.102

fig. 7.103

Maximum capacity of 1000 lb (454 kg)

Transport and Storage

Preparation of the motorized unit for transport

- 1- Follow the dismantling guidelines appropriate to the installation. Refer to p. 36 of the *Motorized Unit* section for more information on dismantling an installation.
- 2- Make sure the motorized unit is at base level and turn off the engine.
- 3- Make sure that all workers have stepped down and that all tools, equipment and loads have been removed from the platform.
- 4- Open the engine access panel and move the engine gasoline valve lever to the OFF position (fig. 8.1 and fig. 8.2). Close the engine access panel.

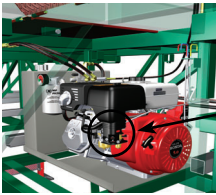
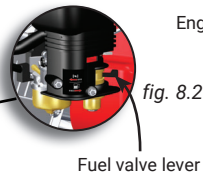

fig. 8.1



Fuel valve lever

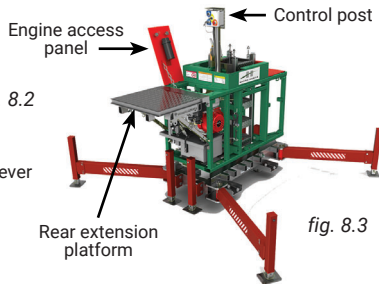
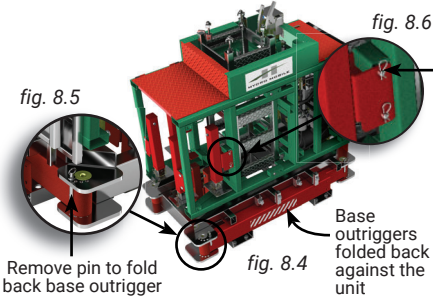

fig. 8.3

- 5- Store the control post. Refer to p. 109 of this section for instructions on how to store the control post.
- 6- Disconnect the battery.
- 7- Lower and secure the rear extension platform. For instructions on how to lower and secure the rear extension platform for transport and storage, refer to p. 17 of the *Motorized Unit* section.
- 8- Remove the jacks (4) on the base outriggers and store them in their storage area on the unit by securing them to the pockets provided with clevis pins and hitch pin clips (fig. 8.6).
- 9- Once all four jacks are removed and stored, remove the pin and fold back each base outriggers against the unit and secure in place with the pin.



Remove pin to fold back base outrigger

fig. 8.4

Base outriggers folded back against the unit

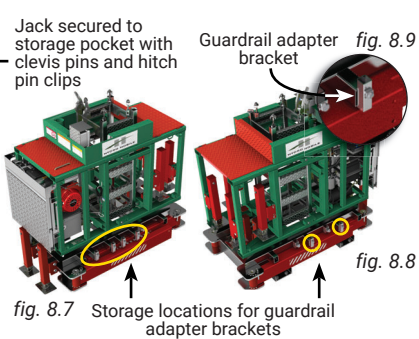

Jack secured to storage pocket with clevis pins and hitch pin clips

Guardrail adapter bracket

Storage locations for guardrail adapter brackets

- 10- Clean, store and secure all guardrails properly for transport. Refer to instructions on how to store the motorized unit guardrails further on in this section.

Storage of the motorized unit guardrails

- 1- Inspect the structure of each motorized unit guardrail, including the inside of the open-end tubes, for any sign of damage or distortion. Clean each guardrail thoroughly to limit the effects of any corrosive agent.
- 2- Remove the guardrail adapters of each 27" (69 cm) guardrail and store them in the lateral guardrail pockets on the unit, four on one side and two on the other (fig. 8.7 and fig. 8.8). Secure the guardrail adapters with toggle pins. Leave the guardrail adapters in place on both 60" (152 cm) guardrails.

Transport and Storage

Storage of the motorized unit guardrails (cont'd)

- 3- Insert each 27" (69 cm) guardrail in the guardrail adapters installed on the base (fig. 8.7 and fig. 8.8, p. 108). Tighten the bolt on each guardrail adapter to secure the guardrails in place.
- 4- Insert the guardrail adapters of each 60" (152 cm) guardrail in the storage tubes located on the base, as shown in fig. 8.11. Tighten the bolt on each guardrail adapter to secure the guardrails in place.

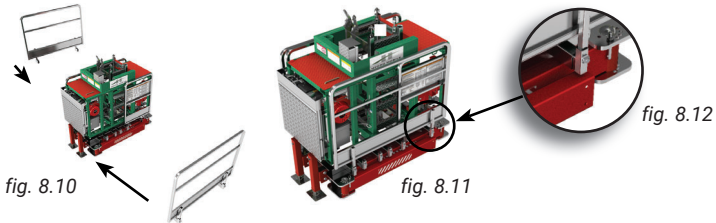

Storage of a standard guardrail

- 1- Inspect the structure of each guardrail, including the inside of the open-end tubes, for any sign of damage or distortion. Clean the guardrail thoroughly to limit the effects of any corrosive agent.
- 2- Store the guardrail on the bridge if the bridge is designed for it. Guardrails must not be stored directly on the ground. Make sure to place sufficient cribbing under the guardrails to prevent damages to the structure.
- 3- Avoid storing the guardrails in a location with direct exposure to aggressive or corrosive materials in the surroundings.

Storage of a bridge

- 1- Inspect the structure of the bridge, including the inside of the open-end tubes, for any sign of damage or distortion. Clean the bridge and its components thoroughly to limit the effects of any corrosive agent.
- 2- Bridges must not be stored directly on the ground. Make sure to place sufficient cribbing under the bottom chords to prevent damages to the bottom of the structure.
- 3- Avoid storing the bridge in a location with direct exposure to aggressive or corrosive materials in the surroundings.

Storage of a mast section

- 1- Inspect the structure of each mast section, including the inside of the open-end tubes, for any sign of damage or distortion. Clean each mast section and its components thoroughly to limit the effects of any corrosive agent.
- 2- Mast sections must be stored on a flat surface away from work areas and construction traffic, vertically or horizontally.
- 3- Avoid storing mast sections in a location with direct exposure to aggressive or corrosive materials in the surroundings.

Storage of the control post

- 1- Pull the spring latch (fig. 8.14), turn the control post by 180 degrees and slide it in until it is completely inside its storage location.
- 2- Make sure the spring latch is engaged and locks the control post in place.

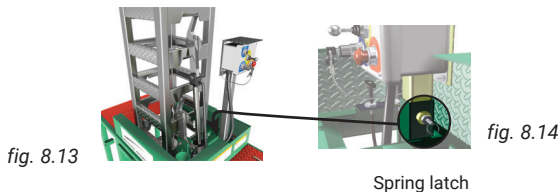

Spring latch

Transport and Storage

Storage of the access stairs

- 1- Inspect the structure of the access stairs, railings and extension(s), including the inside of the open-end tubes, for any sign of damage or distortion. Clean the access stairs, railings and extension(s) thoroughly to limit the effects of any corrosive agent.
- 2- Access stairs, railings and extensions must not be stored directly on the ground. Make sure to place sufficient cribbing under the access stairs to prevent damages to the bottom of the structure.
- 3- Avoid storing the access stairs in a location with direct exposure to aggressive or corrosive materials in the surroundings.

Storage of the access bridge

- 1- Inspect the structure of the access bridge and the ladder, including the inside of the open-end tubes, for any sign of damage or distortion. Clean the access bridge and the ladder thoroughly to limit the effects of any corrosive agent.
- 2- An access bridge must not be stored directly on the ground. Make sure to place sufficient cribbing under the bottom chords of the access bridge to prevent damages to the bottom of the structure.
- 3- Avoid storing the access bridge in a location with direct exposure to aggressive or corrosive materials in the surroundings.

Storage of the motorized unit

- 1- Follow all steps of the preparation procedure on p. 108.
- 2- Inspect the structure of the motorized unit for any sign of damage or distortion. Clean the motorized unit thoroughly to limit the effects of any corrosive agent.
- 3- Before storing the motorized unit, make sure to place sufficient cribbing under the base to prevent damages to the bottom of the structure.
- 4- Choose an appropriate storage location. Avoid storing the motorized unit in a location with direct exposure to aggressive or corrosive materials in the surroundings.



NOTICE

Before transporting or storing a motorized unit, make sure that the gasoline valve lever has been moved to the OFF position. Disconnect the battery if the motorized unit is to be stored for any significant length of time.

Lifting and moving a motorized unit or setup

The lift and relocation of a P Series motorized unit or setup must be carried out with extreme care, using appropriate, certified lifting equipment.

Safety guidelines

- 1- The **maximum length** of a P Series motorized unit setup that can be lifted and transported by a **rough terrain forklift** (by the base, using the forklift tubes) or a **crane** (using slings) is 27' 5" (8,4 m), weighing approximately 5400 lb (2449 kg).
- 2- It is **mandatory** to refer to and comply with the capacities and limitations of the lifting device as specified by the manufacturer.
- 3- It is **mandatory** to remove any installed access bridge, access stairs or additional equipment or accessory such as a front/rear extension bridge, or a hoist and hoist support structure, or a swivel bridge **before** lifting and transporting a motorized unit setup.
- 4- It is also **mandatory** to make sure that the weight of the setup is **equally balanced** on each side of the mast before lifting and transporting a P Series motorized unit setup.
- 5- A setup equipped with an **adapter base for freestanding installation** must be **lifted by the mast using a sling**.

Preparation

- 1- Before lifting and moving the motorized unit or setup, make sure that all workers have stepped down and that all tools, equipment and loads have been removed from the platform.
- 2- Make sure any installed access stair, access bridge or additional equipment or accessory has been removed.



CAUTION

It is **mandatory** to remove any installed access bridge, access stairs or additional equipment or accessory **before** lifting and transporting a P Series motorized unit setup.

Transport and Storage

Lifting and moving a motorized unit setup

Preparation (cont'd)

- 3- Remove all the planking, mast ties and mast sections, **leaving only one mast section** in place. Make sure that all the guardrails and other components are secure.
- 4- In reference to the plan/layout drawing, establish the position where the motorized unit setup must be moved to and make sure that there are no obstacles.
- 5- Make sure that the lifting, transport and destination areas are clear of workers and equipment or any obstacle liable to interfere with the operation.

Lifting a motorized unit or setup by the forklift tubes

- 1- Prepare the motorized unit or setup as described in the preparation instructions starting on p. 110 of this section.
- 2- Insert the forks in the forklift tubes located on the base of the motorized unit.
- 3- Lift and transport the motorized unit or setup over to its destination area.



Lifting and moving a motorized unit or setup by the mast – using a sling

- 1- Prepare the motorized unit or setup as described in the preparation instructions starting on p. 110 of this section.
- 2- Make sure that there is no other mast sections installed on top of the mast section welded on the base. When lifting a P Series motorized unit, the sling must be attached to the mast section welded on the base.
- 3- Make sure the sling is appropriate for the weight to be lifted.
- 4- Secure the sling to the **top first lifting rung on the back** of the mast section. If using a forklift, make sure to use an appropriate forklift attachment to secure the sling (shown in red, in fig. 8.19 and fig. 8.20).
- 5- Make sure that two workers, wearing proper personal protection (PPE), are standing on the ground using tag lines to help stabilize the structure during the lift, transport and landing of the motorized unit setup.
- 6- Lift and transport the motorized unit or setup to its destination area.

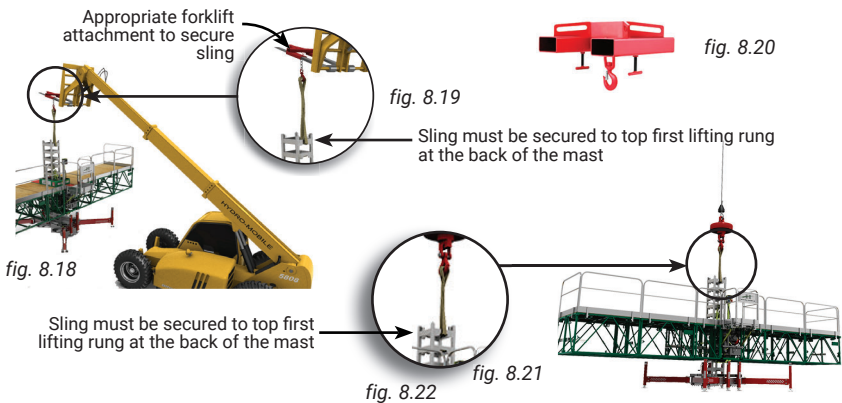

Inspections and Maintenance

Proper maintenance and service will warrant safe, economical, and dependable operation of a P Series motorized unit and its accessories. In order to ensure operational safety and avoid failures, the owner must make sure that all the scheduled inspection and maintenance operations have been effectively and timely carried out according to the inspection and maintenance schedules recommended for P Series motorized units and their accessories.

Blank copies of the daily inspection checklist must be available on job sites at all times to be filled out when daily and weekly inspection operations are carried out. Maintenance and inspection logs must be kept on record for warranty and safety purposes.

Copies of all maintenance and inspection checklists can be obtained by contacting the distributor/ service center or the Hydro Mobile technical support team or downloaded directly from the Hydro Mobile website at www.hydro-mobile.com.

Daily and Weekly Inspections and Maintenance

Daily and weekly inspections must be performed by a qualified operator. For more information about qualified operator, refer to p. 7 of the Performance and Safety Rules section.

Each Hydro Mobile motorized unit and its accessories must be submitted to daily (or before every working shift) and weekly inspections and maintenance operations performed by the qualified user/operator. For more information about qualified operators, refer to p. 7 of the *Performance and Safety Rules* section.

Daily and weekly inspection operations are only necessary when the motorized unit and its accessories are in use. The owner and/or user is responsible for all inspection and maintenance operations. Before being first used on a job site, a P Series motorized unit and its accessories must be inspected effectively and timely, according to the schedules recommended for P Series motorized units and their accessories.

Maintenance and inspection logs must be kept on record for warranty and safety purposes. Blank copies of the daily inspection checklist must be available on job sites at all times to be filled out when daily and weekly inspection operations are carried out. The notes and comments form must be used to indicate any discrepancy or any item found to be not acceptable. Any discrepancy must be reported to the owner/user and appropriate corrective action must be taken immediately. Appropriate corrective action must be taken immediately before the motorized unit can be used again. Corrective actions must be performed by qualified personnel.

Inspection and maintenance of the cylinder hook

To ensure safe and dependable operation of the cylinder hook, it is **mandatory** to inspect it **as per the maintenance schedule**. A worn rubber must be replaced immediately, before operating the motorized unit. A worn and defective rubber will prevent the cylinder hook from working correctly and engage properly on mast rungs.

- 1- Hold the cylinder firmly (fig. 8.23) and pull the hook all the way back.
- 2- Let go of the hook and verify its position.
- 3- The hook **must not lean** towards or away from the mast, but **stand up straight** as in "B" in fig. 8.24. If the position of the hook is as in "A" or "C" in fig. 8.24, the rubber must be replaced immediately.

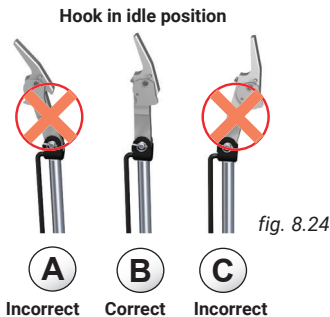
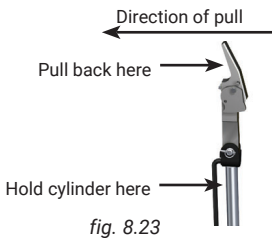

Inspections and Maintenance

Replacement of the rubber of the cylinder hook

- 1- Remove the linch pin and slide out the clevis pin (GR8) (fig. 8.25). Lift the hook from the cylinder.
- 2- Remove the defective rubber.
- 3- Cut **slight** beveled edges lengthwise on the replacement rubber (see fig. 8.26) so that it fits snugly against the welding tracks at the bottom of the pocket.
- 4- Insert the replacement rubber in the top part of the cylinder. Slide in the hook and verify that the holes in the hook and the holes in the top part of the cylinder align properly, with no more than 1/16" to 1/8" (1,6 mm to 3,2 mm) of play. **The rubber must be lightly compressed.** Trim the bottom part of the rubber until the holes align correctly.
- 5- Once the rubber fits correctly, replace the hook and secure it in place with the clevis and linch pins.
- 6- Test the operation of the cylinder hook as described in steps 1 through 3 of the inspection instructions on p. 112 of this section.

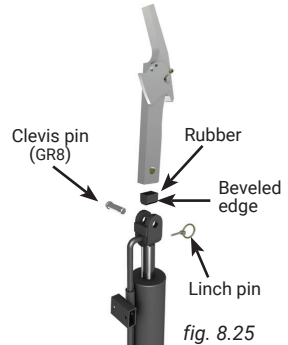

fig. 8.25

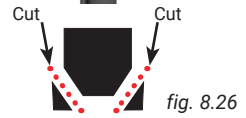

fig. 8.26

Cut beveled edges on the replacement rubber only deep enough for fitting

Greasing the mast carriage guide rollers

To ensure safe and dependable operation, it is **mandatory** to grease each mast carriage roller (16) as part of the **weekly** inspection and maintenance operations.

A proper greasing will extend the life expectancy of the rollers. Rollers (shown in red in fig. 8.28) must be greased using only Prolab GS1000 grease.

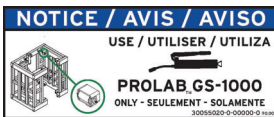

fig. 8.27

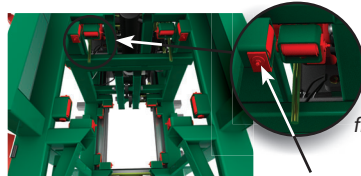

fig. 8.28 Rollers are shown in red for illustration purposes only

Grease must be applied here on each roller (16)

Greasing the base outriggers

To ensure safe and dependable operation, it is **mandatory** to grease each base outrigger as part of the **weekly** inspection and maintenance operations. Base outriggers must be greased using only Prolab GS1000 grease.

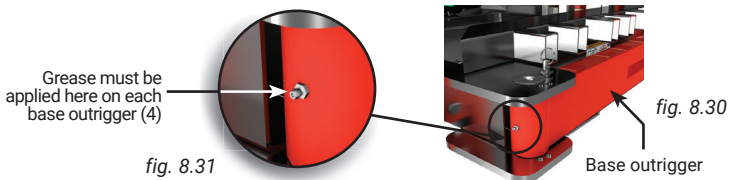

fig. 8.31

fig. 8.30

Base outrigger

Inspections and Maintenance

Inspecting and greasing the safety hooks

The safety hooks are an important part of the safety mechanism of the P Series mast climber and must be able to move freely at all times and be in appropriate working condition. To ensure the proper operation of safety hooks, they must be inspected daily and greased as part of the **frequent** and **annual** inspection and maintenance operations.

- 1- Inspect each safety hook (2) to make sure that there is no indication of a drop of the unit. If there are signs of a drop, each safety hook must be thoroughly inspected by a **qualified technician**. It is mandatory to replace any triggered safety hook and its pivot bolt immediately before resuming operation of the unit. **The replacement of a safety hook must be performed by the qualified technician.**
- 2- Inspect each safety hook to make sure that there is no indication of excessive grease. If there are signs of excessive grease, a **qualified technician** must take the safety hook apart and clean it properly.
- 3- Apply grease to each safety hook (2) as part of the **weekly** inspection and maintenance operation. Safety hooks must be greased using only Prolab GS1000 grease.



fig. 8.33

Grease must be applied here on each safety hook (2)

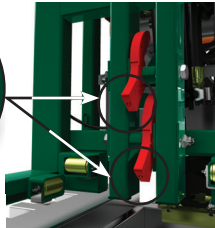

Safety hooks are shown in red for illustration purposes only

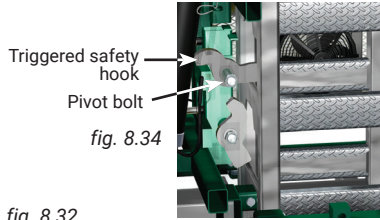

fig. 8.32

Any triggered safety hook and its pivot bolt must be replaced immediately before resuming operation of the unit

Frequent Inspections and Maintenance

Frequent inspections must be performed by a qualified technician. For more information about qualified technicians, refer to p. 7 of the Performance and Safety Rules section.

Each Hydro Mobile motorized unit must be submitted to a frequent inspection performed every three months by a qualified technician (see box above).

Maintenance and inspection logs must be kept on record for warranty and safety purposes. Blank copies of the frequent inspection checklist must be filled out when frequent inspection operations are carried out. The notes and comments form must be used to indicate any discrepancy or any item found to be not acceptable. Any discrepancy must be reported to the owner/user and appropriate corrective action must be taken immediately. Corrective actions must be performed by a qualified technician. For more information about qualified technicians, refer to p. 7 of the *Performance and Safety Rules* section.

All inspection and maintenance steps included in the daily inspection checklist must be performed before the frequent inspection and maintenance steps.

It is recommended to use replacement parts manufactured by or recommended by Hydro Mobile. The use of substitute parts could not only void the warranty covering this motorized unit and its components but cause serious damages that could lead to injury or death. It is recommended to replenish and grease components only with fluids and lubricants recommended by Hydro Mobile.

Inspections and Maintenance

Annual Inspections and Maintenance

Annual inspections must be performed by a qualified technician. For more information about qualified technicians, refer to p. 7 of the *Performance and Safety Rules* section.

Each Hydro Mobile motorized unit must be submitted to an annual inspection performed by a qualified technician. This annual inspection must be carried out **no later than 13 months after the previous annual inspection**.

Maintenance and inspection logs must be kept on record for warranty and safety purposes. Blank copies of the annual inspection checklist must be filled out when annual inspection operations are carried out. The notes and comments form must be used to indicate any discrepancy or any item found to be not acceptable. Any discrepancy must be reported to the competent person and appropriate corrective action must be taken immediately. Corrective actions must be performed by a qualified technician. For more information about qualified technicians, refer to p. 7 of the *Performance and Safety Rules* section.

It is recommended to use replacement parts manufactured by or recommended by Hydro Mobile. The use of substitute parts could not only void the warranty covering this motorized unit and its components but cause serious damages that could lead to injury or death. It is recommended to replenish and grease components only with fluids and lubricants recommended by Hydro Mobile.

Copies of inspection and maintenance checklists shown below can be obtained by contacting the distributor/service center or the Hydro Mobile technical support team or downloaded directly from the Hydro Mobile website at www.hydro-mobile.com.

Daily inspection checklist

The Daily Inspection Checklist form includes a header with a warning triangle icon and a title bar. It contains several sections for recording inspection data, including a large table with multiple columns and rows for detailed notes and observations.

fig. 8.35

Frequent inspection checklist

The Frequent Inspection Checklist form features a header with a warning triangle icon and a title bar. It includes a table for recording inspection results and a section for additional notes and comments.

fig. 8.36

Annual inspection checklist

The Annual Inspection Checklist form has a header with a warning triangle icon and a title bar. It contains a table for recording inspection data and a section for detailed notes and comments.

fig. 8.37

Copies of the job survey checklist and the handover checklist shown below can be obtained by contacting the distributor/service center or the Hydro Mobile technical support team or downloaded directly from the Hydro Mobile website at www.hydro-mobile.com.

The Job Survey - Job Hazard Analysis form includes a header with a title bar and a section for recording job details. It features a large table for hazard analysis and a section for additional notes and comments.

fig. 8.38

The Installation Handover Sheet form has a header with a title bar and a section for recording installation details. It includes a table for recording handover information and a section for additional notes and comments.

fig. 8.39

Inspections and Maintenance

Stickers

General information stickers



ORDER CODE: A0800600-0001



ORDER CODE: A0800300-0011 ("B")

ORDER CODE: A0800300-0015 ("C")

Hazards warning stickers



ORDER CODE: 30055000-0-00000-0



ORDER CODE: 30055010-0-00000-0

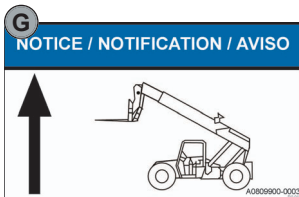

ORDER CODE: A0800900-0003



ORDER CODE: A0800400-0002



ORDER CODE: 30055080-0-00000-0



ORDER CODE: 30055070-0-00000-0

Operation instructions stickers



ORDER CODE: A0800900-0006



ORDER CODE: 30055030-0-00000-0

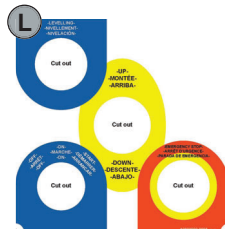

ORDER CODE: A0800900-0008

Inspections and Maintenance

Stickers

Inspection validation and maintenance stickers

T **NOTICE / AVIS / AVISO**

USE / UTILISER / UTILIZA

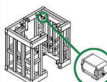

PROLAB_GS-1000
ONLY - SEULEMENT - SOLAMENTE

30055020-0-00000-0 R.020

U **NOTICE - AVIS - AVISO**

USE DEXRON® III ONLY

UTILISER SEULEMENT DU DEXRON® III

UTILIZA SOLO DEXRON® III

100000-0-00000-0 R.020

ORDER CODE: 11055060-0-00000-0

V **WARNING • AVERTISSEMENT • ADVERTENCIA**

Inspections and non destructive testing must be performed by a qualified person.
Failure to complete the required inspections and tests could result in serious injury or death.
Validation stickers must be updated further to each test and inspection. Refer to Hydro Mobile owner's manuals for complete instructions.

Les inspections et les essais non destructifs doivent être effectués par une personne qualifiée.
Le défaut d'effectuer les inspections et les essais peut entraîner des blessures sérieuses ou la mort.
Les autocollants de validation doivent être mis à jour après chaque essai et chaque inspection. Consultez le Guide de l'utilisateur de Hydro Mobile pour obtenir toutes les instructions complètes.

Una persona calificada debe llevar a cabo las inspecciones y las pruebas no destructivas.
Elle como resultado de las inspecciones y las pruebas incorrectas pueden ocasionar graves lesiones o incluso la muerte.
Las etiquetas adhesivas de validación deben actualizarse después de cada prueba e inspección. Consulte la Guía del usuario de Hydro Mobile para obtener todas las instrucciones.

HYDRO MOBILE

ORDER CODE: 99055000-0-00000-0

W **FREQUENT INSPECTION**
INSPECTION FREQUENTE • INSPECCION FRECUENTE

HYDRO MOBILE

valid until • valide jusqu'à • válido hasta

DAY - JOUR - DIA MONTH - MOIS - MES

0	1	2	01	02	03	04	05	06	
1	3	4	5	07	08	09	10	11	12
2	6	7	8	YEAR - ANNÉE - AÑO					
3	9		21	22	23	24	25	26	

99055010-0-00000-0 R.021

ORDER CODE: 99055010-0-00000-0

X **ANNUAL INSPECTION**
INSPECTION ANNUELLE • INSPECCION ANUAL

HYDRO MOBILE

valid until • valide jusqu'à • válido hasta

MONTH - MOIS - MES

01	02	03	04	05	06
07	08	09	10	11	12
YEAR - ANNÉE - AÑO					
22	23	24	25	26	27

99055020-0-00000-0 R.023

ORDER CODE: 99055020-0-00000-0

Y **NON DESTRUCTIVE STRUCTURAL TESTING**
ESSAI NON DESTRUCTIF DE STRUCTURE • PRUEBAS ESTRUCTURALES NO DESTRUCTIVAS

HYDRO MOBILE

valid until • valide jusqu'à • válido hasta

MONTH - MOIS - MES YEAR - ANNÉE - AÑO

01	02	03	04	05	06	24	25	26	27	28	29
07	08	09	10	11	12	30	31	32	33	34	35

99055030-0-00000-0

ORDER CODE: 99055030-0-00000-0

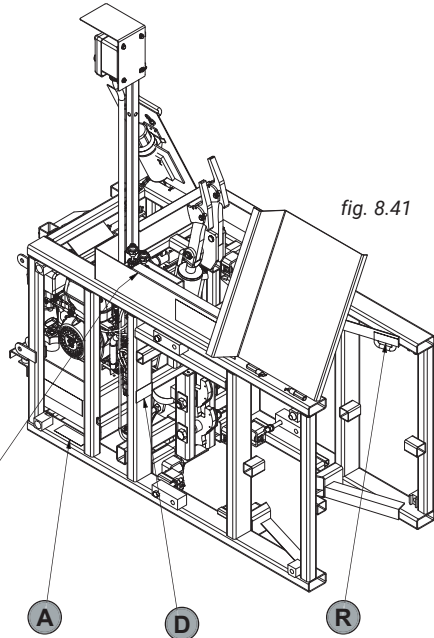

fig. 8.41

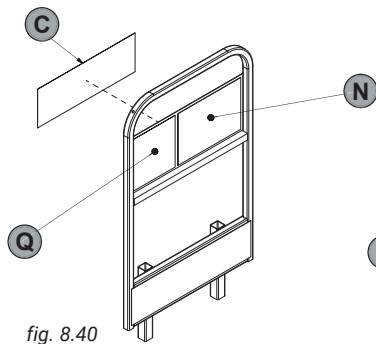
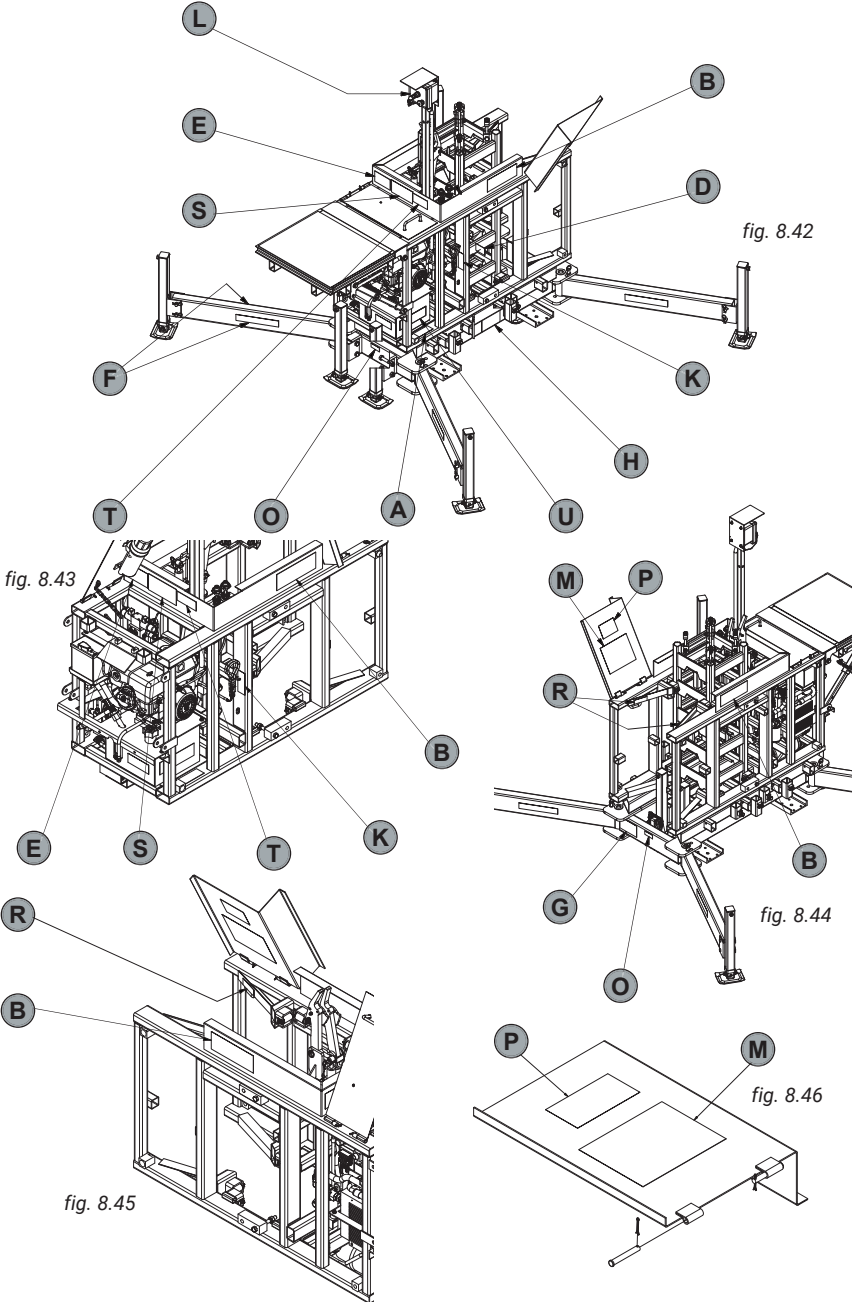

fig. 8.40

Inspections and Maintenance

Stickers



Inspections and Maintenance

Hydraulic Diagram V6

# ITEM	CODE	DESCRIPTION
1	11031400-K-02000-0	ENGINE HONDA 9 HP KIT - M2
2	A0411500-0009	ENGINE HYDRAULIC GEAR PUMP PLP 10-8 (P)
3	A0470203-0009	VALVE CHECK CVT-04-SAE
4	A0470204-0001	VALVE RELIEF CARTRIDGE TYPE (RV5-10)
5	A0470210-0006	VALVE DIRECTIONAL ELECTRIC 12VDC - P
6	A0580000-0001	CYLINDER 3 1/2x23 1/2x1 1/2
7	A0470200-0000	VALVE COUNTERBALANCE SUN 3000 PSI(W/CAP)
8	11018102-0-00000-0	CYLINDER ASS'Y - M2
9	30031202-0-00000-0	HYDRAULIC OIL COOLER ASS'Y 2015 KBV
10	30031600-0-01000-0	EMERGENCY ELEC. MOTOR 110V SUB ASS'Y - P
11	A0471704-0003	12 SAE PORT FILTER HOUSING
12	A0410000-0004	ENGINE FILTER ELEMENT (MP FILTRI)

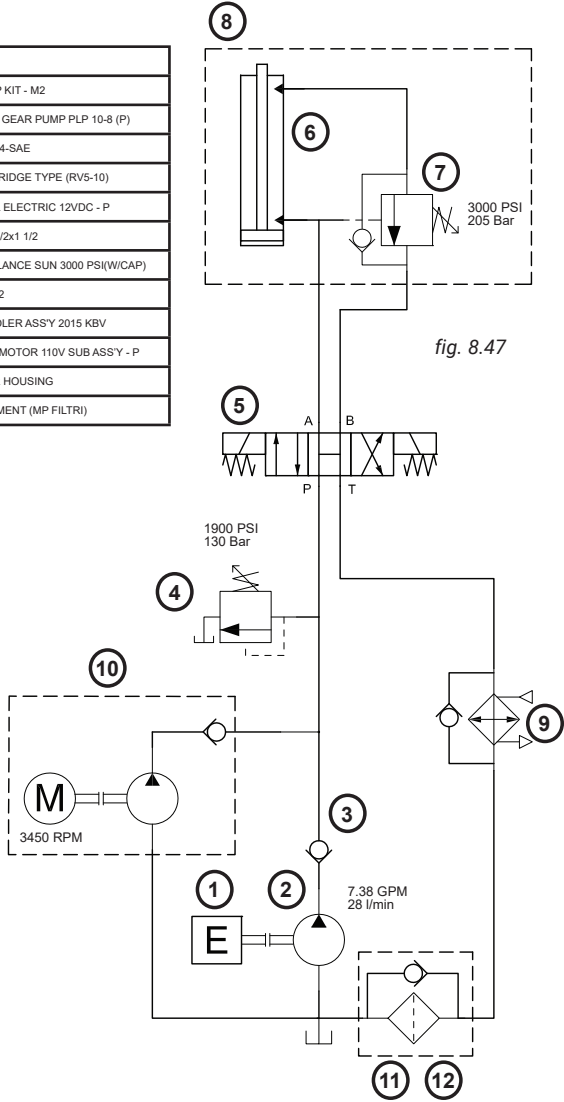

THIS HYDRAULIC DIAGRAM APPLIES TO UNITS EQUIPPED WITH A HONDA GX270 ENGINE BEARING SERIAL NUMBER PU-0832 and up

Inspections and Maintenance
Circuit Diagram for V6 units

THIS CIRCUIT DIAGRAM APPLIES TO UNITS EQUIPPED WITH A HONDA GX270 ENGINE BEARING SERIAL NUMBER PU-0832 and up

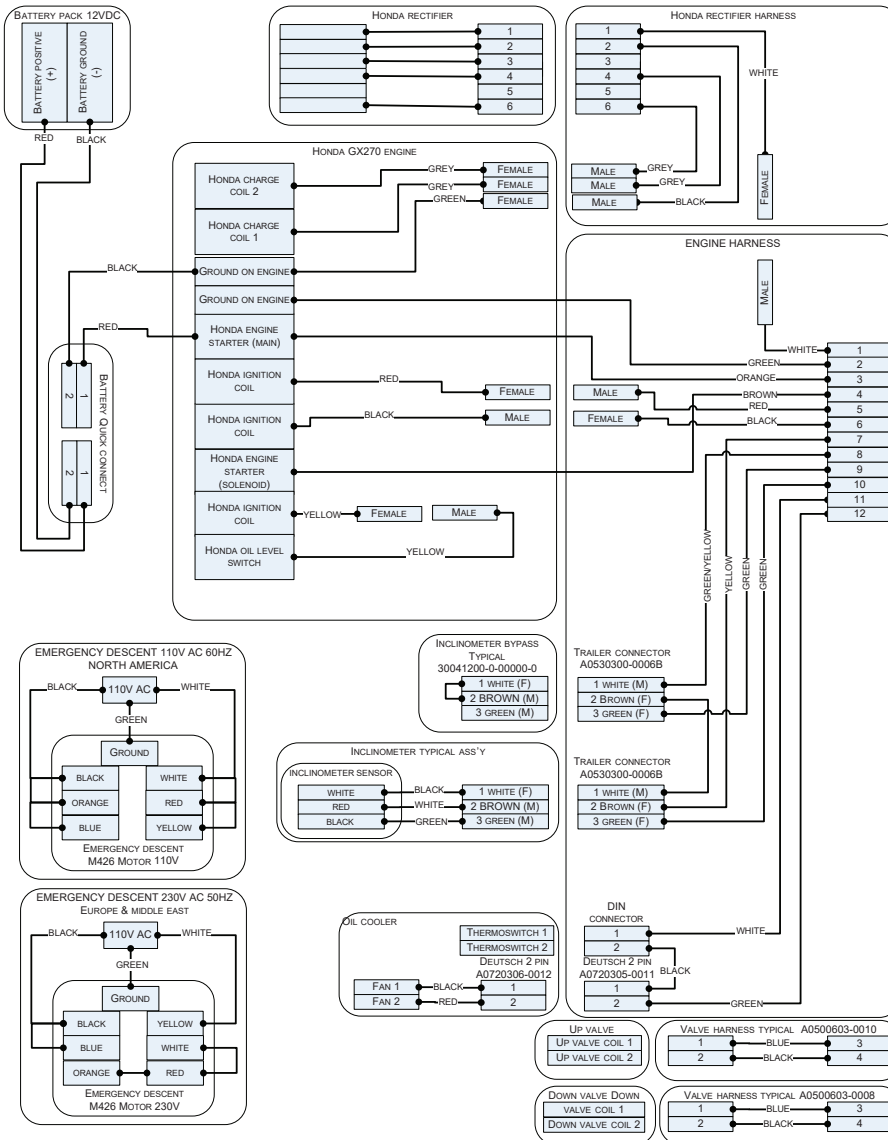

fig. 8.48

Inspections and Maintenance
Circuit Diagram for V6 units

