

Owner's Manual

for the
Transport Platform with Car system



ELEVATING
EFFICIENCY

Call us for information:
1-888-484-9376 (US)
(toll free in the United States)
(450) 589-8100 (Canada)



50053011-0-00000-0
S-TPC_OpMan_v1.04_EN

NOTE

All assembly and operation instructions located on the motorized unit and the transport platform car take precedence over information contained in this manual. Should there be any discrepancies discovered throughout any published documentation issued by Hydro Mobile or its authorized affiliates, the following order of precedence shall prevail:

1. Written documents issued by the Hydro Mobile Engineering department
2. Recall instructions
3. Assembly or operation instructions displayed on the motorized unit and on the transport platform car
4. Owner's manual

Any use of a Hydro Mobile motorized unit or transport platform car, with or without accessories, in such a configuration or manner as not explicitly described in this manual is prohibited without the prior written permission of Hydro Mobile.

Revision List

Code / Version	Date	Description
A0680007-0001 v1.0	Dec 2015	First edition of Owner's manual
A0680007-0001 v1.01	Feb 2016	Modifications to the mast tie installation schedule, mast tie installation instructions and load capacity chart
50053011-0-00000-0 v1.02	December 2018	Modifications to installation procedure; addition of dismantling procedure; modifications to control panel section
50053011-0-00000-0 v1.03	July 2020	Additions to the instructions for the adjustment, resetting and testing of switches and sensors; inclusion of illustrated instructions for installation of mast sections and tie levels; inclusion of temperature of operation; additions to emergency descent procedure; additions to mast section installation instructions; changes to mast tie schedule; inclusion of wall tie types and additional wall tie instructions; additions to jib arm installation instructions and inclusion of mouting bracket for electric chain hoist; additions to instructions for the preparation of motorized unit for transport, lifting and moving the motorized unit and lifting and moving the transport platform car; update of safety icons; inclusion of movable mast buffer assembly; introduction of tie spacing distribution; introduction of E&D load capacity and methods to install and remove mast sections and tie levels (using car or assembled lengths of mast)
50053011-0-00000-0 v1.04	Aug 2024	Changes to credits and introduction pages

LEGEND OF ICONS

These icons are used to highlight important information throughout this manual



Danger
Immediate hazard: if not avoided, will result in serious injury, even death



Notice
Useful information to avoid equipment damage



Warning
Hazardous situation: if not avoided, could result in serious injury, even death and equipment damage



Information
Useful information for safe and easy operation



Caution
Potentially hazardous situation: if not avoided, may result in minor or moderate injury and equipment damage



Useful tip
A useful tip to facilitate installation or operation

The information and instructions contained in this manual applies to S Series units for transport platform with car application bearing the following serial numbers

STP-0001 and up



HYDRO MOBILE

www.hydro-mobile.com

125 de l'Industrie

L'Assomption, Quebec,
Canada J5W 2T9

For orders or information:
1-888-484-9376 (US)
(toll free in the United States)
(450) 589-8100 (Canada)

50053011-0-00000-0

General Information

Motorized unit serial number _____

Manufacturing date _____

TABLE OF CONTENTS

General Information	
Introduction.....	5
Warranty.....	6
Performance and Safety	
Performance and safety rules.....	7
1 - Transport Platform System	
Overview.....	10
List of components included.....	10
Motorized unit specifications.....	11
Weight of components.....	12
Dimensions of unit and transport platform car.....	13
Minimum bearing surface capacities table.....	14
General guidelines.....	15
Installation procedure for right side of unit.....	16
Positioning the motorized unit.....	17
Installation of the first two tie levels.....	19
Installation of the extensions and the transport platform car and guardrails.....	20
Installation of the safety stop.....	21
Completing the installation of mast sections and tie levels.....	21
Installation of mast sections using the transport platform car.....	23
Installation of pre-assembled lengths of mast sections and tie levels.....	25
Dismantling procedure for right side of unit.....	27
Preparing the installation for dismantling.....	27
Removal of mast sections and tie levels.....	29
Removal of last two tie levels.....	30
Removal of tie levels using the transport platform car.....	32
Removal of tie levels and assembled lengths of mast sections.....	32
Standard motorized unit.....	32
Removing the main frame.....	33
Reinstalling the main frame.....	33
2 - Safety Devices	
Emergency descent control system.....	35
Centrifugal brakes.....	35
Fall protection.....	36
Safety stop.....	36
Gate detection switches.....	38
Verification of sensors, switches and screen alerts.....	41
Qualified technician or qualified erector/dismantler only.....	41
Qualified operator.....	42
3 - Transport Platform Car and Extensions	
Installation of the rear extension.....	45
Installation of the lateral extension.....	46
Installation of the transport platform car.....	46
Adjusting the spacing of the main trolley structure.....	47
Installation of the sliding gate.....	47
Installation of the extension guardrails.....	48
Mast tie installation deck.....	48
Installation.....	49
Removal.....	49
Loading the transport platform car.....	49
Unloading the transport platform car.....	49
Proper seating of landing ramp.....	50
4 - Power Pack and Operating Components	
General guidelines.....	51
Power cable selection chart.....	51
Installation without an optional cable trolley.....	51
Installation with an optional cable trolley.....	52
Motorized unit startup procedure.....	52
Motorized unit shutdown procedure.....	52
5 - Control Panel	
Description.....	53
Controls.....	54
Screen alerts and instructions.....	55
Unlocking the display screen.....	55
Main menu screen.....	55
F1 – Status info.....	55
F2 – Alerts.....	56
F3 – Inputs and outputs.....	62
F4 – Configuration.....	62
Performing a position reset.....	63
Preventing unauthorized operation of the motorized unit.....	63
Connection of the remote control pendant.....	64

6 - Mast and Mast Ties	
Mast sections	
Installation of a single mast section.....	65
Removal of a single mast section.....	66
Transport and storage of mast sections.....	66
Mast ties	
Pre-installation of tie levels	
General guidelines.....	66
Calculating the proper sequence for tie level distribution.....	67
Mast tie installation schedule.....	70
Recommended order of installation.....	70
Angle of installation of mast ties.....	70
Wind speeds warning.....	70
Mast tie requirements.....	71
Installation of mast ties with extensions.....	71
Removal of mast ties.....	73
Anchoring system	
Wall tie reactions.....	73
Installation guidelines for horizontal anchoring.....	74
Installation of wall ties.....	74
Wall tie types.....	74
Re-usable wall tie.....	75
Welded wall tie on a beam.....	70
7 - Load Capacities	
General guidelines.....	76
Load capacity chart.....	76
8 - Accessories	
Jib arm	
Installation on the motorized unit.....	77
Using the jib arm to lift a mast section.....	78
Mounting bracket for electric chain hoist.....	78
Cable trolley.....	81
Movable buffer assembly.....	84
Multiple mast handler.....	86
9 - Transport, Storage and Maintenance	
Transport	
Preparation of the motorized unit and the transport platform car for transport.....	88
Lifting and moving the motorized unit.....	88
Using the forklift tubes.....	88
Using the D-rings.....	88
Using the rear mast head.....	89
Lifting and moving the transport platform car.....	89
Storage	
Preparation of the motorized unit for storage.....	90
Storage of the transport platform car.....	90
Storage of the platform extensions.....	90
Storage of the sliding gate and the guardrails.....	90
Storage of the outrigger support.....	90
Storage of mast sections.....	90
Storage of the motorized unit.....	90
Inspections and maintenance	
Daily and week inspections.....	91
Greasing of gears and racks.....	91
Frequent inspections and maintenance.....	93
Annual inspections and maintenance.....	93
Samples of checklists.....	94

Introduction

Dear owner or user:

Thank you for investing in a Hydro Mobile S Series transport platform with car system. The design of this transport platform system reflects over a decade of continued field operation, testing and research work and comes as a solution to our company's deepest concern, your safety and well being on the job.

To ensure that the workplace becomes safer and more efficient using a Hydro Mobile system, always have appropriately trained personnel assemble, operate, dismantle and move your transport platform system. These qualified persons will be required to read this owner's manual and assimilate the information contained herein. Failure to do so could lead to serious injury and/or equipment damage.

The transport platform was designed in accordance with the standard US ANSI A92.10-2009. Furthermore, the transport platform system and its owner's manual comply with US Federal Occupational Safety and Health Administration Standards (OSHA), as well as with CSA B354.12-2017, B354.13-2017 and B354.14-2017.

To ensure safety, maximize the life expectancy of your equipment, and enjoy years of dependable and secure operation, this Hydro Mobile system must be inspected and serviced according to maintenance schedules and recommendations provided in this manual. It is also advised to refer to the motor user's manual included with the motorized unit.

Should you have any questions or concerns, please contact the nearest authorized service center or Hydro Mobile directly at 888-484-9376 (in the United States) or at 450 589-8100 (in Canada). You can also visit our website at www.hydro-mobile.com for additional support and information on our factory safety and performance training seminars.

We wish you years and years of safe, productive construction and renovation work.



WARNING

To ensure that the workplace becomes safer and more efficient using a Hydro Mobile system, always have appropriately trained personnel assemble, operate, dismantle and move your transport platform system. These qualified persons will be required to read this owner's manual and assimilate the information contained herein. Failure to do so could lead to serious injury and/or equipment damage.

Warranty

Hydro Mobile Warranty Policy

Warranty period

Hydro Mobile, a division of AGF Access Group, Inc., herein referred to as Hydro Mobile, warrants its new S Series motorized units to be free from defect of materials and workmanship for a period of 15 months or a maximum of 650 operating hours whichever occurs first from the date of delivery to the authorized distributor/service center.

Hydro Mobile also warrants its new S Series parts and accessories to be free from defect of materials and workmanship for a period of 15 months from the date of delivery to the authorized distributor/service center.

Product registration

In accordance with standards governing mast climbing work platform and transport platform systems, the owner of a Hydro Mobile S Series unit **must register the product with Hydro Mobile within sixty (60) days**. The initial buyer of a Hydro Mobile S Series unit is automatically registered by Hydro Mobile.

Hydro Mobile must be kept informed of any change of ownership. The new owner must provide Hydro Mobile with a full name and address, along with the model and serial number of the unit acquired.

Description of warranty

Parts and accessories manufactured by Hydro Mobile

Hydro Mobile's obligation and liability under this warranty are expressly limited to repairing or replacing with re-manufactured or new parts, at Hydro Mobile's option, any part and accessory manufactured by Hydro Mobile proven defective after inspection by Hydro Mobile which appear to have been defective in material or workmanship. Only permanent repairs will be covered under this warranty. Hydro Mobile reserves the right to ask for maintenance records of the defective part before settling a claim and to deny such claim if maintenance records are not available or not compliant with maintenance schedules.

This warranty shall not apply to component parts or accessories of products not manufactured by Hydro Mobile and which carry the warranty of the manufacturer thereof or to normal maintenance (such as engine tune-up) or any part necessary to perform such maintenance. Hydro Mobile offers no other warranty, expressed or implied, and offers no warranty of merchantability or fitness for any particular purpose.

Motor

All motors and gear boxes manufactured by Nord Gear Limited are covered by an international warranty of 15 months. To have a motor or a gear box repaired under this warranty, the motor or gear box must be brought to an authorized Hydro Mobile distributor/service center.

Costs and liability associated with warranty

Hydro Mobile's obligation under such warranty shall not include duty, taxes or any other charge whatsoever, or any liability for direct, indirect, incidental or consequential damage or delay.

Exclusion

Any use of one or several Hydro Mobile motorized units, with or without accessories, in such a configuration or manner as not explicitly described in the owner's manual is prohibited without the prior written permission of Hydro Mobile.

Any improper use, including operation after discovery of defective or worn parts, shall void this warranty. Improper use also includes operation beyond rated capacity, substitution of parts other than those approved by Hydro Mobile, including anchor systems, or any alteration, modification or repair by others in such manner as in Hydro Mobile's judgment affects the product materially and adversely.

Labor

All warranty work must be performed by a certified Hydro Mobile technician to be eligible for reimbursement under the warranty.

Performance and Safety Rules



SAFETY comes first. The installation and operation of a transport platform with car system is subject to hazards that can be avoided only by using extreme care and common sense, and by providing the **appropriate training and supervision** to all its users.

It is essential that the **installation** and **dismantling** of an S Series transport platform with car system be carried out according to the guidelines, instructions and warnings included in the owner's manual and performed by **qualified erectors/dismantlers** under the supervision of a **competent person** (see boxes below).

It is also imperative that the **operation** of an S Series transport platform with car system setup be carried out according to the guidelines, instructions and warnings included in the owner's manual. To ensure safe and proper operation, it is **mandatory** that the operation of a transport platform system be handled by a **qualified operator** (see box below).

N	NOTICE
<p>This owner's manual for the S Series transport platform car provides the method to achieve a right-hand side configuration (right side of the unit). For instructions on how to achieve a left-hand side configuration, contact the Hydro Mobile technical team.</p>	

Definition of the competent person
<p>Competent person means a person who is capable of identifying existing and predictable hazards in the surroundings or working conditions which are unsanitary, hazardous or dangerous to employees, and who has authorization to take prompt corrective measures to eliminate them.</p>

Definition of the qualified person
<p>"Qualified" means a person who, by possession of a recognized degree, certificate or professional standing, or who by extensive knowledge, training and experience, has successfully demonstrated the ability to solve or resolve problems relating to the subject matter, the work or the project.</p> <p>Only a qualified person on the specific make and model of the Hydro Mobile equipment can carry out the following tasks:</p> <p>User/operator A qualified user/operator is allowed to operate Hydro Mobile units according to the guidelines, instructions, warnings and methods set out in the owner's manuals and Hydro Mobile training courses and after they have been erected, tested and passed for use by a qualified person.</p> <p>Erector/dismantler A qualified erector/dismantler is allowed to erect, dismantle, test, pass for use and modify the configuration of Hydro Mobile units according to the guidelines, instructions, warnings and methods set out in the owner's manuals and Hydro Mobile training courses.</p> <p>Technician A qualified technician is allowed to perform maintenance inspections and repairs on Hydro Mobile units according to the guidelines, instructions, warnings and methods set out in the owner's manuals and Hydro Mobile training courses.</p>

<p>Hydro Mobile recommends that Qualified Persons follow the Hydro Mobile University Training Program on the specific task and specific make and model to get proper qualifications. For more information on the Hydro Mobile University Training Program, visit www.hydro-mobile.com/training</p>
--

General guidelines

- 1- Prepare a layout plan showing how the transport platform with car system will be positioned near structures or walls to be erected. Make sure to position the motorized unit so as to provide proper anchoring points for the mast.
- 2- It is recommended to use the job survey form as a guide for the proper installation of the configuration. Refer to p. 94 of the *Transport, Storage and Maintenance* section for more information about the job survey form.
- 3- It is **mandatory** to refer to the *Mast Tie Schedule* table on p. 70 of the *Mast and Mast Ties* section and to the *Load Capacities* section on p. 76 **before the installation of any** S Series transport platform car setup.
- 4- Establish the distance between the mast climbing transport platform system and the structure or wall, taking into account curvatures, balconies, columns, trees, telephone wires, electrical lines, etc.

Performance and Safety Rules

- 5- Refer to and follow local regulations governing distances between the transport platform system and electrical lines. As a reference, North American regulations generally recommend keeping a minimum safe approach distance (MSAD) of at least 10' (3 m) from overhead power lines carrying 50 000 volts or less.
- 6- Make sure the ground or support surface capacity meets with values included in the *Minimum Bearing Surface Capacities* table herein (fig. 1.17, p. 14). Soil compacting, cribbing or shoring can increase bearing capacity. The **jacks on the base** are designed to plumb the mast and **must not be used to support the load nor the motorized unit**. Contact a licensed engineer for assistance.
- 7- Never modify the transport platform system (including the motorized unit) or use substitute parts. This could adversely affect worker safety, unit performance and void the warranty. In addition, this could lead to serious injury or death.
- 8- Each S Series transport platform with car system must be equipped with an appropriate fire extinguisher (not supplied). Use the bracket supplied with the motorized unit to hang the fire extinguisher on a guardrail on the rear or the lateral extension (fig. 1.1, p. 10).
- 9- It is recommended not to smoke on the platform.
- 10- Workers exposed to potential hazards must always wear proper personal protection equipment (PPE) such as a helmet, safety boots, a fall arrest harness, etc., as prescribed by local regulations. In all cases where workers are exposed to fall hazards, fall protection is required. Installation of all the necessary guardrails is **mandatory**. Tie points (D-rings) located on the main trolley of the motorized unit (fig. 1.4, p. 10) are designed to resist to a maximum arrest force of 5000 lb (2268 kg) and can be used by workers to tie themselves to the unit (not more than one worker per D-ring).
- 11- The S Series transport platform with car system must not be used on a mast with a height over 500' (152 m). To maximize efficiency and because of the speed of travel, it is recommended to use the S Series transport platform with car system on a mast with a height of 200' (61 m) or less. The use of the optional cable trolley kit is recommended for an installation on a mast higher than 150' (45,7 m).
- 12- The S Series transport platform with car system must not be used with any equipment or any accessories not specifically manufactured and rated by Hydro Mobile to be used in an S Series modular transport platform application.
- 13- To ensure work efficiency, maintain an adequate equipment and parts inventory on the job site. Keep equipment in good condition.
- 14- Inspection and maintenance operations must be carried out efficiently and in a timely manner. Daily inspections and their related operations must be performed by a **qualified user/operator** every day or before every working shift. Frequent and annual inspections and their related operations must be carried out by a **qualified technician**. Refer to the *Transport, Storage and Maintenance* section on p. 88 for more information on inspection and maintenance requirements for S Series motorized units and their accessories.
- 15- The **qualified erectors/dismantlers** in charge of the installation must make sure that the equipment being installed has been duly inspected and meets all applicable safety standards.
- 16- **Prior to installation, prepare an emergency evacuation plan that is specific to the job site and is in accordance with local regulations.**
- 17- After installation, mark off limit areas of the system using fencing, barriers, warning tape and note emergency phone numbers (fire and police dept.) for quick reference.
- 18- No load must be applied on a guardrail or a gate. Material must be stored away from guardrails and platform gates. It is also forbidden for anyone to lean on a guardrail or a gate.
- 19- Contact the distributor/service center or Hydro Mobile for service, repair or technical advice. Refer to equipment type and serial number when calling.
- 20- Before the installation can be passed for use, it is **mandatory** make sure that **building landing gates** are installed on each level that will be accessed by the transport platform and that they conform to local regulations.
- 21- In the event of an abnormal occurrence or operation which could compromise safety (for example, malfunction of a motorized unit component, collision with an obstacle, etc.), immobilize the unit and inform the **competent person**.

Performance and Safety Rules

- 22- Do **NOT** touch any of the moving parts on the transport platform system when it is in use.
- 23- All platform gates and access panels on the transport platform and the motorized unit must be closed when they are not in use. All platform gates and access panels must be free from any material or obstruction.
- 24- Make sure that the roof of the transport platform car is clear of any accumulation of debris, snow or ice at all times. **No load is allowed on the roof** of the transport platform car at all times.
- 25- The motorized unit must not be used or operated during an electrical thunderstorm. The motorized unit and its components must not be used as ground for electrical connections. A motorized unit that is exposed to a thunderstorm must be submitted to a daily inspection by a qualified person before operation can be resumed. For the definition of a qualified person, refer to p. 7 of this section.
- 26- When the transport platform is moving, it is **mandatory** for all workers to stand inside the enclosed area of the platform. Nothing must overhang or be protruding from the transport platform enclosure **at all times** (material, body parts, etc.).
- 27- The placing of loads in the transport platform car must be done with extreme care, under proper supervision. Never load the transport platform beyond its rated capacity. Overloading may bring damages to equipment or cause the installation to become unbalanced, leading to serious injury or death.
Refer to the *Load Capacities* section on p. 76 for more information about loads allowed inside the transport platform car. When the transport platform system is not in use, the motorized unit must be brought down to base level and all loads must be removed from the transport platform car.
- 28- In the event of a power outage, it is recommended that all workers remain inside the car as a safety precaution until the power is restored. If the power has not been restored within a reasonable time, the emergency descent system must be used to bring the workers safely back to the nearest safe evacuation point. Refer to p. 37 of the *Safety Devices* section for more information on the use of the emergency descent system.



WARNING

The **erection and dismantling** of a transport platform (including the motorized unit, the base, the car assembly, the masts, the mast ties and all the other components) must not be conducted when wind speeds exceed **28 mph (45 km/h)**. A transport platform **must not be operated** when wind speeds exceed **35 mph (56 km/h)**. It is important to inspect every component of a transport platform installation that has been exposed to winds exceeding 102 mph (164 km/h).

When the transport platform is not in use:

- The motorized unit must be brought down to base level
- All loads must be removed from the transport platform car



WARNING

It is **mandatory** to refer to the *Mast Tie Schedule* table on p. 70 of the *Mast and Mast Ties* section **before the installation** of any S Series transport platform car installation. Failure to follow the mast tie schedule for an S Series transport platform with car application could compromise the integrity of the installation, leading to serious injury or death.



WARNING

It is critical to make sure that all components installed (lateral and rear extensions, transport platform car) **remain in place at all times until the setup is dismantled**.



CAUTION

It is essential to make sure that the floor of the transport platform car has the proper bearing capacity.

Transport Platform with Car System

Overview

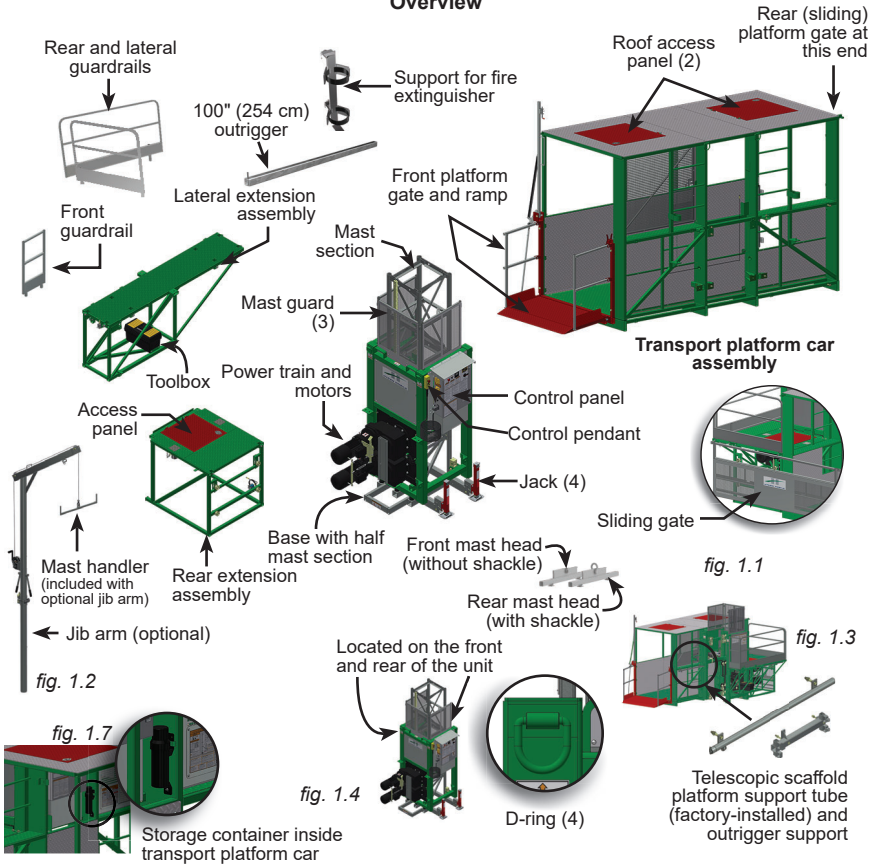

Note: Items depicted in illustrations throughout this manual may differ from actual products. Only one mast section (in addition to the half mast section welded on base) is included with the S Series motorized unit for transport platform car application.

fig. 1.5

fig. 1.6

List of components included with shipped S Series transport platform with car system (including motorized unit)			
Qty	Component	Qty	Component
1	S Series motorized unit for transport platform with car application (including remote control pendant and one full mast section)	1	Transport platform car assembly (including front platform gate and ramp)
1	Owner's manual	1	10' (3 m) rear (sliding) gate
1	Base for transport platform with car application	1	Scaffold plank support tube (bolted on car assembly)
1	Lateral extension assembly (including 100" or 254 cm outrigger)	1	Rear extension assembly
1	95" (241 cm) lateral guardrail	1	68" (173 cm) rear guardrail
1	Outrigger support assembly	1	20" (51 cm) front guardrail
2	Mast heads	1	Support for fire extinguisher

Note: When purchasing only an S Series Transport Platform Car assembly, the unit and full mast section are not included. The control pendant is only included with the S Series motorized unit for transport platform car application. Components included with shipped unit or shipped car assembly are subject to change without any further notice.

Toolbox Components	
Qty	Description
2	Limit triggers
1	Cable support kit
1	10-foot stop limit switch kit
2	12.5 oz (370 ml) aerosol can of grease for rack and pinion

fig. 1.8

Storage Container Components	
Qty	Description
1	15/16" open end wrench
1	Owner's manual

Transport Platform with Car System

Motorized Unit Specifications

fig. 1.9

General Specifications		
Motorized unit dimensions (for transport)	77 3/4" x 85" x 102" (W x L x H) (197,5 cm x 216 cm x 259 cm)	
Transport platform car dimensions (for transport)	87 1/4" x 166" x 101 3/4" (W x L x H) (222 cm x 422 cm x 258 cm)	
Weight of motorized unit for transport platform car application (as shipped)	4950 lb (2245 kg)	
Weight of transport platform car assembly (with platform extensions and guardrails, sliding gate, outrigger support stored inside the car)	4695 lb (2130 kg)	
Dimensions (inside) of transport platform car	60" x 155" x 92" (W x L x H) (152 cm x 394 cm x 234 cm)	
Maximum height of mast	Up to 500' (152 m) of mast 200' (61 m) of mast recommended to maximize efficiency and because of the speed of travel	
Freestanding	Not allowed	
Distance between tie levels	Up to a maximum of 30' (9,1 m)	
Maximum load capacity	5200 lb (2359 kg) + 1 operator	
Drive system	Rack and pinion drive	
Vertical travel speed	240 VAC, 60 Hz 30' (9,1 m) per minute	
Mast section (1-rack)	28 9/16" x 30" x 60" (71,5 cm x 76 cm x 152 cm) 330 lb (150 kg) per section	
Safety devices	Emergency descent	Gravity-activated manual descent system
	Centrifugal brake	Centrifugal brake / maximum speed of descent 34 ft/min (10,4 m/min)
	Safety stop	Safety stop switch at 10' (3 m) from base level
	Platform gates	Two gates equipped with electric interlock

fig. 1.10

Operation Specifications	
Wind exposure	
	Maximum wind speed allowed
During operation	35 mph (56 km/h)
During erecting and dismantling	28 mph (45 km/h)
When unit is out of service	Transport platform must be brought down to base level
* The transport platform must only be used on a mast whose height does not exceed 500' (152 m)	
Ambient temperature	
Ambient temperature range for operation	-4°F to 104°F (-20°C to 40°C) Refer to Gear Box Specifications for appropriate oil types
Noise exposure	
Standard noise level	
(DB-A / 7 m) @ 3600 rpm	70 dBA



Detailed documentation for the motor can be obtained directly from Nord Gear Limited at www.nord.com/docs by supplying the model number and the serial number of the motor.

**Transport Platform with Car System
Motorized Unit Specifications**

Electrical Specifications	
Lifting power	18 HP
Power consumption (maximum load)	1 x 48A
Input power	240 VAC / 3 ph / 60 Hz (± 5%)
Control voltage	12 VDC
Starting current (peak)	Up to 290A
Power outlet for hand tool	1 x 220VAC/20A/60 Hz 1 x 120VAC/20A/60 Hz
Overall cable length up to 500' (152 m)	1 x 4/4 SOOW
Overall cable length from 500' (152 m) up to 800' (244 m)	1 x 2/4 SOOW

fig. 1.11

Gear Box Specifications (per gear box)		
Manufacturer	Nord Gear Limited	
Model	SK7382	
Oil 6.1 US gal (23 L) (for factory fill oil specifications refer to plate on gear boxes)	Ambient temperature 32°F to 104°F (0°C to 40°C)	Shell Omala S2G 220
		Mobilgear 600 XP220 (18,9 l)
	Ambient temperature -22°F to 140°F (-30°C to 60°C)	Shell Omala S4GX 220 (18,9 l)
		Mobilgear SHC 220
Maximum torque rate	55 630 lb-in (6285 N-m)	
Output RPM	8,7 rpm	

fig. 1.12

Motor Specifications (per motor)	
Manufacturer	Nord Gear Limited
Model	132S/4 CUS BRE100 RG
Rated power	7,5 HP (5,5 KW)
Service factor at full load	1,2
Rated amperage (nominal)	19,8A
Power supply – voltage, phase and frequency	240 VAC / 3 ph / 60 Hz
Rotation speed	1725 rpm
Braking torque	885 lb-in (100 N-m)
Power consumption of motor brake	85W
IP protection grade	IP65

fig. 1.13

Weight of Components			
UNIT and components		CAR and components	
Description	Weight	Description	Weight
S Series unit for TP application (as shipped)	4950 lb (2245 kg)	Transport platform car assembly	3560 lb (1615 kg)
Base and one full mast section	1210 lb (549 kg)	Rear extension assembly	385 lb (175 kg)
Base extension	275 lb (125 kg)	Lateral extension assembly	390 lb (177 kg)
Jack with adapter	50 lb (23 kg)	Guardrail 95" (241 cm)	70 lb (32 kg)
Mast guard (side)	30 lb (14 kg)	Guardrail 68" (173 cm)	51 lb (23 kg)
Mast guard (rear)	35 lb (16 kg)	Guardrail 20" (51 cm)	23 lb (10 kg)
Mast head (each)	32 lb (15 kg)	Rear (sliding) platform gate 10' (3 m) assembly	160 lb (73 kg)
Multiple mast handler	18 lb (8 kg)	Outrigger support assembly for TP car application	33 lb (16 kg)
		Front platform gate and ramp	350 lb (159 kg)
		Jib arm assembly	140 lb (64 kg)
		Jib arm top assembly	108 lb (49 kg)
		Jib arm bottom assembly	32 lb (15 kg)
		Rigid dual clamp	2.9 lb (1.3 kg)
		Swivel dual clamp	3.1 lb (1.4 kg)
		Wall tie bracket	2.2 lb (1 kg)
MAST and MAST TIES			
Description	Weight		
Mast assembly (1 rack)	330 lb (150 kg)		
Mast assembly (2 racks)	365 lb (166 kg)		
Mast tie frame	33 lb (15 kg)		
Mast tie 36" (91,5 cm)	16 lb (7 kg)		
Mast tie extension 36" (91,5 cm)	13 lb (6 kg)		
Mast tie extension 60" (1,5 m)	20 lb (9 kg)		

fig. 1.14

Dimensions of the Transport Platform with Car System

Top view

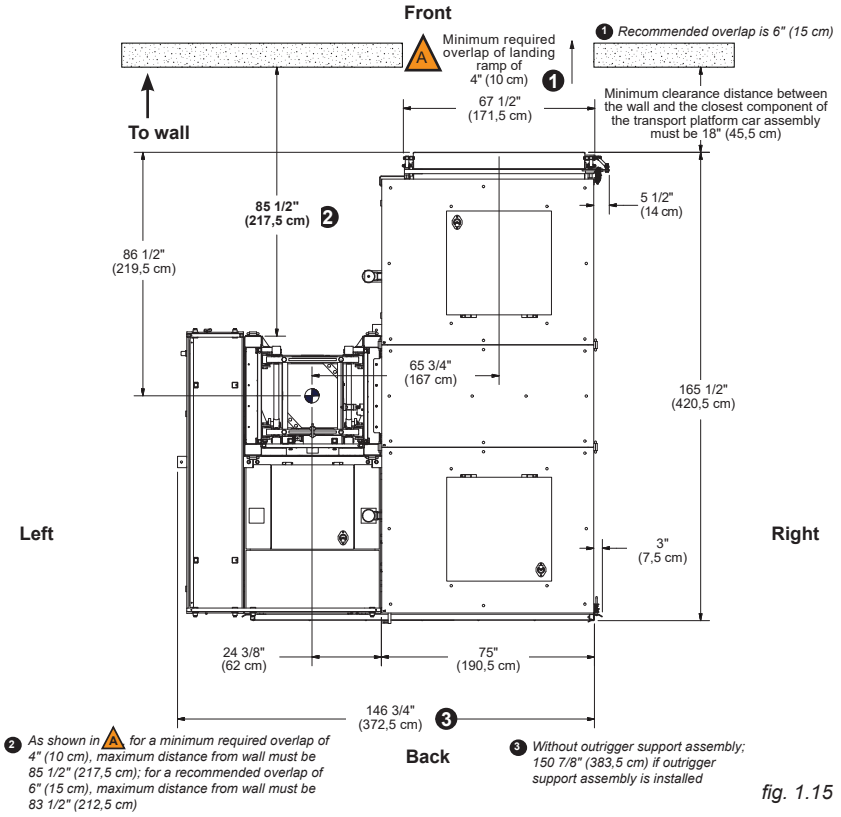

fig. 1.15

Rear view

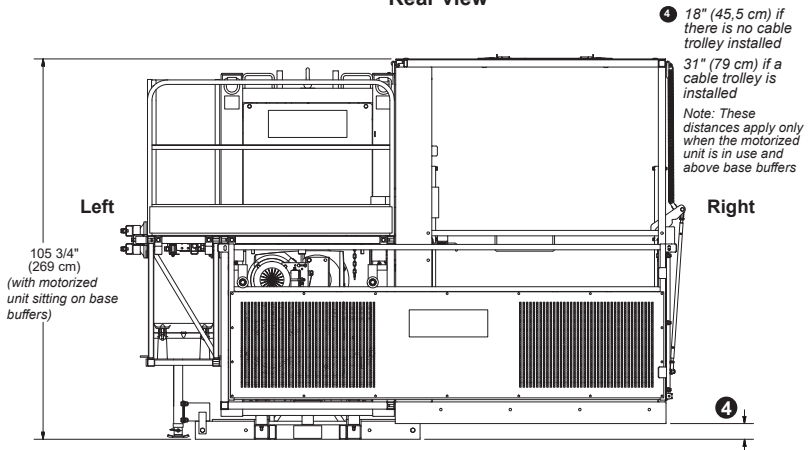

fig. 1.16

Transport Platform with Car System

Bearing surface

Before installing the motorized unit, make sure the bearing surface under it is level, clear of debris and has the proper bearing capacity. Appropriate cribbing must be placed under the base to distribute the load. It is important to make sure that the bearing surface is stable and has not been subject to any type of erosion or deterioration caused by weather conditions (snow, rain, etc.).

The type of cribbing chosen may vary according to the bearing surface where the setup must be installed.

For example, a setup installed on a concrete slab that is covering the bearing surface would require cribbing consisting of only one plywood panel under the base while a setup installed on a concrete slab that is covering an indoor garage would require shoring in addition to plywood cribbing.

A setup installed on a bearing surface composed of gravel, sand or any such type of surface would require stronger cribbing under the base.

In cases where shoring is required, it is recommended to contact an engineer for assistance.

Minimum Bearing Surface Capacities			
Height		Reaction	
ft	m	lb	kg
25	7,6	18 774	8516
50	15,2	20 591	9340
100	30,5	24 058	10 913
150	45,7	27 692	12 561
200	61	31 326	14 209
250	76,2	34 960	15 858
300	91,4	38 594	17 506
350	106,7	42 228	19154
400	121,9	45 862	20 803
450	137,2	49 496	22 451
500	152,4	53 130	24 099

Load reactions in table above include a dynamic factor

fig. 1.17

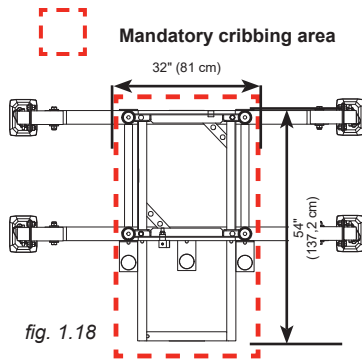

fig. 1.18

WARNING

Make sure the ground or support surface capacity meets with values included in the *Minimum Bearing Surface Capacities* table (fig. 1.17). Soil compacting, cribbing or shoring can increase bearing capacity. Any cribbing product or cribbing method approved by the site engineer can be used to distribute the load on the bearing surface providing it meets the values in the *Minimum Bearing Surface Capacities* table (fig. 1.17). Contact a licensed engineer for assistance.

Recommended cribbing for most bearing surfaces

The plywood and lumber used as cribbing must be secured together to prevent slipping.

Recommended Cribbing Pad		
60" x 40" x 6" (152,5 cm x 102 cm x 15,5 cm)		
①	Plywood 60" x 40" x 3/4" (152,5 cm x 102 cm x 2 cm)	2
②	Lumber 2" x 10" x 40" (5,5 cm x 25,5 cm x 102 cm)	12

fig. 1.19

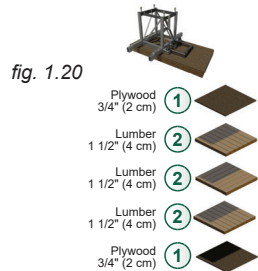

fig. 1.20

Values shown in the above table are for reference only. Any cribbing that covers the mandatory cribbing area and can evenly distribute the reaction load on the bearing surface (as shown in fig. 1.18) can be used.

Transport Platform with Car System

General Guidelines

The installation of an S Series transport platform with car system must be achieved through the **complete pre-installation of tie levels** (see box below).

It is **mandatory** to refer to the *Mast Tie Schedule* table on p. 70 of the *Mast and Mast Ties* section **before the installation of any S Series transport platform with car setup**.



The installation method described in this owner's manual is for a **right-side setup**. For the installation of a **left-side setup**, contact the Hydro Mobile technical team.

Definition of the pre-installation tie levels

The **pre-installation of tie levels**, referred to throughout this owner's manual and related documentation, consists in **installing all required tie levels up to the top of the installation before starting any work**, following the appropriate schedule of installation.

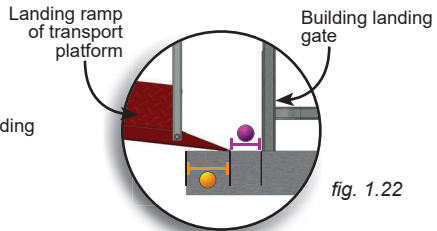
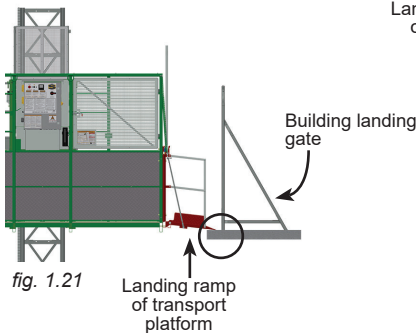
- 1- Installation must be carried out by **qualified erectors/dismantlers** under the supervision of a **competent person**, in accordance with all applicable local regulations. The use of fall protection is mandatory for erectors/dismantlers during the pre-installation of a setup. For the definition of a qualified erector/dismantler, refer to p. 7 of the *Performance and Safety* section. For information about fall protection, refer to p. 38 of the *Safety Devices* section.
- 2- In reference to the plan/layout drawing and job survey, determine if there are obstacles or hazards, what are the cribbing and tie requirements, and make sure that all the components required are available.
- 3- Establish the position of the transport platform system, taking into account that the minimum clearance between the front edge of the transport platform setup where the platform gate will be installed and the face of the work must be 18" (46 cm). The position must also take into account that the landing ramp needs to overlap the support point by a **recommended 6" (15 cm) or the minimum required of 4" (10 cm)**.
- 4- If the transport platform car will be used to carry material through an opening in a building, make sure that the width of each opening is **at least 68" (173 cm) and not more than 76" (193 cm)**, and that the support point for the overlap of the landing ramp has at least the same bearing capacity as the transport platform car.
- 5- Building landing gates must be installed at no more than 4" (10 cm) from the front edge of the ramp, as shown in fig. 1.22.



-  Recommended overlap of 6" (15 cm) or minimum required overlap of 4" (10 cm)
-  Installed at no more than 4" (10 cm) from front edge of landing ramp



NOTICE

If a standard S Series motorized unit is used, it is **mandatory** to refer to the instructions for removing the main frame. It must be noted that a **control pendant cannot be used with a standard S Series motorized unit control panel**.

Transport Platform with Car System

General Guidelines

- 6- If a standard S Series motorized unit is used, it **mandatory** to remove the main frame. For instructions on how to remove the main frame, refer to p. 35 of this section. It must be noted that a **control pendant cannot be used with a standard S Series motorized unit control panel**.
- 7- It is important to make sure that all four leveling jacks are installed on the base of the motorized unit. If a standard S Series motorized unit is used, it is **mandatory** to remove the base extensions and install the four leveling jacks for transport platform application directly on the base.

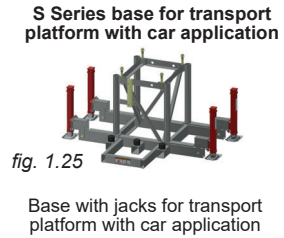
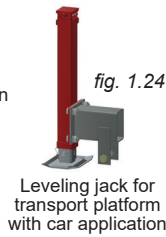
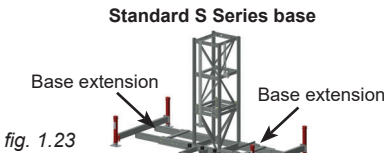

- 8- The use of an optional cable trolley kit is strongly recommended if the mast is higher than 150' (45,7 m). However, it must be noted that when the optional cable trolley is installed, the transport platform car will no longer lower all the way down to the base buffers, as clearance is required under the unit for the cable trolley installation, as shown in fig. 1.16, p. 13.
- 9- Before installing the motorized unit, determine where the cribbing under the base and its back extension will rest. The bearing surface under the cribbing must be level, clear of debris and have the proper bearing capacity (see the *Minimum Bearing Surface Capacities* table, fig. 1.17, p. 14). Should the actual bearing capacity be inferior to the values in the table, seek instructions and recommendations from the site engineer.
- 10- Lay down the cribbing and make sure it is level on both its front and side axis.
- 11- Unload the motorized unit with a rough terrain forklift or a crane. For more information on the lift and transport of an S Series motorized unit for transport platform car application, refer to p. 88 of the *Transport, Storage and Maintenance* section. It is important to consider that an S Series motorized unit for transport platform car application (without the extensions and the car) that must be lifted has a total weight of 4950 lb (2245 kg).
- 12- Proceed to the following instruction steps for the installation of the transport platform setup.



NOTICE

If an optional **cable trolley** is used, it must be noted that the transport platform car **will no longer lower all the way down to the base buffers**, as clearance is required under the unit for the cable trolley installation, as shown in fig. 1.40, p. 19.

Installation of the transport platform with car system – right side of the unit

This owner's manual for the S Series transport platform car provides the method to achieve a right-hand side configuration (right side of the unit). For instructions on how to achieve a left-hand side configuration, contact the Hydro Mobile technical team.

Positioning the motorized unit

- 1- Prepare the motorized unit and the area where the transport platform with car system will be installed, as described in the general guidelines on p. 15. Make sure all four leveling jacks are installed on the base.
- 2- Lift and align the base of the motorized unit with the face of the work and lower it into position. To achieve a **recommended** 6" (15 cm) overlap of the landing ramp or the **minimum** overlap **required** of 4" (10 cm) and proper seating of the landing ramp (fig. 1.21 and fig. 1.22, p. 15), the minimum clearance distance between the closest component of the transport platform car assembly and the face of the work must be 18" (46 cm). The distance between the face of the work and the front of the main trolley must be at least 83 1/2" (212,5 cm) but no more than 85 1/2" (217,5 cm). For more information about distances, refer to fig. 1.15, p. 13.

Transport Platform with Car System

Installation of the transport platform with car system – right side of the unit

Positioning the motorized unit (cont'd)

- Using the jacks on the base, plumb the mast on both its front and side axis, then, if required, use metal shims to make sure the base and its back extension sit squarely and level on the cribbing.

Installation of the first two tie levels



CAUTION

To avoid serious damages and possible injury, it is **mandatory** to install the first two tie levels before installing the extensions (rear and lateral) and the transport platform car. The **installation of the first two tie levels** must be done using **other means of access than the motorized unit**. The **motorized unit must rest on the buffers on the base until at least two** mast tie levels are completely installed.

- Pre-assemble a length of mast sections on the ground. The length of pre-assembled mast must be no longer than the number of mast sections required to reach the height at which the first tie level must be installed, according to the mast tie schedule. For more information about the schedule of installation of tie levels, refer to the *Mast Tie Schedule* table on p. 70 of the *Mast and Mast Ties* section.
- It is recommended to use the optional multiple mast handler to handle pre-assembled lengths of mast. For instructions on the use of the multiple mast handler, refer to p. 86 of the *Accessories* section.
- Using a crane (or a forklift) and the optional multiple mast handler, carefully lift and lower the pre-assembled length of mast on top of the mast section on the motorized unit. Still holding the length of mast, attach the bottom mast section to the top of the mast section already installed. Refer to p. 65 of the *Mast and Mast Ties* section for instructions on the assembly of mast sections.
- Still holding the newly installed length of mast**, install the first tie level. Refer to p. 71 of the *Mast and Mast Ties* section for instructions on how to install mast ties. Once the first tie level is in place, release the mast.

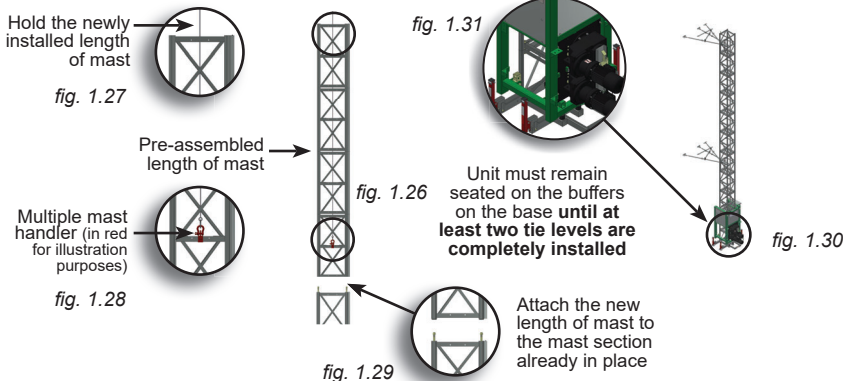

- Pre-assemble another length of mast sections on the ground. The length of pre-assembled mast must be no longer than the number of mast sections required to reach the height at which the second tie level must be installed, according to the mast tie schedule.
- Using a crane (or a forklift) and the optional multiple mast handler, carefully lift and lower the pre-assembled length of mast on top of the last mast section installed.
- Still holding the newly installed length of mast**, install the second tie level.
- The **motorized unit must remain seated on the buffers on the base**, so other means of access must be used to install the second tie level.

Transport Platform with Car System

Installation of the transport platform with car system – right side of the unit

Installation of the first two tie levels (cont'd)

- 12- Once the first two tie levels are in place, release the mast and remove the two leveling jacks and the adapters located on the right side (fig. 1.33). It is mandatory to remove the leveling jacks for transport platform with car application located on the right side of the base **before** installing the car assembly to avoid equipment damage and possible failure.

N

NOTICE

It is **mandatory** to remove the leveling jacks and adapters **before** installing the car assembly, as the jacks create an obstacle to the proper lowering of the car. Failure to remove the leveling jacks and adapters could result in equipment damage and possible failure.

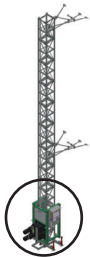

fig. 1.32

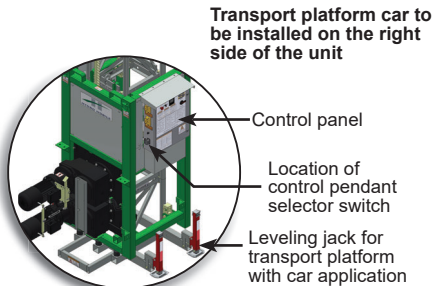

fig. 1.33

Control pendant selector switch must be turned to the left ("DIS") position to **disable** the control pendant

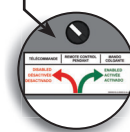

fig. 1.34

Control pendant selector switch

Connection of the unit and control panel to the power supply

- 13- Select a power cable appropriate for the installation. Refer to the *Power Cable Selection Chart* on p. 51 of the *Power Pack and Operating Components* section for help with the selection of the power cable. Make sure that the overall length of the cable is sufficient for the installation (height of mast, distance from power source, acceptable overall slack in cable).
- 14- Install and connect the power cable. **This installation must be performed by a certified electrician.** For instructions on the installation of the power cable, refer to p. 51 of the *Power Pack and Operating Components* section. It is important to note that if the optional cable trolley kit is required, it must only be installed once all the required tie levels have been installed up to the top of the mast. For instructions on the installation and use of the optional cable trolley kit, refer to p. 81 of the *Accessories* section.
- 15- Power up the control panel and the motorized unit. Refer to p. 53 of the *Control Panel* section for instructions on how to turn on the main power.
- 16- Make sure that the control pendant is **disabled** (the selector switch at the "DIS" position, as shown in fig. 1.34).

Adjusting and resetting the bottom final limit switch

- 17- On standard S Series motorized units bearing serial numbers S-0068 and up or S Series units manufactured specifically to be used in transport platform car applications, it is **mandatory** to reset and adjust the bottom final limit switch.
Failure to perform this adjustment will lock the motorized unit and prevent operation. For instructions on how to reset the bottom final limit switch, refer to p. 40 of the *Safety Devices* section.

N

NOTICE

On standard S Series motorized units bearing serial numbers S-0068 and up or S Series units manufactured specifically to be used in transport platform car applications, triggering the bottom final limit (BFL) or the top final limit (TFL) will cause a fault of the bottom (or top) final limit circuit: this will **lock the motorized unit and prevent operation**. In such a case, only a qualified erector/dismantler or a qualified technician can unlock the motorized unit.

Transport Platform with Car System

Installation of the transport platform with car system – right side of the unit

Installation of the extensions and the transport platform car

- 18- To avoid damages to equipment during the installation, it is important to remember that the **control pendant must not be connected** until the transport platform car has been installed.
- 19- Using the controls **directly on the control panel**, raise the motorized unit until it is about 1' (0,3 m) above the buffers on the base. It is important to proceed with caution when operating the controls directly on the control panel.
- 20- Install the rear extension (fig. 1.37, p. 19), then the lateral extension (fig. 1.39, p. 19) and then the transport platform car (fig. 1.41, p. 19). For instructions on the installation of the extensions and the transport platform car, refer to the *Transport Platform Car and Extensions* section on p. 45.

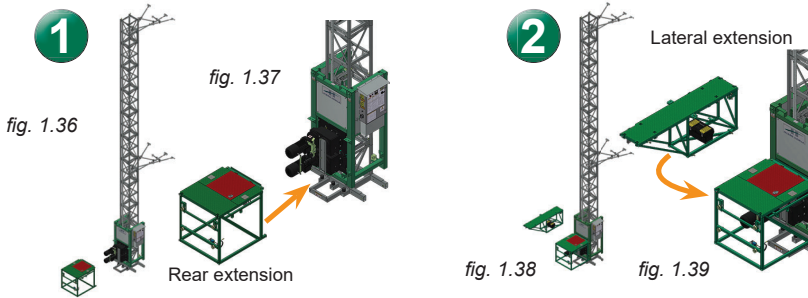

CAUTION

To avoid serious damages and possible injury, it is **mandatory** to install the first two tie levels before installing the extensions (rear and lateral) and the transport platform car. The **installation of the first two tie levels must be done using other means of access than the motorized unit. The motorized unit must rest on the buffers on the base until at least two** mast tie levels are completely installed.

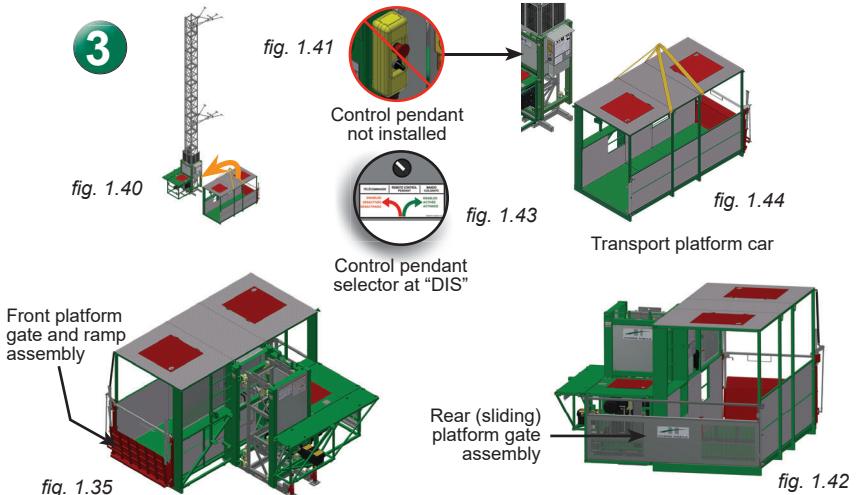

- 21- Install the rear (sliding) platform gate on the rear extension. For instructions on the installation and use of the rear (sliding) platform gate, refer to the *Transport Platform Car and Extensions* section on p. 47. Make sure that the rear (sliding) platform gate moves freely and locks properly.

Transport Platform with Car System

Installation of the transport platform with car system – right side of the unit

Installation of guardrails

- 22- Install the guardrails on the lateral and rear extensions. For instructions on the installation of guardrails on the extensions, refer to p. 48 of the *Transport Platform Car and Extensions* section.

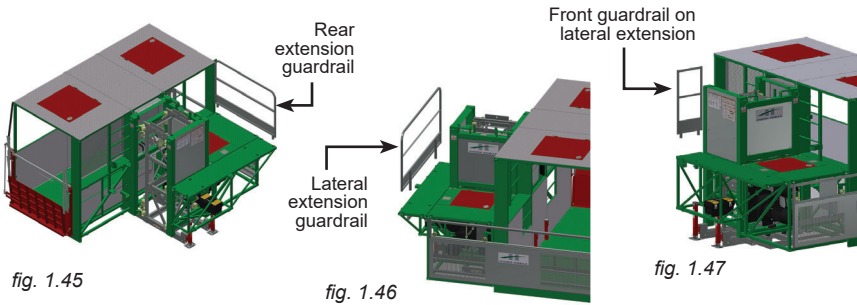

Connecting the gate sensors and the control pendant

- 23- Connect the rear and front platform gate sensors. For instructions on the connection of the gate sensors, refer to p. 40 of the *Safety Devices* section.
- 24- Connect the control pendant on the control panel. For instructions on the connection of the control pendant on the control panel, refer to p. 64 of the *Control Panel* section. Make sure that the control pendant is **enabled**. The selector switch must be at the “ENA” position, as shown in fig. 1.48.
- 25- If the unit used for the setup is a standard S Series motorized unit, it must be noted that a control pendant cannot be used.

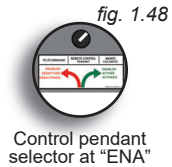

Installation of the safety stop

- 26- Install the safety stop. For instructions on the installation and use of the safety stop, refer to p. 38 of the *Safety Devices* section.



WARNING

It is **mandatory** to install the safety stop. This interruption allows the operator to make sure that there are no obstacles underneath the platform and that there is the necessary clearance to bring it down to base level.

Verification of switches, sensors and screen alerts

- 27- Review panel alerts and perform a verification of the switches and sensors, the gate sensors and the safety stop. For instructions on how to verify the switches and sensors, refer to p. 40 of the *Safety Devices* section.
- 28- Inspect the strobe under the main frame and make sure it is working appropriately.
- 29- If any of the switches or sensors is not working properly, the unit must be put out of service until it has been inspected and repaired by a qualified person. For more information about switches and sensors and their corresponding alerts, refer to p. 56 of the *Control Panel* section.

Installation of the mast tie installation deck

- 30- Install all the mast tie installation deck components **but not the planks**. Make sure that the mast tie installation deck support and the outrigger clear all obstacles. For instructions on the setup and use of the mast tie installation deck, refer to p. 48 of *Transport Platform Car and Extensions* section. The use of appropriate fall protection and proper tie points is **mandatory** for the qualified erectors/dismantlers during the pre-installation of tie levels. For more information about fall protection and tie points, refer to p. 38 of the *Safety Devices* section.

Transport Platform with Car System

Installation of the transport platform with car system – right side of the unit

Completing the installation of mast sections and tie levels

31- Once the first two tie levels are place, the transport platform can now be used to install the mast sections and tie levels required to complete the setup.

- It is **mandatory** to refer to the *Mast Tie Schedule* on p. 70 of the *Mast and Mast Ties* section to determine where the tie levels will be installed. It is important to make sure that the distance between tie levels is appropriate. For more information about height difference between tie levels, refer to p. 67 of the *Mast and Mast Ties* section.
- It is **mandatory** to choose the appropriate method to install mast sections and tie levels and to comply with the instructions of the selected method of installation of mast sections and tie levels.
- It is **mandatory** throughout the installation of mast sections and tie levels to **monitor the load** inside the transport platform car and on the extensions (rear and lateral). The **combined load** of the jib arm (if used), each mast section, all tie level components, each worker, each plank for the mast tie installation deck and any other item present on the transport platform **must be taken into account**.
- When reaching the height at which to install a tie level and after having installed the last mast section, it is **important** to make sure that the **load inside the transport platform car and on the rear and lateral extensions never exceeds the maximum E&D load of 1500 lb (680 kg)** (workers, tools, mast sections, components for a tie level, jib arm, planks for the mast tie installation deck, and any other item present on the platform) to reduce mast deflection from plumbness and minimize stress on ties and mast assembly.

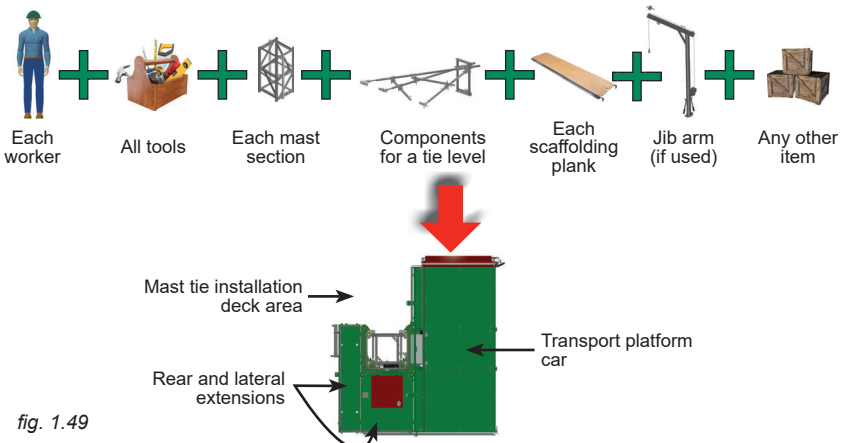

LOAD ON TRANSPORT PLATFORM DURING INSTALLATION

32- The mast sections and tie levels can be installed following two methods of installation:

- by loading mast sections and mast tie components inside the transport platform car
- by using pre-assembled lengths of mast sections and loading mast tie level components inside the transport platform car

For instructions on the installation of mast sections and tie levels **using the transport platform car**, refer to p. 23 of this section. Refer to p. 25 for instructions on the installation of tie levels and **mast sections in pre-assembled lengths**.

33- Proceed with the installation of as many mast sections and tie levels as is required by the layout plan and the configuration. The S Series transport platform with car system must not be used on a mast with a height over 500' (152 m). To maximize efficiency and because of the speed of travel, it is recommended to use the S Series transport platform with car system on a mast with a height of 200' (61 m) or less.



WARNING

It is mandatory to **install all required tie levels** up to the top of the installation **before** starting any work, following the schedule of installation. Failure to install all tie levels as required by the mast tie schedule for an S Series transport platform with car application before starting any work could compromise the integrity of the installation, leading to serious injury or death.

Transport Platform with Car System

Installation procedure for right side of the unit

Installation of the last mast section and the mast heads

- 34- Once the installation of mast sections and tie levels is complete, install the two mast heads on top of the last mast section, making sure to install the mast head with the shackle at the **rear** position, as shown in fig. 1.53. Tighten all bolt assemblies with a torque of 150 lb-ft (203 N-m) If mast heads are not used, make sure that the last mast section installed has **no rack** or only **one rack** that is **toward the face of the work**.

Installing the top limit trigger plate and testing the top limit sensor

- 35- Install the top limit trigger plate (fig. 1.50) at the top of the work where traveling on the mast must end. Bolt the trigger plate on the middle bar of the next to last mast section (fig. 1.51), on the same side as the control panel. Make sure that the trigger is facing toward the rear of the mast, as shown in fig. 1.51.

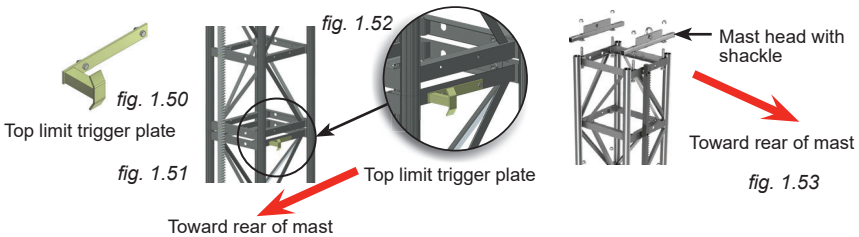

- 36- Test the operation of the top limit sensor. For instructions on how to verify the switches and sensors, refer to p. 40 of the *Safety Devices* section. Adjust the position of the sensor, if necessary. If the limit sensor is not working properly, the unit must be put out of service until it has been inspected and repaired by a qualified person. For the definition of a qualified person, refer to p. 7 of the *Performance and Safety Rules* section. For more information about limit sensors and their corresponding alerts, refer to p. 56 of the *Control Panel* section.

Removing mast tie deck components

- 37- Bring the motorized unit down to base level.
 38- Remove all the mast tie installation deck components. For instructions on the removal of mast tie deck components, refer to p. 49 of the *Transport Platform Car and Extensions* section.
 39- Make sure all access panels on top of the transport platform car are closed.

Installation of the cable trolley kit (optional)

- 40- If required, install the optional cable trolley kit. For instructions on the installation and use of the cable trolley kit, refer to p. 81 of the *Accessories* section.

Installation of the movable buffer assembly (optional)

- 41- If required, install the movable buffer assembly. For instructions on the installation and use of the movable buffer assembly, refer to p. 84 of the *Accessories* section.

Greasing of the racks and gears

- 42- **Upon initial setup and subsequently after every eight to ten hours of cumulative runtime** (unit travel up and down the mast), grease must be applied to the gears, and to the rack(s) from the top of the mast down. For more information, refer to the daily inspection checklist recommended for this motorized unit. Use an open gear lubricant recommended by Hydro Mobile. If an **aerosol open gear lubricant** is used, **grease must be allowed to stand for 2-3 hours** before the motorized unit is used again. Refer to p. 91 of the *Transport, Storage and Maintenance* section for more information on the appropriate lubrication method. Lower the motorized unit to base level, verifying the mast ties and the mast bolts and applying grease, as required, on the way down. Make sure that all bolt assemblies are properly secured and in good condition and that grease is applied appropriately.

Installation of mast guards

- 43- Once the rack and gears have been properly greased, install the mast guards. Tighten all bolt assemblies with a torque of 30 lb-ft (41 N-m).

Transport Platform with Car System

Installation procedure for right side of the unit

Verification of the setup

- 44- Make a final verification of the setup before passing the installation for use. Make sure all the guardrails on the extensions (rear and lateral), platform gates and landing level gates are in place and secure. In all cases where workers are exposed to fall hazards greater than specified by local regulations, the installation of guardrails is **mandatory**.
- 45- Before authorizing workers to use the motorized unit, perform every step in the daily inspection checklist. It is recommended to fill out the handover sheet to complete the installation. Refer to p. 91 of the *Transport, Storage and Maintenance* section for more information about the daily inspection checklist and to p. 94 for information about the handover sheet.



CAUTION

It is essential to make sure that the floor of the transport platform car has the proper bearing capacity.

Installation of mast sections and tie levels using the transport platform car

The installation of mast sections and tie levels must be performed by **qualified erectors/dismantlers**. For the definition of a qualified erector/dismantler, refer to p. 7 of the *Performance and Safety Rules* section.

The transport platform car can be used to carry the mast sections and mast tie components required to complete the installation of mast sections and tie levels to the top of the work. Only the **exact number of mast sections required to reach the height at which to install the next tie level** and the mast tie components required for that tie level must be loaded in the transport platform car **at a time**. When reaching the height at which to install a tie level, it is also important to make sure that the **load inside the transport platform car and on the rear and lateral extensions never exceeds the maximum E&D load of 1500 lb (680 kg)** (workers, tools, mast sections, components for a tie level, jib arm, planks for the mast tie installation deck, and any other item present on the platform).

As the mast sections are installed, the weight on the transport platform lessens, reducing mast deflection from plumbness and minimizing stress in ties and mast assembly.

- 1- Make sure mast guards and mast heads are removed.
- 2- Make sure the mast tie installation deck is installed.
- 3- With the motorized unit at base level, load only the exact number of mast sections required to reach the height at which to install the next tie level, according to the *Mast Tie Schedule* on p. 70 of the *Mast and Mast Ties* section, and the mast tie components necessary for that tie level into the transport platform car.

Mast sections must be loaded with care and stored properly inside the transport platform car to avoid damages to the racks.

Evolution of the load on the transport platform when installing a typical 30' (9,1 m) tie distance installation

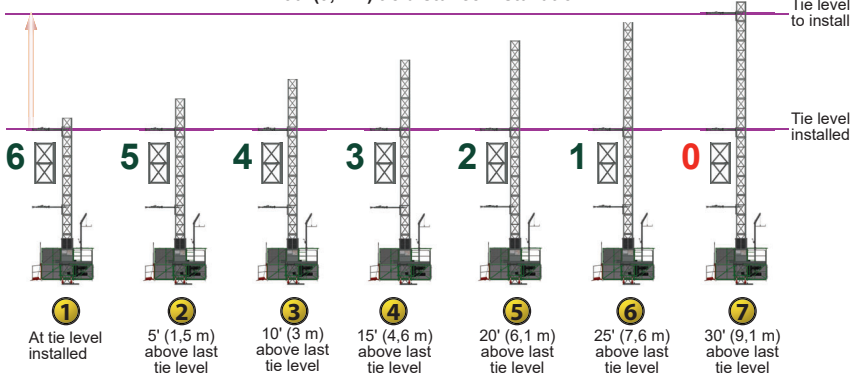

fig. 1.54

Transport Platform with Car System

Installation procedure for right side of the unit

Installation of mast sections and tie levels using the transport platform car

Evolution of the load on the transport platform when installing a typical 30' (9,1 m) tie distance installation

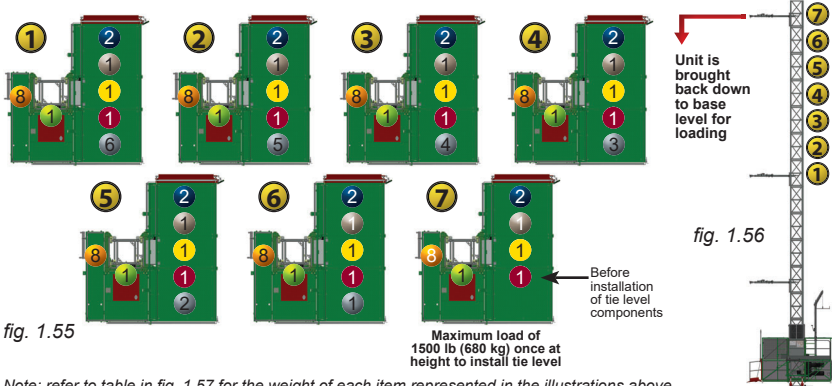

fig. 1.55

Note: refer to table in fig. 1.57 for the weight of each item represented in the illustrations above

Description	Weight	1	2	3	4	5	6	7
One-rack mast section	330 lb (150 kg)	1980 lb (898 kg)	1650 lb (748 kg)	1320 lb (599 kg)	990 lb (449 kg)	660 lb (299 kg)	330 lb (150 kg)	0
Components for one tie level	250 lb (113 kg)	250 lb (113 kg)	250 lb (113 kg)	250 lb (113 kg)	250 lb (113 kg)	250 lb (113 kg)	250 lb (113 kg)	250 lb (113 kg)
Scaffold steel plank	30 lb (14 kg)	240 lb (109 kg)	240 lb (109 kg)	240 lb (109 kg)	240 lb (109 kg)	240 lb (109 kg)	240 lb (109 kg)	240 lb (109 kg)
Jib arm	140 lb (64 kg)	140 lb (64 kg)	140 lb (64 kg)	140 lb (64 kg)	140 lb (64 kg)	140 lb (64 kg)	140 lb (64 kg)	140 lb (64 kg)
Worker	265 lb (120 kg)	530 lb (240 kg)	530 lb (240 kg)	530 lb (240 kg)	530 lb (240 kg)	530 lb (240 kg)	530 lb (240 kg)	530 lb (240 kg)
Installation tools	200 lb (91 kg)	200 lb (91 kg)	200 lb (91 kg)	200 lb (91 kg)	200 lb (91 kg)	200 lb (91 kg)	200 lb (91 kg)	200 lb (91 kg)
Total for installation of mast sections and tie level		3340 lb (1515 kg)	3010 lb (1365 kg)	2680 lb (1216 kg)	2350 lb (1066 kg)	2020 lb (916 kg)	1690 lb (767 kg)	1360 lb (617 kg)
Maximum weight allowed for other items								140 lb (64 kg)
TOTAL LOAD ON PLATFORM		3480 lb (1579 kg)	3150 lb (1429 kg)	2820 lb (1343 kg)	2490 lb (1129 kg)	2160 lb (980 kg)	1830 lb (830 kg)	1500 lb (680 kg)

fig. 1.57

- Make sure that the planks on the mast tie installation deck are not in place and that the telescopic plank support tube and the outrigger clear all obstacles. Raise the motorized unit to where the next mast section must be installed.
- Open the rear access panel on top of the transport platform car (fig. 1.1, p. 10).
- Using an optional jib arm, retrieve a mast section from the transport platform car. For more information about the installation and use of the jib arm, refer to p. 77 of the Accessories section.
- Install mast sections until a tie level is required (steps, 1, 2, 3, 4, 5 and 6 in fig. 1.56).

NOTICE

When reaching the height at which to install a tie level and after having installed the mast section, it is important to make sure that the load inside the transport platform car and on the rear and lateral extensions never exceeds 1500 lb (680 kg) (workers, tools, mast sections, components for a tie level, material, etc.) to reduce mast deflection from plumbness and minimize stress on ties and mast assemblies.

CAUTION

Before raising or lowering the motorized unit during pre-installation, **make sure that the planks on the mast tie installation deck are not in place** and that the telescopic plank support tube and the outrigger clear all obstacles.

Transport Platform with Car System

Installation procedure for right side of the unit

Installation of mast sections and tie levels using the transport platform car

- 8- When reaching the height at which to install a tie level and once the mast section is in place, the **load inside the transport platform car and on the rear and lateral extensions must not exceed the maximum E&D load of 1500 lb (680 kg)** (workers, tools, mast sections, components for a tie level, jib arm, planks for the mast tie installation deck, and any other item present on the platform).
- 9- Install the planks for the mast tie deck and install the tie level.
- 10- Make sure to **remove the planks of the mast tie deck** and make sure that the telescopic plank support tube and the outrigger clear all obstacles. Bring the transport platform back to base level. If required, load only the exact number of mast sections to reach the height at which to install the next tie level and the mast tie components required for that tie level into the transport platform car.
- 11- Repeat steps 4 through 10 to install as many mast sections and tie levels as required by the layout plan and as is allowed. Any S Series transport platform car setup must not be used on mast with a height over 500' (152 m). To maximize efficiency and because of the speed of travel, it is recommended to use the S Series transport platform with car system on a mast with a height of 200' (61 m) or less.
- 12- Once all required mast sections and tie levels are in place, bring the motorized unit to base level, close the rear access panel on top of the transport platform car and remove the jib arm.

N	NOTICE
<p>It is important to refer to and follow the guidelines of the selected method of installation (loading of mast sections inside the car or using pre-assembled lengths of mast). The installation of mast sections and tie levels must be performed by qualified erectors/dismantlers.</p>	

Installation of pre-assembled lengths of mast sections and tie levels

The installation of mast sections and tie levels must be performed by **qualified erectors/dismantlers**. For the definition of a qualified erector/dismantler, refer to p. 7 of the *Performance and Safety Rules* section.

The installation of mast sections can be achieved by using pre-assembled lengths of mast (also referred to as “sticks”). The use of the optional multiple mast handler is recommended to install these pre-assembled lengths of mast. For instructions on the installation and use of the multiple mast handler, refer to p. 86 of the *Accessories* section.

The maximum length of pre-assembled mast allowed is equal to the exact number of mast sections required to reach the height at which to install the next tie level, according to the *Mast Tie Schedule*, on p. 70 of the *Mast and Mast Ties* section.

It is also important to make sure that the **load inside the transport platform car and on the rear and lateral extensions never exceeds the maximum E&D load of 1500 lb (680 kg)** (workers, tools, mast sections, components for a tie level, planks for the mast tie installation deck, and any other item present on the platform) during the pre-installation of tie levels to reduce mast deflection from plumbness and minimize stress on ties and mast assembly.

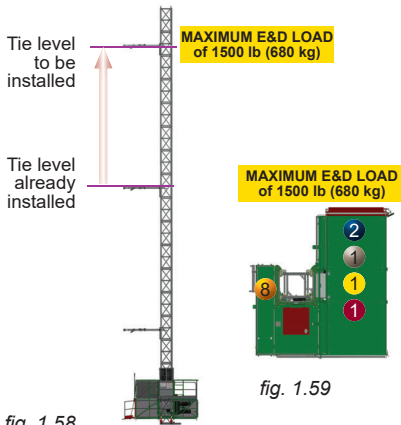

fig. 1.59

fig. 1.58

Description	Weight	Load
● One-rack mast section	330 lb (150 kg)	0
● Components for one tie level	250 lb (113 kg)	250 lb (113 kg)
● Scaffold steel plank	30 lb (14 kg)	240 lb (109 kg)
● Jib arm	140 lb (64 kg)	0
● Worker	265 lb (120 kg)	530 lb (240 kg)
● Installation tools	200 lb (91 kg)	200 lb (91 kg)
Total for installation of mast sections and tie level		1220 lb (553 kg)
● Maximum weight allowed for other items		280 lb (127 kg)
TOTAL LOAD ON PLATFORM		1500 lb (680 kg)

fig. 1.60

Transport Platform with Car System

Installation procedure for right side of the unit

Installation of pre-assembled lengths of mast sections and tie levels

- 1- Make sure that the mast guards and the two mast heads are removed.
- 2- Make sure the mast tie installation deck is installed.
- 3- Make sure that the planks on the mast tie installation deck are not in place. Raise the motorized unit to where the next mast section must be installed.
- 4- Using a crane (or a forklift) and the optional multiple mast handler, carefully lift and lower the pre-assembled length of mast on top of the last mast section installed. Refer to p. 65 of the *Mast and Mast Ties* section for instructions on the assembly of mast sections,. For instructions on the installation and use of the multiple mast handler, refer to p. 86 of the *Accessories* section.
- 5- Still holding the length of mast, attach the bottom mast section to the top of the mast section already installed. Tighten all bolts to 150 lb-ft (203 N-m).
- 6- Raise the motorized to the height where the tie level must be installed.
- 7- Install the planks for the mast tie deck and install the tie level.
- 8- Make sure to **remove the planks of the mast tie deck** and make sure that the telescopic plank support tube and the outrigger clear all obstacles.
- 9- Repeat steps 4 through 8 to install as many mast sections and tie levels as required by the layout plan and as is allowed. Any S Series transport platform car setup must not be used on mast with a height over 500' (152 m). To maximize efficiency and because of the speed of travel, it is recommended to use the S Series transport platform with car system on a mast with a height of 200' (61 m) or less.



WARNING

It is **critical** to make sure that all components installed (lateral and rear extensions, transport platform car) remain in place **at all times** until the setup is dismantled. A transport platform with car installation that does not have all its components in place must not be used until it has been inspected and repaired by a qualified person.



CAUTION

It is essential to always make sure that the floor of the transport platform car has the proper bearing capacity.

Dismantling a transport platform with car system – right side of the unit

SAFETY comes first. It is essential that the **dismantling** of an S Series transport platform with car setup be carried out by **qualified erectors/dismantlers** under the supervision of a **competent person** and be performed with the same care and precaution taken during the installation. The use of fall protection is mandatory for erectors/dismantlers during the dismantling of a setup.

This owner's manual for the S Series transport platform car provides the method to dismantle a right-hand side configuration (right side of the unit). For instructions on how to dismantle a left-hand side configuration, contact the Hydro Mobile technical team.

It is mandatory to make sure that the motorized unit installation remains stable and secure throughout the dismantling maneuvers. For the definition of a qualified erector/dismantler or a competent person, refer to p. 7 of the *Performance and Safety* section.

Safety guidelines for dismantling a transport platform with car installation

- 1- Make sure all loads have been removed from the transport platform car.
- 2- Make sure all the equipment necessary for a safe dismantling of the installation is on hand (slings, crane or rough terrain forklift, etc., as required).

Preparing the installation for dismantling

- 1- Fill out the job survey and hazard analysis form. For more information about the job survey form, refer to p. 94 of the *Transport, Storage and Maintenance* section.
- 2- If required, remove the movable buffer assembly. For instructions on the removal of the movable buffer assembly, refer to p. 84 of the *Accessories* section.

Transport Platform with Car System

Dismantling procedure for right side of the unit

Preparing the installation for dismantling

- 3- If required, remove the optional cable trolley kit and its components. For instructions on the removal of the cable trolley kit, refer to p. 81 of the *Accessories* section.
- 4- Inspect all safety devices (emergency descent, safety stop, safety gates, etc.) and make sure that they are working properly.
- 5- Perform every step in the daily inspection checklist. Refer to p. 91 of the *Transport, Storage and Maintenance* section for more information about the daily inspection checklist.
- 6- Make sure that the mast guards are removed.
- 7- Install all the mast tie installation deck components **but not the planks**. Make sure that the mast tie installation deck support and the outrigger clear all obstacles. For instructions on the setup and use of the mast tie installation deck, refer to p. 48 of *Transport Platform Car and Extensions* section. The use of appropriate fall protection and proper tie points is **mandatory** for the qualified erectors during the dismantling of tie levels. For more information about fall protection and tie points, refer to p. 38 of the *Accessories* section.

Removal of the mast heads and the top limit trigger plate

- 8- Bring the motorized unit to the top of the work, verifying mast bolts and mast ties on the way up. Make sure that all mast bolts are tightened appropriately and that all mast ties are properly tied to the face of the work.
- 9- Remove the mast heads and the top limit trigger plate from the middle bar of the next to last mast section.

Removal of tie levels and mast sections

- 10- The removal of all mast sections and tie levels must be performed with caution.
 - It is **mandatory** to choose the appropriate method to remove tie levels and mast sections and to comply with the instructions of the selected method of removal of tie levels and mast sections.
 - It is **mandatory** throughout the removal of tie levels and mast sections to **monitor the load** inside the transport platform car and on the extensions (rear and lateral). The **combined load** of the jib arm (if used), each mast section, all tie levels components, each worker, each plank for the mast tie installation deck and any other item present on the transport platform **must be taken into account**.
 - When at the height at which to remove a tie level, it is **important** to make sure that before removing that tie level and the mast section, the **load inside the transport platform car and on the extensions (rear and lateral) does not exceed the maximum E&D load of 1500 lb (680 kg)** (workers, tools, mast sections, components for a tie level, jib arm, planks for the mast tie installation deck, and any other item present on the platform) to reduce mast deflection from plumbness and minimize stress on ties and mast assembly.

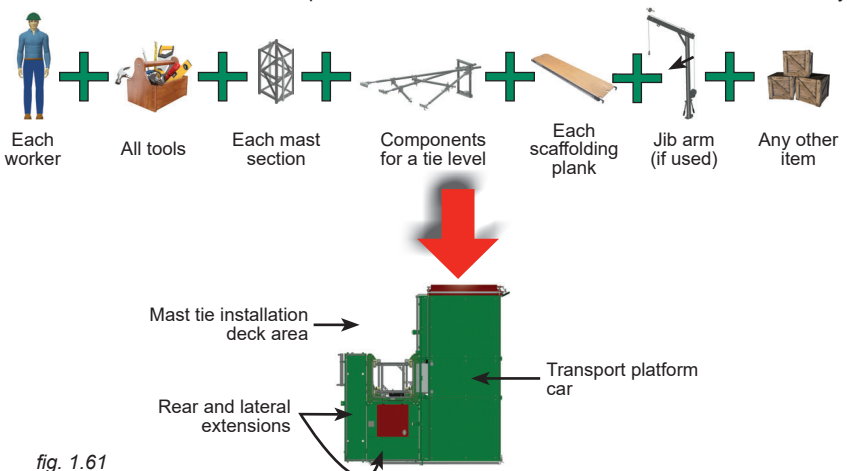

fig. 1.61

LOAD ON TRANSPORT PLATFORM DURING DISMANTLING

Transport Platform with Car System

Dismantling procedure for right-hand side of the unit

Removal of tie levels and mast sections (cont'd)

- 11- All mast sections and tie levels, **except for the last two tie levels**, can be removed following two methods of removal
- by loading the removed mast tie components and mast sections inside the transport platform car
 - by loading the removed mast tie components inside the transport platform car and removing the mast sections in assembled lengths (also referred to as "sticks")
- For instructions on the removal of tie levels and mast sections **using the transport platform car**, refer to p. 30 of this section. Refer to p. 32 for instructions on the removal of tie levels and **mast sections in pre-assembled lengths**.
- 12- Remove all tie levels and mast sections, **leaving the last two tie levels in place**.

	CAUTION
<p>When only two tie levels are remaining, it is important to proceed with extreme care to make sure that the stability of the motorized unit is not compromised during the operation.</p> <p>Before removing the last two tie levels, it is imperative to:</p> <ul style="list-style-type: none"> • bring the motorized unit down to the base buffers; the motorized unit is no longer allowed to travel up and down the mast • make sure that the transport platform car and the rear and lateral extensions are removed • make sure that the leveling jacks are all in place (reinstalled on the right side of the base) 	

Removing guardrails and gates

- 13- Remove the guardrails from each extension (rear and lateral) and set them aside.
- 14- Disconnect the gate sensors and store the cables properly.
- 15- Disconnect the control pendant and store it properly.
- 16- Remove the sliding gate and set it aside.
- 17- Make sure the front gate of the transport platform car is secured properly.

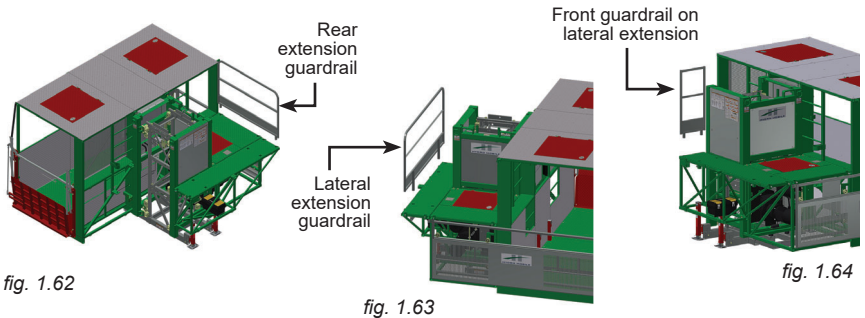

Removing the transport platform car and the extensions (rear and lateral)

- 18- Bring the motorized unit down until it is about 12" (30,5 cm) above the base buffers.
- 19- Shut down the motorized unit and disconnect the control pendant. For instructions on how to shut down the motorized unit, refer to p. 52 of the *Power Pack and Operating Components* section. Refer to p. 64 of the *Control Panel* section for instructions on how to disconnect the control pendant.

	CAUTION
<p>It is mandatory to re-install the two leveling jacks and adapters on the right-hand side of the base. Failure to re-install the leveling jacks will cause the motorized unit to become unstable once all mast ties are removed, resulting in equipment damage and possible injury.</p>	

Transport Platform with Car System

Dismantling procedure for right-hand side of the unit

Removing the transport platform car and the extensions (rear and lateral) (cont'd)

- 20- Remove the transport platform car ("1" in fig. 1.65). For instructions on the lifting and moving of the transport platform car, refer to p. 88 of the *Transport, Storage and Maintenance* section.
- 21- Remove the outrigger support from the lateral extension.
- 22- Remove the lateral extension ("2" in fig. 1.65) and the rear extension ("3" in fig. 1.65).
- 23- Once the extensions and the transport platform car are removed, re-install the two leveling jacks on the right-hand side of the base ("4" in fig. 1.65). Make sure all four jacks are in place.
- 24- Store the guardrails, platform extensions (rear and lateral) and sliding gate inside the transport platform car. Refer to p. 90 of the *Transport, Maintenance and Storage* section for instructions on the storage of the extensions, the sliding gate and the guardrails.

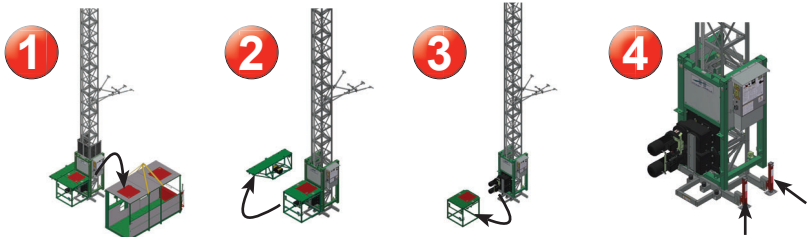

fig. 1.65

N	NOTICE
It is important to make sure that the control pendant has been disconnected before removing the transport platform car.	

Removal of the last two tie levels and the last mast sections

- 25- **Using the emergency descent system, lower the motorized unit down to the base buffers.** For instructions on the use of the emergency descent system, refer to p. 37 of the *Safety Devices* section.
- 26- Disconnect the power cable from the motorized unit and from the power source. **This operation must be performed by a certified electrician.** Store the power cable properly.
- 27- Make sure the installation is stable and proceed with the removal of the next-to-last tie level. **The motorized unit must remain seated on the buffers on the base, other means of access must be used.**
- 28- **With the help of a crane or any other appropriate lifting device,** remove all mast sections installed above the last tie level. To facilitate the removal of those mast sections, it is recommended to remove them assembled together and to handle them with the optional multiple mast handler. For instructions on the use of the optional multiple mast handler, refer to p. 86 of the *Accessories* section.
- 29- Make sure the installation is stable and proceed with the removal of the last tie level.
- 30- **With the help of a crane or any other appropriate lifting device,** remove all remaining mast sections.
- 31- Install the two mast heads.
- 32- If the unit used for the transport platform car installation is a standard S Series unit, reinstall the main frame on the motorized unit. For instructions on how to reinstall the main frame, refer to p. 35 of this section.
- 33- If the unit is to be stored for any significant length of time, refer to p. 90 of the *Transport, Storage and Maintenance* section for instructions on how to properly store an S Series motorized unit for transport platform with car application.

Transport Platform with Car System

Dismantling procedure for right-hand side of the unit

Removal of mast sections and tie levels using the transport platform car

The removal of mast sections and tie levels must be performed by **qualified erectors/dismantlers**. For the definition of a qualified erector/dismantler, refer top. 7 of the *Performance and Safety Rules* section.

The transport platform car can be used to carry mast sections and tie level components when dismantling the installation.

Only the tie components of the tie level to be removed and the exact number of mast sections required to remove to reach the following tie level (lower) must be loaded in the transport platform car. Consequently, when the transport platform is at the height at which the tie level must be removed, it is important to make sure that the **load inside the transport platform car and on the rear and lateral extensions never exceeds the maximum E&D load of 1500 lb (680 kg)** (workers, tools, mast sections, components for a tie level, jib arm, planks for the mast tie removal deck, and any other item present on the platform).

As the mast sections are removed from the setup, the weight on the transport platform builds up, increasing mast deflection from plumbness and intensifying stress in ties and mast assembly.

Evolution of the load on the transport platform when dismantling a typical 30' (9,1 m) tie distance installation

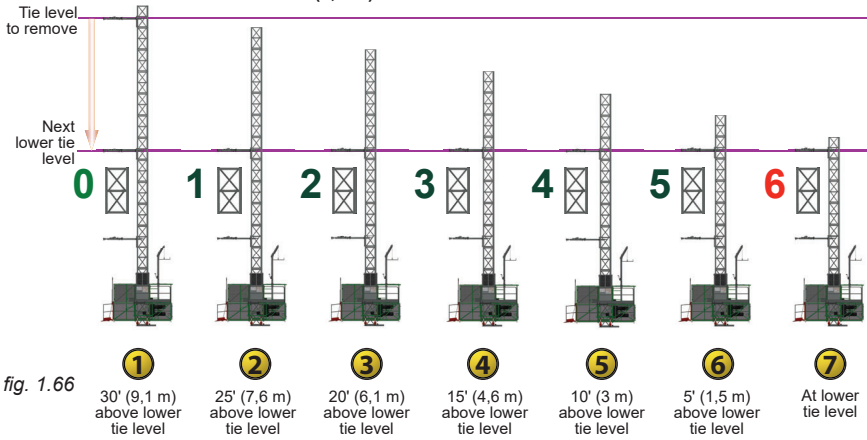

fig. 1.66

Note: refer to table in fig. 1.69, p. 31 for the weight of each item represented in the illustrations below

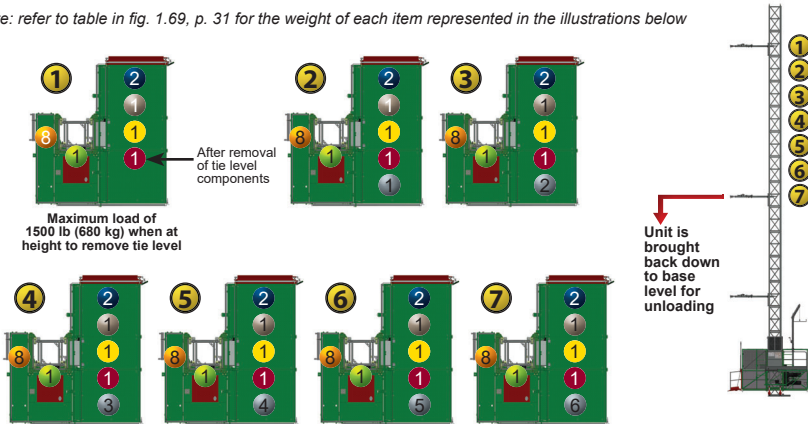

fig. 1.67

fig. 1.68

Transport Platform with Car System

Dismantling procedure for right-hand side of the unit

Removal of mast sections and tie levels using the transport platform car

Evolution of the load on the transport platform when dismantling a typical 30' (9,1 m) tie distance installation

Description	Weight	①	②	③	④	⑤	⑥	⑦
● One-rack mast section	330 lb (150 kg)	0	330 lb (150 kg)	660 lb (299 kg)	990 lb (449 kg)	1320 lb (599 kg)	1650 lb (748 kg)	1980 lb (898 kg)
● Components for one tie level	250 lb (113 kg)	250 lb (113 kg)	250 lb (113 kg)	250 lb (113 kg)	250 lb (113 kg)	250 lb (113 kg)	250 lb (113 kg)	250 lb (113 kg)
● Scaffold steel plank	30 lb (14 kg)	240 lb (109 kg)	240 lb (109 kg)	240 lb (109 kg)	240 lb (109 kg)	240 lb (109 kg)	240 lb (109 kg)	240 lb (109 kg)
● Jib arm	140 lb (64 kg)	140 lb (64 kg)	140 lb (64 kg)	140 lb (64 kg)	140 lb (64 kg)	140 lb (64 kg)	140 lb (64 kg)	140 lb (64 kg)
● Worker	265 lb (120 kg)	530 lb (240 kg)	530 lb (240 kg)	530 lb (240 kg)	530 lb (240 kg)	530 lb (240 kg)	530 lb (240 kg)	530 lb (240 kg)
● Installation tools	200 lb (91 kg)	200 lb (91 kg)	200 lb (91 kg)	200 lb (91 kg)	200 lb (91 kg)	200 lb (91 kg)	200 lb (91 kg)	200 lb (91 kg)
Total for installation of mast sections and tie level		1360 lb (617 kg)	1690 lb (767 kg)	2020 lb (916 kg)	2350 lb (1066 kg)	2680 lb (1216 kg)	3010 lb (1365 kg)	3340 lb (1515 kg)
● Maximum weight allowed for other items	140 lb (64 kg)	→						
TOTAL LOAD ON PLATFORM		1500 lb (680 kg)	1830 lb (830 kg)	2160 lb (980 kg)	2490 lb (1129 kg)	2820 lb (1343 kg)	3150 lb (1429 kg)	3480 lb (1579 kg)

fig. 1.69

- 1- Prepare the installation as described in the safety guidelines and the preparation instructions on p. 26 of this section.
- 2- Bring the motorized unit to where the tie level must be removed.
- 3- Make sure that the planks on the mast tie installation deck are into place.
- 4- Remove the tie level. For instructions on how to remove a tie level, refer to p. 73 of the *Mast and Mast Ties* section.

**CAUTION**

It is **mandatory** to make sure that **all tension (or compression) is released** from the mast tie before attempting to unpin it from the wall tie.

- 5- Open the rear access panel on top of the transport platform car.
- 6- Using an optional jib arm, remove the mast section and load it carefully inside the transport platform car. For instructions on how to remove mast sections, refer to p. 66 of the *Mast and Mast Ties* section. For more information about the installation and use of the jib arm, refer to p. 77 of the *Accessories* section.
Mast sections must be loaded with care and stored properly inside the transport platform car to avoid damages to the racks.
- 7- Make sure to **remove the planks of the mast tie deck**. Make sure that the telescopic plank support tube and the outrigger clear all obstacles. Lower the motorized unit to where the next mast section must be removed.
- 8- Repeat step 6 to remove mast sections until the next lower tie level is reached. Make sure to **leave that lower tie level in place**.

**NOTICE**

When reaching the height at which to install a tie level and after having installed the mast section, it is important to make sure that the load inside the transport platform car and on the rear and lateral extensions never exceeds 1500 lb (680 kg) (workers, tools, mast sections, components for a tie level, material, etc.) to reduce mast deflection from plumbness and minimize stress on ties and mast assemblies.

**CAUTION**

Before raising or lowering the motorized unit during dismantling, **make sure that the planks on the mast tie installation deck are not in place** and that the telescopic plank support tube and the outrigger clear all obstacles.

Transport Platform with Car System

Dismantling procedure for right-hand side of the unit

Removal of mast sections and tie levels using the transport platform car

- 9- Bring the transport platform back to base level for unloading. When the transport platform is at the height at which a tie level must be removed, it is important to make sure that the **load inside the transport platform car and on the rear and lateral extensions never exceeds 1500 lb (680 kg)** (workers, tools, mast sections, components for a tie level, material, etc.) to minimize the risk of mast deflection from plumbness and reduce stress on ties and mast assemblies.
- 10- Repeat steps 2 through 9 to remove all mast sections and tie levels, **leaving the last two tie levels in place.**

Removal of tie levels and assembled mast sections

The removal of mast sections and tie levels must be performed by **qualified erectors/dismantlers**. For the definition of a qualified erector/dismantler, refer to p. 7 of the *Performance and Safety Rules* section.

Mast sections can be removed in assembled lengths of mast (also referred to as “sticks”). The use of the optional multiple mast handler is recommended to remove these assembled lengths of mast. The maximum length of assembled mast allowed is equal to the exact number of mast sections to reach the next lower tie level.

It is also important to make sure that the **load inside the transport platform car and on the rear and lateral extensions never exceeds 1500 lb (680 kg)** (workers, tools, mast sections, components for a tie level, material, etc.) during dismantling to minimize the risk of mast deflection from plumbness and reduce stress on ties and mast assemblies.

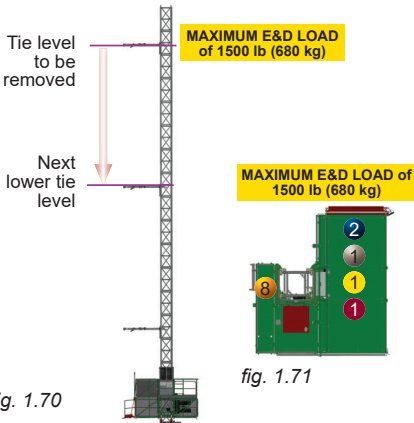

Description	Weight	Load
One-rack mast section	330 lb (150 kg)	0
Components for one tie level	250 lb (113 kg)	250 lb (113 kg)
Scaffold steel plank	30 lb (14 kg)	240 lb (109 kg)
Jib arm	140 lb (64 kg)	0
Worker	265 lb (120 kg)	530 lb (240 kg)
Installation tools	200 lb (91 kg)	200 lb (91 kg)
Total for removal of mast sections and tie level		1220 lb (553 kg)
Maximum weight allowed for other items		280 lb (127 kg)
TOTAL LOAD ON PLATFORM		1500 lb (680 kg)

fig. 1.70

fig. 1.71

fig. 1.72

N

NOTICE

When reaching the height at which to install a tie level and after having installed the mast section, it is important to make sure that the load inside the transport platform car and on the rear and lateral extensions never exceeds 1500 lb (680 kg) (workers, tools, mast sections, components for a tie level, material, etc.) to reduce mast deflection from plumbness and minimize stress on ties and mast assemblies.

Transport Platform with Car System

Dismantling procedure for right-hand side of the unit

Removal of tie levels and assembled mast sections

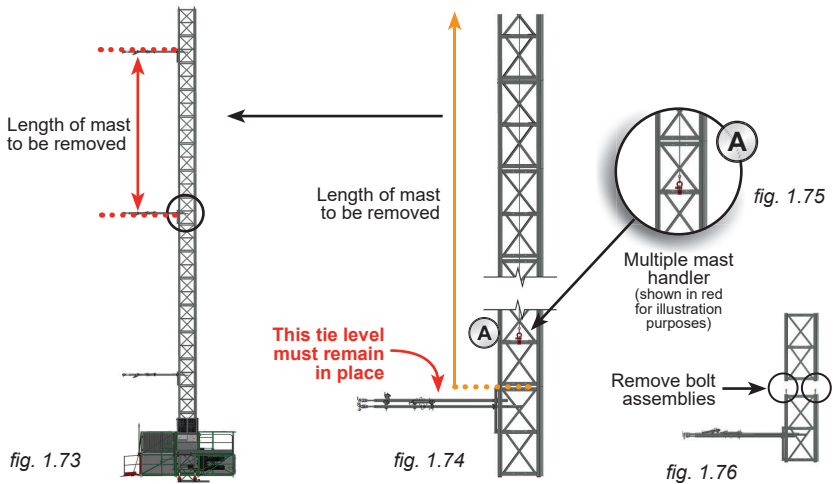

- 1- Prepare the installation as described in the safety guidelines and preparation instructions on p. 26 of this section.
- 2- Bring the motorized unit to where the tie level must be removed.

**CAUTION**

It is **mandatory** to make sure that **all tension (or compression) is released** from the mast tie before attempting to unpin it from the wall tie.

- 3- Make sure that the planks on the mast tie installation deck are into place.
- 4- Remove the tie level. For instructions on how to remove a tie level, refer to p. 73 of the *Mast and Mast Ties* section.
- 5- Make sure to **remove the planks of the mast tie deck**. Make sure that the telescopic plank support tube and the outrigger clear all obstacles. Lower the motorized unit to the next lower tie level (as shown in fig. 1.70, p. 32).

**CAUTION**

Before raising or lowering the motorized unit during dismantling, **make sure that the planks on the mast tie installation deck are not in place** and that the telescopic plank support tube and the outrigger clear all obstacles.

- 6- Install the optional multiple mast handler on the middle step of the lowest mast section of the length of mast to be removed (shown as "A" in fig. 1.74 and fig. 1.75). For instructions on the installation and use of the optional multiple mast handler, refer to p. 86 of the *Accessories* section.
- 7- Using a crane (or a forklift), hold the assembled length of mast to be removed.
- 8- Remove the bolt assemblies joining the lowest mast section of the assembled length to the mast section below (see fig. 1.76, p. 33). Refer to p. 66 of the *Mast and Mast Ties* section for instructions on the removal of mast sections. **Make sure to leave the lower tie level in place.**
- 9- Once the bolt assemblies are removed, carefully lift the length of mast and lower it down in a safe area, away from construction traffic. For instructions on the handling of an assembled length of mast sections, refer to p. 86 of the *Accessories* section.
- 10- Make sure the **load inside the transport platform car and on the rear and lateral extensions does not exceed the maximum E&D load of 1500 lb (680 kg)**. If required, lower the motorized unit to base level to **unload**.
- 11- Repeat steps 2 through 10 to remove all mast sections and tie levels, **leaving the last two tie levels in place.**

Transport Platform with Car System

Removing the main frame of a standard S Series motorized unit

SAFETY comes first. When a standard S Series motorized unit is used for a transport platform with car setup, the main frame must be removed from the motorized unit.

The operations to remove the main frame must be carried out by **qualified erectors/dismantlers or qualified technicians** under the supervision of a **competent person** and be performed with care and precaution. It is mandatory to make sure that the motorized unit installation remains stable and secure throughout the maneuvers to remove the main frame. For the definition of a competent person and the definition of a qualified erector/dismantler or a qualified technician, refer to p. 7 of the *Performance and Safety* section.

Removal of the main frame

- 1- Make sure that the motorized unit is at base level and is not connected to any power source.
- 2- Using the emergency descent system, lower the motorized unit down to the base buffers. For instructions on the use of the emergency descent system, refer to p. 37 of the *Safety Devices* section.
- 3- Make sure the two mast heads are installed on top of the last mast section.
- 4- Using chains or slings, support the main frame assembly, as shown in fig. 1.77 and fig. 1.78.



- 5- Remove both bolts holding the main frame to the rear of the main trolley ("1" in fig. 1.80). Make sure to remove the bolts on **both sides of the main trolley**.
- 6- Remove the bolts at the bottom of the main frame around the bottom mast section ("2" and "3" in fig. 1.80). Make sure to remove the bolts on **both sides of the unit**.
- 7- Remove the top and bottom bolts at the front of the main frame on **both sides of the unit** ("4" in fig. 1.80).
- 8- Loosen (but do not remove) the adjustment bolt ("4" in fig. 1.80).
- 9- Once all bolts are properly removed, remove the main frame **carefully**.

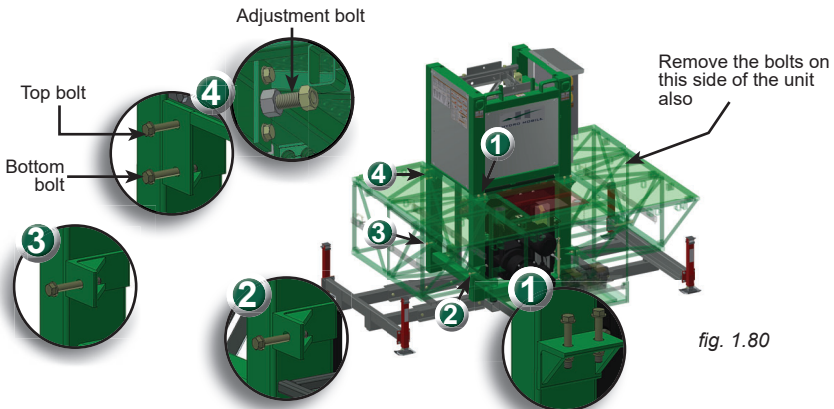

Transport Platform with Car System

Removing the main frame of a standard S Series motorized unit

Removal of the main frame (cont'd)

- 10- Using a crane or a rough terrain forklift, hold the motorized unit by the shackle on the rear mast head (fig. 1.80, p. 34).
- 11- Remove all the leveling jacks and both lateral base extensions.

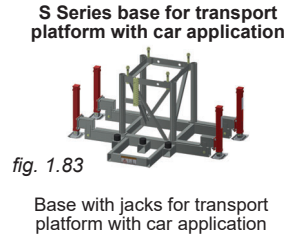
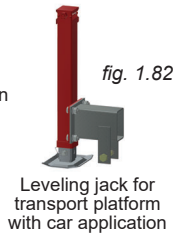
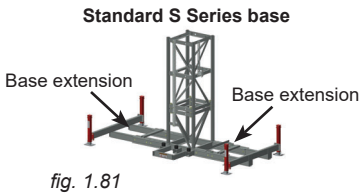

- 12- Install the jacks for transport platform with car applications (fig. 1.82) and secure with 3/4"-10 x 4 1/2" GR8 bolt assemblies. Tighten the bolt assemblies with a torque of 60 lb-ft (81 N-m).
- 13- Once the base is stable, release the motorized unit.

Reinstalling the main frame of a standard S Series motorized unit



SAFETY comes first. When a standard S Series motorized unit has been used for a transport platform car setup, the main frame must be reinstalled on the motorized unit when the setup is dismantled.

The operations to reinstall the main frame must be carried out by **qualified erectors/dismantlers** or **qualified technicians** under the supervision of a **competent person** and be performed with care and precaution. It is mandatory to make sure that the motorized unit installation remains stable and secure throughout the dismantling and reinstallation maneuvers. For the definition of a competent person and a qualified erector/dismantler or a qualified technician, refer to p. 7 of the *Performance and Safety* section.

Reinstallation of the main frame

- 1- Make sure that the motorized unit is at base level and is not connected to any power source.
- 2- Using the emergency descent system, lower the motorized unit down to the base buffers. For instructions on the use of the emergency descent system, refer to p. 37 of the *Safety Devices* section.
- 3- Make sure that all components for the transport platform car application have been removed. Refer to the dismantling procedure on p. 26 of this section for instructions on the dismantling of the transport platform car components.
- 4- Make sure the two mast heads are installed on top of the last mast section.
- 5- Using a crane or a rough terrain forklift, hold the motorized unit by the shackle on the rear mast head (fig. 1.80, p. 34).
- 6- Remove the jacks for transport platform with car applications (fig. 1.82). Store them properly.
- 7- Install both lateral extensions on the base, as shown in fig. 1.81. Tighten all bolt assemblies with a torque of 120 lb-ft (163 N-m).
- 8- Once the base is stable, release the motorized unit.

Transport Platform with Car System

Reinstalling the main frame of a standard S Series motorized unit

Reinstallation of the main frame (cont'd)

- 9- Using chains or slings, support the main frame assembly and bring it in place, around the main trolley of the unit.
- 10- Insert the top bolt assemblies on the front of the main frame on **both sides of the unit** ("1" in fig. 1.84). **Do not tighten the bolt assemblies yet.**

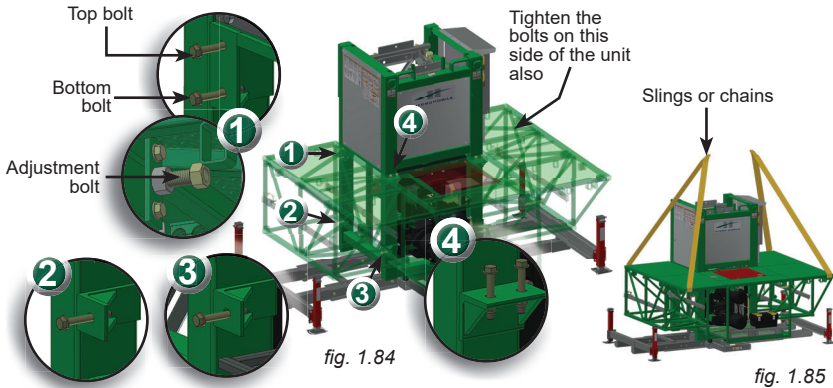

- 11- Insert bolt assemblies at the bottom of the main frame around the bottom mast section ("2" and "3" in fig. 1.84). Make sure to insert bolt assemblies on **both sides of the unit. Do not tighten the bolt assemblies yet.**
- 12- Insert both bolt assemblies holding the main frame to the rear of the main trolley ("4" in fig. 1.84) with a torque of 120 lb-ft (163 N-m). Make sure to tighten the bolts on **both sides of the main trolley.**
- 13- Tighten all bolt assemblies with a torque of 120 lb-ft (163 N-m).
- 14- Once all bolts are properly tightened, release the main frame **carefully.**

Adjustment of the spacing of the main trolley structure

- 15- Raise the motorized unit so it is above the buffers on the base.
- 16- Loosen the two bolts above and under the adjustment bolt inside the main frame (fig. 1.87). Turn the adjustment bolt inside the main frame and set it to apply a pressure sufficient to make sure that the spacing of the structure **measured between the two front tubes at deck level** (fig. 1.85) equals 35 13/16" (91 cm).
- 17- Tighten the bolts with a torque of 120 lb-ft (163 N-m).

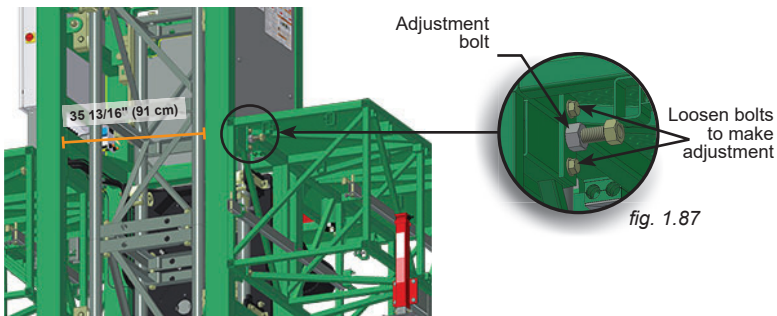

Safety Devices

Emergency Descent Control System

In the event of a power outage, use the gravity-activated emergency descent control system to bring the motorized unit safely down to the **nearest safe evacuation point**. It is important to note that the emergency descent system **must not be used** in the event of damages to a gear box, a brake, a gear or an idler.

Emergency descent procedure

- 1- Turn off the main disconnect switch to shut down the power (fig. 5.1, p. 53). It may be required by local regulations for the operator to be tied to the unit using one of the D-rings on the main frame during the emergency descent (shown in fig. 2.3 and fig. 2.4, p. 38).
- 2- Perform a visual inspection of gears, pinions and rollers and other parts of the structure to make sure that they are clear of debris and that there are no signs of damages that could prevent the emergency descent system from operating normally. The emergency descent system **must not be used if the motorized unit is damaged or suspected to be damaged**. In case of doubt, contact a qualified technician to seek advice. For the definition of a qualified technician, refer to p. 7 of the *Performance and Safety Rules* section.
- 3- Perform a visual inspection of the structure. In case of **doubt** regarding the structural integrity of the installation, the **emergency descent must not be initiated** and the installation must be **evacuated** following the emergency evacuation plan (see step 16 of the general guidelines starting on p. 7 of the *Performance and Safety Rules* section).
- 4- Open the access panel on the rear extension (fig. 2.1). Remove the toggle pin to unlock the emergency descent pedal. Step on and hold the emergency descent pedal fully depressed (fig. 2.2) to initiate the emergency descent. The platform will descend at a pre-determined speed.
- 5- Lower the installation on a distance of 30' (9,1 m) then release the pedal and **let the centrifugal brakes cool down for 5 minutes** before resuming descent. Proceed in that fashion down to the **nearest safe evacuation point**.
- 6- It is important to note that the bottom limit sensor, audible alarm and 10-foot safety stop do not work during a manual descent of the platform. Make sure that all workers on and off the platform have been warned and that the areas below and around the descending setup have been cleared and remain free of obstacles and workers. It is recommended to monitor carefully the lowering of the platform during the emergency descent.

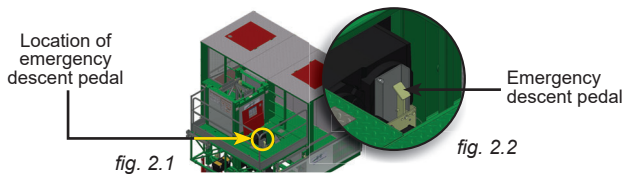

Centrifugal Brakes

The Hydro Mobile S Series is equipped with centrifugal brakes. This safety feature is designed to bring the motorized unit and the installation safely down to the nearest safe evacuation point at a factory-set speed. It is important to make sure that the brakes are **allowed to cool down for 5 minutes after every 30' (9,1 m) of descent**.



WARNING

It is important to make sure that the brakes are allowed to cool down for 5 minutes every 30' (9,1 m) of descent. Failure to allow the brakes to cool down could lead to damages to the equipment, causing serious injury or death.

Safety Devices

Fall Protection

The use of fall protection equipment is **mandatory** for all workers on an S Series transport platform with car setup whenever a fall hazard is present. It is recommended to use a combination of full body harness and a shock-absorbing lanyard. It is mandatory to use certified fall protection equipment that is clean and in good working condition. Fall protection equipment must be inspected before each use and be replaced if found or suspected to be defective.

Refer to the manufacturer's recommendations for more information about the use and care of the selected equipment. Refer also to local regulations for more information about fall protection equipment requirements.

The use of fall protection equipment is **mandatory** when installing and removing tie levels. Using the designated tie points (D-rings) on the main trolley of the motorized unit (fig. 2.3 and fig. 2.4), to secure the fall protection equipment. Tie points are designed to resist to a maximum arrest force of 5000 lb (2268 kg) and can be used by workers to tie themselves to the unit (not more than one worker per tie point).

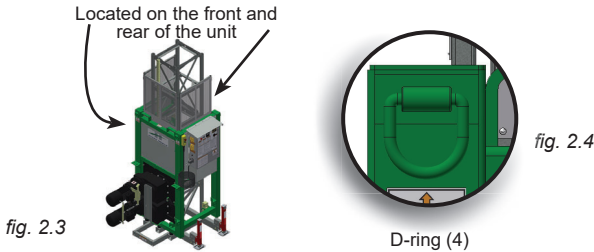

Safety Stop

Safety standards require that transport platform systems be equipped with a detection system that prevents the platform from lowering any further when it is at 10' (3 m) above the bearing surface. This interruption allows the operator to make sure that there are no obstacles underneath the platform and that there is the necessary clearance to bring it down safely to base level. After three seconds, the stop switch will automatically trigger itself off, allowing to resume downward travel.

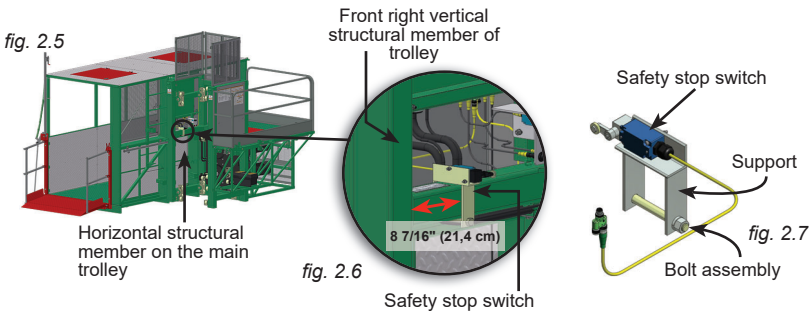

Installation of the safety stop switch

- 1- The installation of the safety stop switch must be performed by a **qualified erector/dismantler**. For the definition of a qualified erector/dismantler, refer to p. 7 of the *Performance and Safety Rules* section. Locate the middle horizontal structural member that is closest to the control panel on the main trolley (fig. 2.5).
- 2- Retrieve the switch assembly from the toolbox.
- 3- Remove the bolt assembly from the support (fig. 2.7)
- 4- Insert the support over the horizontal structural member on the main trolley, at 8 7/16" (21,5 cm) from the inside of the front right vertical structural member, as shown in fig. 2.6, making sure the rocking arm of the switch faces toward the inside of the main trolley.

Safety Devices

Safety Stop

Installation of the safety stop switch (cont'd)

- Secure the support in place with the bolt assembly.

Installation of the trigger on the mast

- Locate the middle horizontal structural member on the third full mast section from base level ("3" in fig. 2.8, p. 39).

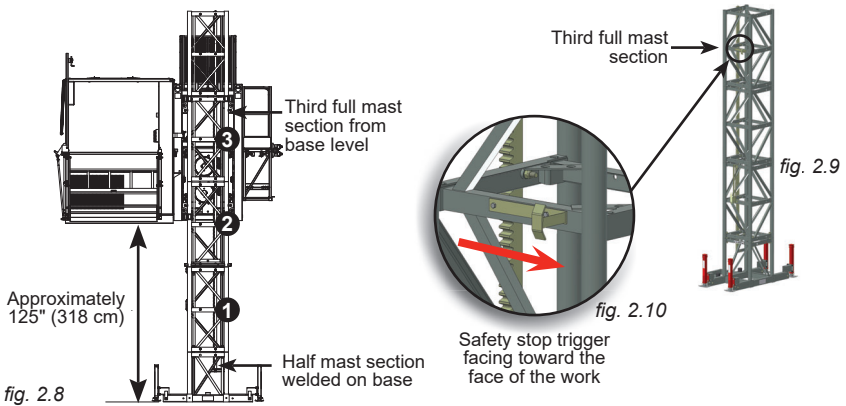

- Bolt the safety stop trigger to the middle horizontal structural member of the third full mast section. Make sure the trigger is facing toward the face of the work.

Connection of the safety stop switch

- Locate the top limit cable under the control panel (TOP LIMIT port, fig. 2.11) and disconnect it. This operation must be performed by a **qualified erector/dismantler** or a **qualified technician**. For the definition of a qualified erector/dismantler or a qualified technician, refer to p. 7 of the *Performance and Safety* section.
- Retrieve the rigid Y connector (parallel) from the toolbox (fig. 2.13) and connect it to the TOP LIMIT port (fig. 2.12).
- Connect the safety stop switch to the rigid Y connector.
- Connect the top limit cable to the rigid Y connector.

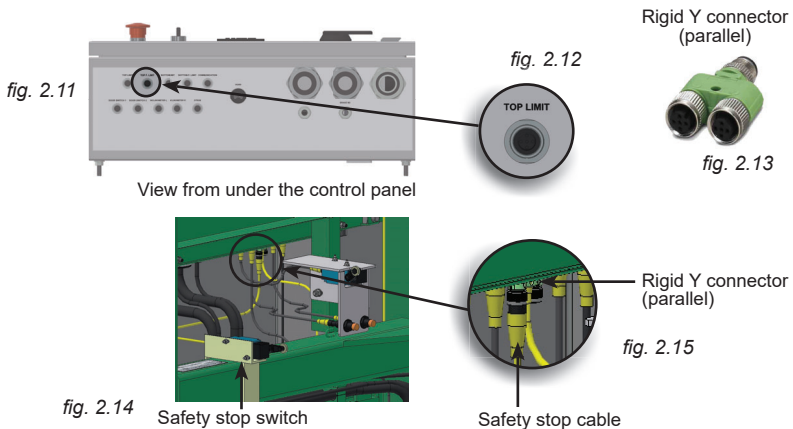

Safety Devices

Gate Detection Switches

The transport platform with car system is equipped with gate detection switches that will prevent operation of the motorized unit if one of the gates (front or rear) is opened and its switch is triggered.

- 1- Locate the DOOR SWITCH 1 and DOOR SWITCH 2 ports under the control panel. This operation must be performed by a **qualified erector/dismantler** or a **qualified technician**. For the definition of a qualified erector/dismantler or a qualified technician, refer to p. 7 of the *Performance and Safety* section.

fig. 2.16

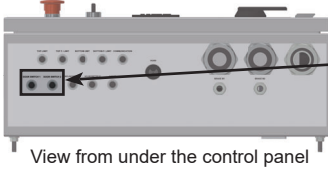

fig. 2.17



fig. 2.18

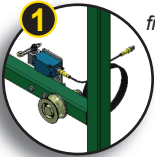

fig. 2.19

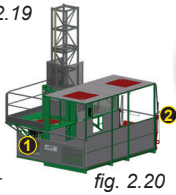

fig. 2.20

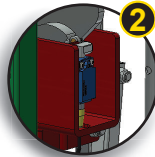

fig. 2.21

Gate detection switch located on the front gate assembly

Rear gate detection switch located on the rear extension

- 2- Connect each gate sensor cable in one of the ports.
- 3- Activate each door switch port on the display screen (fig. 2.18). This operation must be performed by a **qualified erector/dismantler** or a **qualified technician**. For more information about activating functions on the display panel, refer to p. 62 of the *Control Panel* section.

Verification of sensors, switches and screen alerts qualified technician or qualified erector/dismantler only

The adjustment, testing and resetting of the following sensors and switches **must be performed only by a qualified erector/dismantler** or a **qualified technician**. For the definition of a qualified erector/dismantler or qualified technician, refer to p. 7 of the *Performance and Safety* section.

For the testing of sensors and switches to be performed by a **qualified operator**, refer to p. 42 of this section.

Preparation of the motorized unit

- 1- Turn on the main disconnect switch, pull out the emergency stop button and unlock the display screen (fig. 2.22). Make sure that the inclinometer and communication options have been disabled on the screen (fig. 2.18). Refer to the *Power Pack and Operating Components* section on p. 51 for instructions on how to turn on the main power. For information about the functions and alerts of the display screen, refer to p. 56 of the *Control Panel* section.



fig. 2.23

Emergency stop button

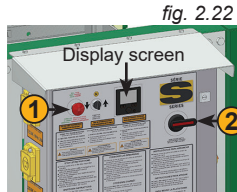

fig. 2.22

Control panel

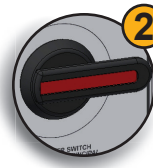

fig. 2.24

Main disconnect switch

Safety Devices

**Verification of sensors, switches and screen alerts
qualified technician or qualified erector/dismantler only**

Preparation of the motorized unit (cont'd)

- 2- Make sure that the control panel does not detect any event that would prevent the safe and proper operation of the unit. It is important to note that when the motorized unit is at base level and resting on the buffers, the screen will display an alert for the bottom final limit (BFL). The unit will not be allowed to travel up or down when a BFL alarm is present.

Adjusting the bottom limit and bottom final limit trigger

- 3- Make sure to install at least one mast section other than the one supplied with the unit (fig. 2.29). Refer to p. 65 of the *Mast and Mast Ties* section for instructions on the installation of mast sections.
- 4- Loosen the bolt and raise the bottom limit/bottom final limit (BL/BFL) trigger (see fig. 2.25 and fig. 2.26) by about 12" (30,5 cm). Tighten the bolt to secure the trigger in place.
- 5- Perform a position reset on the display screen (fig. 2.30) to allow the motorized unit to travel upwards. For instructions on how to perform a position reset, refer to p. 63 of the *Control Panel* section.
- 6- Raise the motorized unit until it reaches the BL/BFL trigger. The motorized unit will stop and the screen will display an alert for the bottom final limit (BFL).
- 7- Loosen the bolt and lower the BL/BFL trigger and set its position so the bottom limit sensor **stops the motorized unit at least 7" (18 cm) above the top of the buffers on the base** (fig. 2.28). Tighten the bolt to secure the trigger in place.
- 8- Perform a position reset on the display screen (fig. 2.30) to allow the motorized unit to travel downwards.

Testing the bottom final limit switch

- 9- Locate the bottom final limit switch (fig. 2.32). To test the switch, lift the arm. If the switch is working properly, the screen will display an alert for the bottom final limit (BFL) and the unit will not be allowed to travel downwards. Release the arm of the switch.

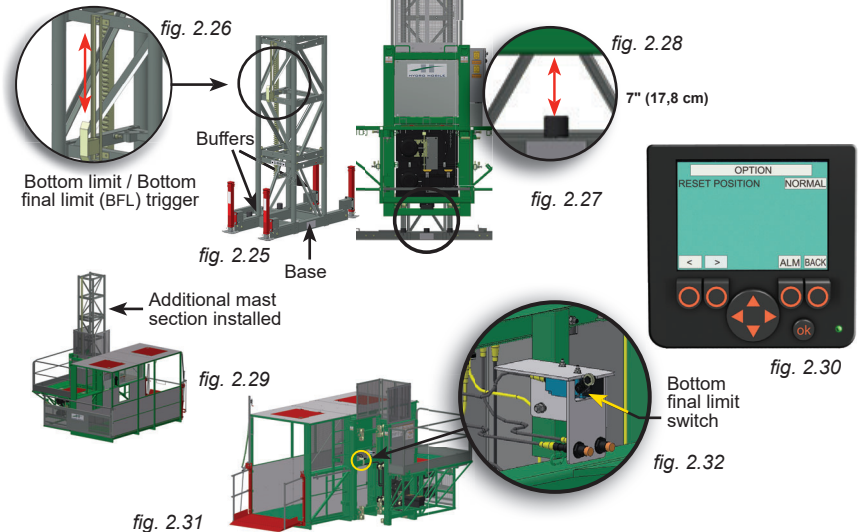

N	NOTICE
<p>On standard S Series motorized units bearing serial numbers S-0068 and up or S Series units manufactured specifically to be used in transport platform car applications, triggering the bottom final limit (BFL) or the top final limit (TFL) will cause a fault of the bottom (or top) final limit circuit: this will lock the motorized unit and prevent operation. In such a case, only a qualified erector dismantler or a qualified technician can unlock the motorized unit.</p>	

Safety Devices

Verification of sensors, switches and screen alerts
qualified technician or qualified erector/dismantler only

Testing the bottom final limit switch (cont'd)

- 10- Perform a position reset on the display screen (fig. 2.30, p. 41) to allow the motorized unit to travel downwards. For instructions on how to perform a position reset, refer to p. 63 of the *Control Panel* section.

Testing the top final limit switch

- 11- With the motorized unit at base level (above the BL/BFL trigger), test the top final limit switch by carefully raising the unit, using extreme care, until it is above the first mast section. If the switch is working properly, the screen will display an alert and prevent upward travel.
- 12- Lower the motorized unit to base level until the BL alarm is displayed on the screen. The screen will then also display a "TOP FINAL LIMIT" (top final limit fault) alert, preventing the motorized unit to travel upwards.
- 13- Perform a position reset on the screen to allow the motorized unit to travel upwards.
- 14- If any of the switches or sensors is not working properly, the unit must be put out of service until it has been inspected and repaired by a qualified person. For the definition of a qualified person, refer to p. 7 of the *Performance and Safety Rules* section. For more information about switches and their corresponding alerts, refer p. 56 of the *Control Panel* section.

Verification of sensors, switches and screen alerts
qualified operator

The adjustment, testing and resetting of the following sensors and switches **can be performed by a qualified operator**. For the definition of a qualified operator, refer to p. 7 of the *Performance and Safety* section.

For the testing of sensors and switches to be performed by a **qualified erector/dismantler** or a **qualified technician**, refer to p. 40 of this section.

Preparation of the motorized unit

- 1- Turn on the main disconnect switch, pull out the emergency stop button and unlock the display screen (fig. 2.33). Make sure that the inclinometer and communication options have been disabled on the screen (fig. 2.36). Refer to the *Power Pack and Operating Components* section on p. 51 for instructions on how to turn on the main power. For information about the functions and alerts of the display screen, refer to p. 56 of the *Control Panel* section.



Emergency stop button

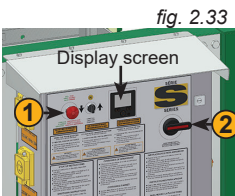

Control panel



Main disconnect switch



fig. 2.36

fig. 2.34

fig. 2.35

- 2- Make sure that the control panel does not detect any event that would prevent the safe and proper operation of the unit. It is important to note that when the motorized unit is at base level and resting on the buffers, the screen will display an alert for the bottom final limit (BFL). The unit will not be allowed to travel up or down when a BFL alarm is present.

Safety Devices

Verification of sensors, switches and screen alerts qualified operator

Testing the bottom limit sensor

- 3- To test the bottom limit sensor, raise the motorized unit by about 12" (30 cm) then lower it again. If the switch is working properly, the motorized unit will stop and no longer be able to go down, the panel will display an alert, and the distance measured between the bottom tube of the main frame and the top of the buffers on the base will be **at least 7" (18 cm)**. Adjust the detection distance or replace the bottom limit sensor, if necessary. The adjustment or the replacement of the bottom limit sensor must **only** be performed by a **qualified erector/dismantler** or a **qualified technician**.

Testing the top limit sensor

- 4- Remove the aluminum cover located under the control panel.
- 5- Test the top limit switch by placing a metal object in front of it. If the switch is working properly, the screen will display an alert and prevent upward travel. Adjust the detection distance or replace the top limit switch, if necessary. The adjustment or the replacement of the top limit switch must **only** be performed by a **qualified erector/dismantler** or **qualified technician**.

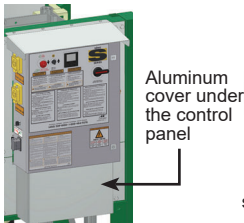
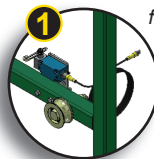

fig. 2.37



Rear gate detection switch located on the rear extension

fig. 2.38

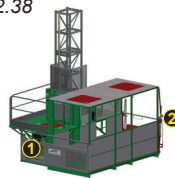
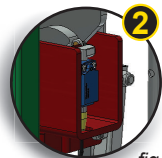

fig. 2.39



Gate detection switch located on the front gate assembly

fig. 2.40

Testing the gate sensors

- 6- Replace the aluminum cover.
- 7- Make sure all gates are closed properly.
- 8- With the motorized unit slightly above the bottom limit sensor, open the front gate. If the gate sensor is working properly, the panel will display an alert and prevent any travel (up or down). If the bottom limit sensor is not working properly, call a **qualified erector/dismantler** or a **qualified technician**.
- 9- Repeat step 8 for the rear gate sensor.

Testing the safety stop

- 10- With the motorized unit at base level, raise the motorized unit and make sure it does not stop until it is 12' (3,7 m) above base level.
- 11- Lower the motorized unit and make sure it stops for three seconds when it is 10' (3 m) above base level.

Safety Devices

Verification of sensors, switches and screen alerts qualified operator

Testing the emergency stop button on the control panel

- 12- With the motorized unit at base level, raise the motorized unit.
- 13- While the motorized unit is rising, press the emergency stop button on the control panel. If the button is working properly, the motorized unit will stop immediately.
- 14- With the motorized unit on the first full mast section, lower the motorized unit.
- 15- While the motorized unit is lowering, press the emergency stop button on the control panel. If the button is working properly, the motorized unit will stop immediately.

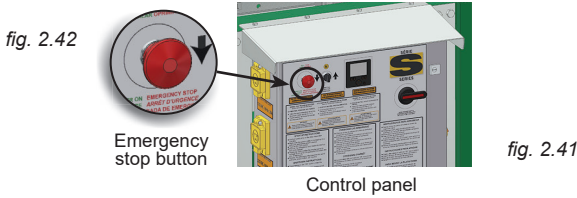

Testing the emergency stop button on the control pendant

- 16- Make sure the control pendant is clean, in an appropriate condition and connected properly. For instructions on the connection and use of the control pendant, refer to p. 64 of the *Control Panel* section.
- 17- Make sure the control pendant switch is enabled (turned to the right side, fig. 2.45).
- 18- With the motorized unit at base level, raise the motorized unit.
- 19- While the motorized unit is rising, press the emergency stop button on the control pendant. If the button is working properly, the motorized unit will stop immediately. Check the connection of the pendant or replace the pendant, if necessary.
- 20- With the motorized unit on the first full mast section, lower the motorized unit.
- 21- While the motorized unit is lowering, press the emergency stop button on the control pendant. If the button is working properly, the motorized unit will stop immediately. Check the connection of the pendant or replace the pendant, if necessary.

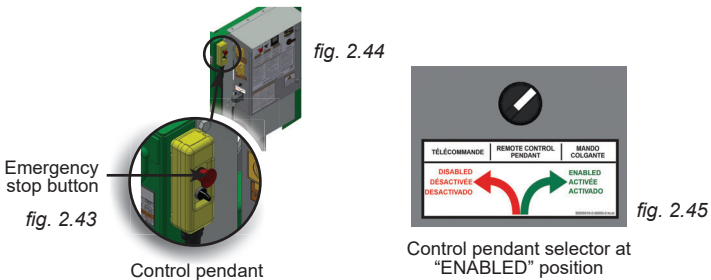

- 22- If any of the switches or sensors is not working properly, the unit must be put out of service until it has been inspected and repaired by a qualified technician. For the definition of a qualified technician, refer to p. 7 of the *Performance and Safety Rules* section. For more information about switches and sensors, and their corresponding alerts, refer to p. 56 of the *Control Panel* section.

Transport Platform Car and Extensions

The transport platform car for the S Series is installed directly on the main trolley of the motorized unit. Since there is no main frame on the S Series motorized unit for transport platform with car application or since the main frame has been removed if a standard unit is used, extensions (rear and lateral) are required to be installed to offer safe access to unit components such as the emergency descent control system. These extensions are required to ensure the integrity of the structure.

The S Series transport platform car is configured in factory to be installed on the **right side** of a motorized unit. For a **left side** installation, contact the Hydro Mobile technical team for installation instructions.



fig. 3.1

1 Installation of the rear extension

- 1- Make sure that the motorized unit has been installed properly and that there are **two tie levels in place**.
- 2- Raise the motorized unit until it is 1' (0,3 m) above the base buffers.
- 3- Make sure the two leveling jacks on the right side of the unit have been removed (fig. 3.2).

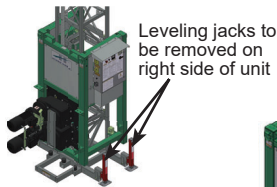

fig. 3.2

Rear extension

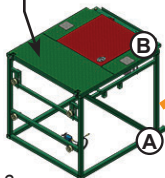

fig. 3.3

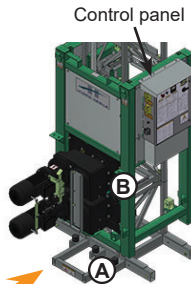

fig. 3.5

Tube on bottom of rear extension



fig. 3.4

fig. 3.6

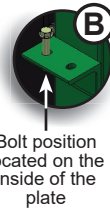

Bolt position located on the inside of the plate

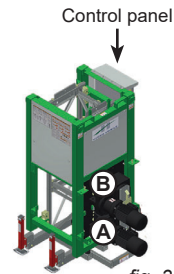

fig. 3.7

Control panel

Tube on bottom of extension must rest against bottom of vertical tubes on main trolley



fig. 3.8

- 4- Using a lifting device such as a crane or a rough terrain forklift, carefully lift and align the rear extension with the back of the motorized unit (fig. 3.3). The bottom tubes ("A" in fig. 3.3) must be snug against the vertical tubes of the main trolley.
- 5- Secure the rear extension to the main trolley ("B" in fig. 3.3 and in fig. 3.5) using 5/8" x 4" (GR8) bolt assemblies in the **inside** position ("B" in fig. 3.6) of each plate on the main trolley (fig. 3.5). Bolt assemblies must not be tightened yet



WARNING

It is **critical** to make sure that all components installed (lateral and rear extensions, transport platform car) remain in place **at all times** until the setup is dismantled. A transport platform with car installation that does not have all its components in place must not be used until it has been inspected and repaired by a qualified person.

Transport Platform Car and Extensions

2 Installation of the lateral extension

6- Lift and align the lateral extension with the left side of the main trolley of the motorized unit (fig. 3.9).

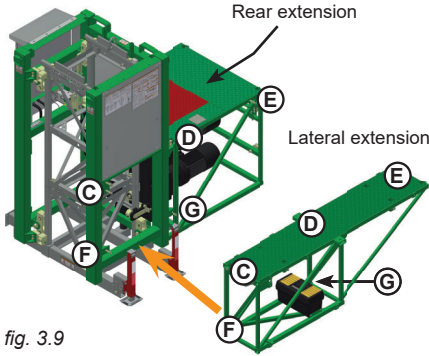

fig. 3.9

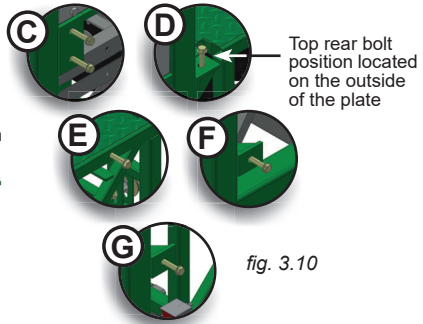

fig. 3.10

7- Secure the lateral extension to the main trolley of the motorized unit, using bolt assemblies in the locations shown above ("C", "D", "E", "F" and "G"). Bolt assemblies must not be tightened yet.

Bolt size of assemblies

C	5/8"-11 x 4 1/2" (GR8)	F	5/8"-11 x 4 1/2" (GR8)
D	5/8"-11 x 4" (GR8)	G	5/8"-11 x 4 1/2" (GR8)
E	5/8"-11 x 5 1/2" (GR8)		

3 Installation of the transport platform car

8- Using a crane, a rough terrain forklift or any other appropriate lifting device, carefully lift and align the transport platform car with the **right side** of the motorized unit (fig. 3.11). If using a forklift, make sure to use an appropriate forklift attachment to secure the sling (shown in red in fig. 3.11).

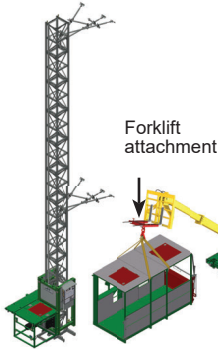

fig. 3.11

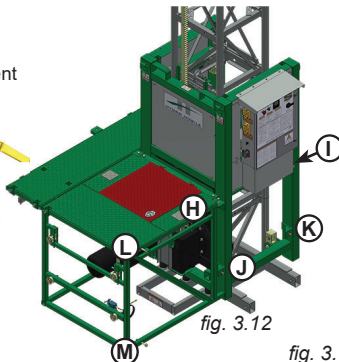

fig. 3.12

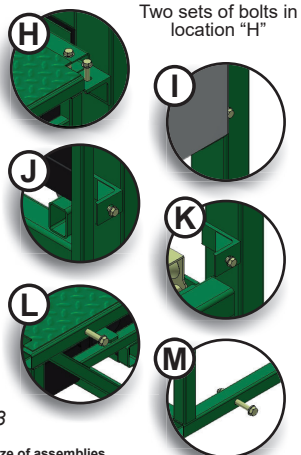

fig. 3.13

9- Bolt the transport platform car to the main trolley of motorized unit using four bolt assemblies (shown as "H", "I", "J" and "K" in fig. 3.12) and to the rear extension using two bolt assemblies (shown as "L" and "M" in fig. 3.12).

Bolt size of assemblies

H	5/8"-11 x 4" (GR8)	K	5/8"-11 x 2 1/4" (GR8)
I	5/8"-11 x 4" (GR8)	L	5/8"-11 x 5 1/2" (GR8)
			5/8"-11 x 2 1/4" (GR8)
		M	5/8"-11 x 5 1/2" (GR8)
			[BOTTOM]
J	5/8"-11 x 2 1/4" (GR8)		

10- Tighten all bolt assemblies on the extensions (rear and lateral) and the car with a torque of 120 lb-ft (163 N-m).

Transport Platform Car and Extensions

Adjustment of the spacing of the main trolley structure

- 11- Make sure that the motorized unit is above the buffers on the base.
- 12- Loosen the two bolts above and under the adjustment bolt inside the frame of the lateral extension (fig. 3.15). Turn the adjustment bolt (fig. 3.15) and set it to apply a pressure sufficient to make sure that the spacing of the structure **measured between the top of the two tubes on the front of the main trolley** (fig. 3.14) equals 36 1/16" (91,5 cm).
- 13- Tighten the bolts loosened in step 12 with a torque of 120 lb-ft (163 N-m).

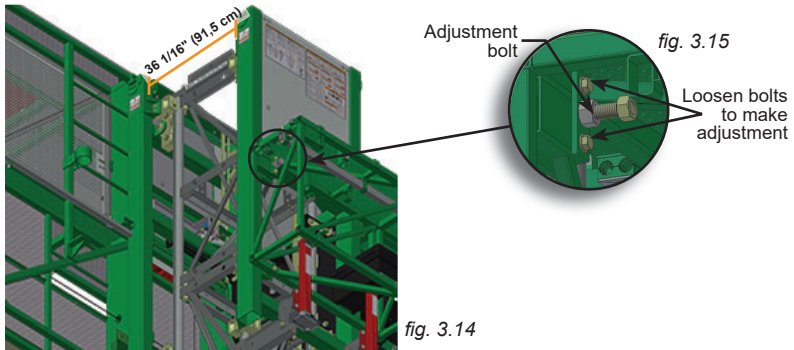

NOTICE

In order to avoid damages to the equipment, it is important to set the adjustment bolt properly to apply a pressure sufficient to maintain an adequate spacing of the structure on the front of the motor trolley unit.

Installation of the rear (sliding) platform gate

- 14- Loosen and remove the bolt assemblies securing the two top guide rollers to the adjustment bracket (fig. 3.16 and fig. 3.17). Put the wheels aside. Do not tamper with the adjustment of the bracket.
- 15- Retrieve the rear (sliding) platform gate and insert it on the rear extension, making sure the bottom midrail of the sliding gate is engaged on the bottom guide wheels (fig. 3.16).
- 16- Reinstall the two top guide rollers on the adjustment bracket using their bolt assemblies. Tighten the bolts with a torque of 30 lb-ft (41 N-m).
- 17- Close and secure the rear (sliding) platform gate with the top spring lock bolt (fig. 3.19 and fig. 3.20).

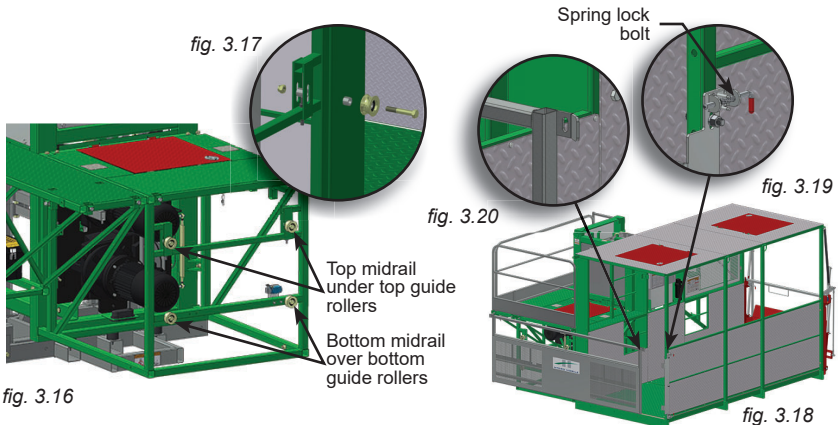

Transport Platform Car and Extensions

Installation of the extension guardrails

18- Insert the legs of a guardrail in the pockets located on the decks of the rear and lateral extensions (fig. 3.21, fig. 3.23 and fig. 3.26). Tighten the bolts with a torque of 30 lb-ft (41 N-m) to secure each guardrail in place.

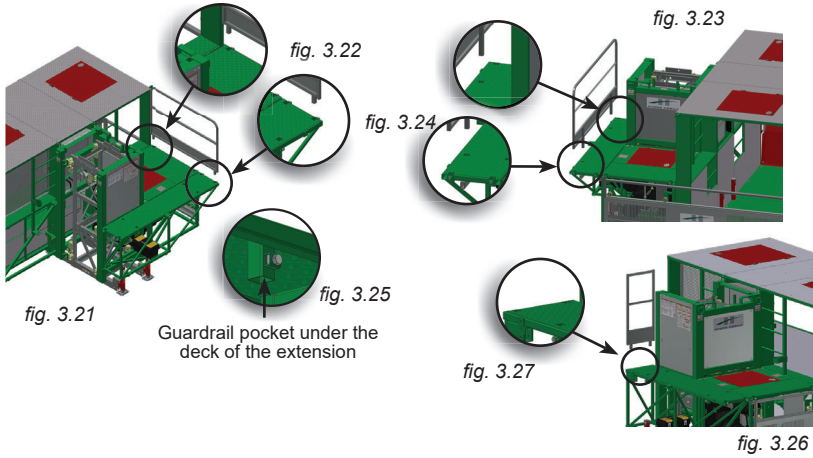

Installation of the mast tie installation deck

19- Install the outrigger support assembly on the lateral extension using one 5/8"-8 x 8" (GR8) bolt assembly in the **front** position and one 5/8"-8 x 7" (GR8) bolt assembly in the **rear** position. Tighten both bolt assemblies with a torque of 120 lb-ft (163 N-m).

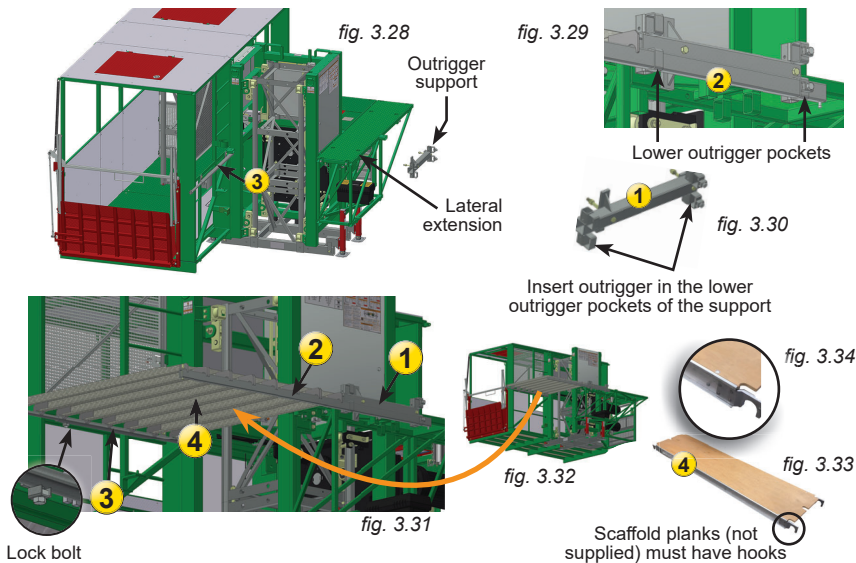

20- Retrieve the 100" (254 cm) outrigger stored inside the lateral extension ("2" in fig. 3.31).

Transport Platform Car and Extensions

Installation of the mast tie installation deck (cont'd)

- 21- Loosen the bolts on the lower pockets of the outrigger support and insert the 100" (254 cm) outrigger. Make sure the outrigger is pulled all the way out towards the front. **Do not tighten the pocket bolts yet.**
- 22- Pull out the telescopic plank support tube ("3" in fig. 3.31, p. 48) until it has the same length as the outrigger installed in the previous step or 15" (38,5 cm) between the fixed part of the tube and the extremity of the telescopic portion of the tube. **The lock bolt must not be tightened yet.**
- 23- Install mast tie installation planks (not supplied) ("4" in fig. 3.31, p. 48) over the telescopic plank support tube and the outrigger. It is required to use 6' (1,8 m) steel scaffold planks (total of seven) with hooks, as shown in fig. 3.33, p. 48.
- 24- Push in the telescopic tube and the outrigger until the planks are snug against the main trolley and the lateral extension. Put the plank stop pin on the outrigger and tighten all bolts with a torque of 30 lb-ft (41 N-m) to secure everything in place.
- 25- **Before raising or lowering the motorized unit, make sure that the planks are removed and that the telescopic plank support tube and the outrigger clear all obstacles.**

Removal of the mast tie installation deck

- 1- Loosen the lock bolt on the telescopic plank support tube (fig. 3.31, p. 48) and the outrigger pocket bolts (fig. 3.29, p. 48).
- 2- Remove the mast tie installation planks ("4" in fig. 3.31, p. 48) and store them properly.
- 3- Push in the telescopic tube ("3" in fig. 3.31, p. 48) and secure in place.
- 4- Push in the outrigger ("2" in fig. 3.31, p. 48) and secure in place by tightening the pocket bolt.

Loading the transport platform car

- 1- Make sure the transport platform has been installed properly and passed for use, as described in the installation guidelines and instructions beginning on p. 15 of the *Transport Platform System* section.
- 2- At the start of the day or before every working shift, make sure that every step in the daily inspection checklist has been performed. Refer to p. 91 of the *Transport, Storage and Maintenance* section for more information about the daily inspection checklist.
- 3- Slide open the rear platform gate. Load material in the transport platform car, making sure not to overload the car and that the floor of the transport platform car has the proper bearing capacity. No load must be applied on a guardrail or a gate, nor on the top of the transport platform car. Materials must be stored away from guardrails and gates. It is also forbidden for anyone to lean on a guardrail or a gate. Refer to the *Load Capacities* section on p. 76 for more information about loading the transport platform car.
- 4- Once loading is complete, close the rear (sliding) platform gate and lock it properly.

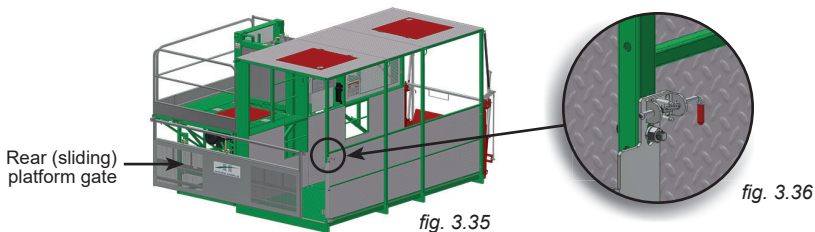

NOTICE

No load must be applied on a guardrail or a gate, nor on the top of the transport platform car.

Unloading the transport platform car

- 1- Make sure that landing level safety gates have been installed at all floors that will be accessed. For best results, it is suggested to make sure that each landing level is identified by markings on the mast or on the building to be clearly visible by the operator.

Transport Platform Car and Extensions

Unloading the transport platform car (cont'd)

- 2- Bring the motorized unit to the appropriate landing level.
- 3- Make sure that the unit has come to a full stop and is positioned properly to ensure that the landing ramp can be seated correctly on the landing point, as shown in fig. 3.39. The floor of the transport platform car must be between 5 1/2" and 7" (14 cm and 18 cm) above the landing point.

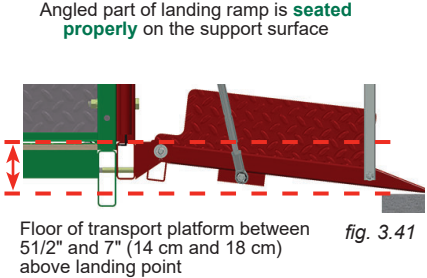
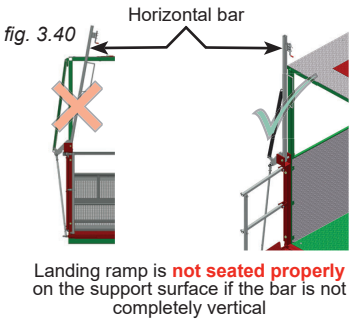
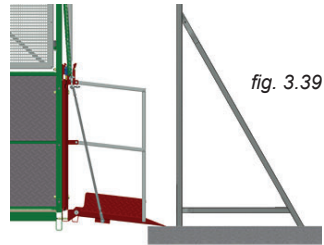
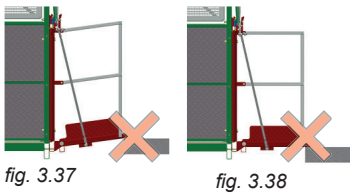

- 4- Release the spring bolt (fig. 3.43) on the front gate and raise the horizontal bar (fig. 3.42) to unfold the landing ramp and the lateral guardrails.
- 5- Make sure that the horizontal bar is completely raised and vertical so that the landing ramp can sit properly on the floor slab or the support structure.
- 6- Once unloading is complete, lower the bar using the handle (shown in fig. 3.45) to close the front platform gate assembly. Secure the gate assembly with the spring lock bolt.

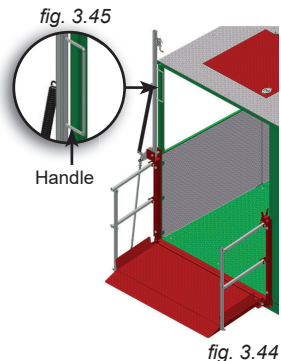
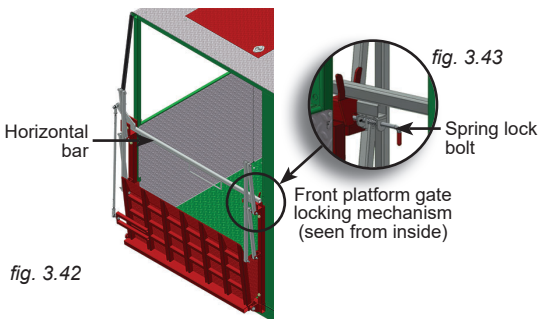

Power Pack and Operating Components

General Guidelines

- 1- Select a power cable that is suitable for the height of the installation. **The installation of the power cable must be performed by a certified electrician.** Refer to the *Power Cable Selection* chart (fig. 4.1) to select the appropriate power cable for the installation. Make sure that the overall length of the cable is sufficient for the installation (height of mast, distance from power source, acceptable overall slack in cable). Contact the Hydro Mobile technical team if a cable longer than 800' (244 m) is required.
- 2- Install the power cable as described in the installation instructions hereafter.

fig. 4.1

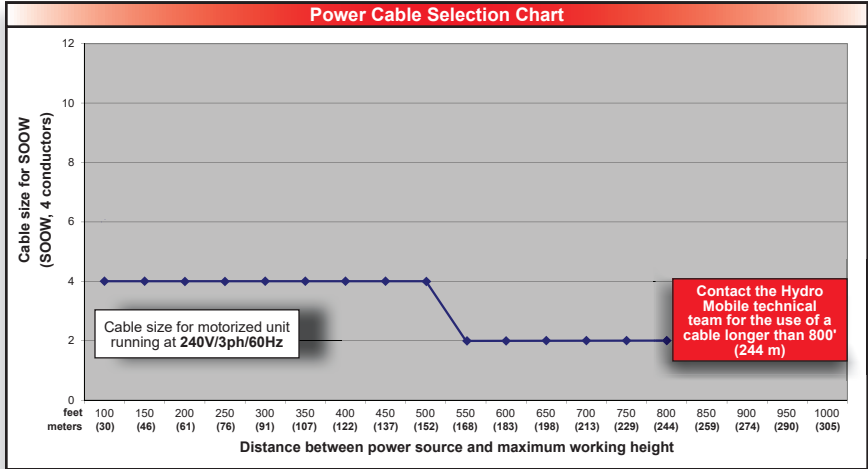

Installation of the Power Cable

Installation **without** an optional cable trolley

- 1- Retrieve the open mesh grip kit from the toolbox. Using a U-bolt and flat bar assembly, attach an open mesh grip (fig. 4.2) at the bottom of the horizontal truss on the outside of the car. Run the cable through the wire mesh grip. Make sure to use a cable grip appropriate for the size of the cable.
- 2- Make sure the cable clears the base completely.
- 3- Connect the power cable to the control panel and to a safe and reliable power source (from the building or a generator). **This installation must be performed by a certified electrician.** Make sure that the input voltage is within the specified range. Refer to p. 11 of the *Transport Platform System* section for more information on the input power range.
- 4- Proceed with the motorized unit startup procedure, on p. 52.



fig. 4.2



WARNING

Installation of the power cable must be performed by a certified electrician.

Power Pack and Operating Components

Installation of the Power Cable

Installation with an optional cable trolley

The S Series transport platform system must not be used on mast with a height over 500' (152 m). To maximize efficiency and because of the speed of travel, it is recommended to use the S Series transport platform with car system on a mast with a height of 200' (61 m) or less.

On a mast with a height over 150' (45,7 m), the use of the **optional cable trolley kit** is recommended. However, it must be noted that when the optional cable trolley is installed, the **transport platform car can no longer lower all the way down to base level**, as clearance is required under the unit for the cable trolley installation, as shown in fig. 1.16, p. 13.

- 1- Install the optional cable trolley kit as described in the installation instructions on p. 81 of the *Accessories* section.
- 2- Connect the power cable to the control panel and to a safe and reliable power source (from the building or a generator). **This installation must be performed by a certified electrician.** Make sure that the input voltage is within the specified range. Refer to p. 11 of the *Transport Platform System* section for more information on the input power range.
- 3- Proceed with the motorized unit startup procedure hereafter.

Motorized unit startup procedure

- 1- Prepare the motorized unit by following the general guidelines, on p. 51.
- 2- Turn on the main disconnect switch (fig. 5.1, p. 53).
- 3- Pull out the emergency stop button (fig. 5.1, p. 53) to power on the display screen. If the display screen does not turn on after a short period of time, make sure that the power cable is properly connected to both the power source and to the motorized unit. If the cable is connected, verify the phase selector and make sure the appropriate phase has been selected.
The phase selector must be at the top (1) or bottom (2) position.
The middle (0) position is neutral and will prevent the unit and control panel from powering on. If the display screen still does not turn on, push in the emergency stop button, turn off the main disconnect switch and contact a certified electrician or a qualified technician. For the definition of a qualified technician, refer to p. 7 of the *Performance and Safety* section.
- 4- Once powered on, unlock the display screen as described in the instructions on p. 54 of the *Control Panel* section.

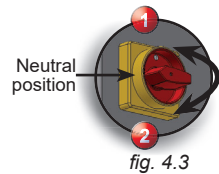

Preventing unauthorized use of the motorized unit

To prevent unauthorized use of the motorized unit, refer to p. 63 of the *Control Panel* section for instructions.

Motorized unit shutdown procedure

- 1- Bring the motorized unit down until the bottom limit is triggered. The screen will display an alarm.
- 2- Push in the emergency stop button to shut down the control panel.
- 3- Turn off the main disconnect switch.
- 4- Before transporting or storing the unit for any significant length of time, refer to instructions on p. 90 of the *Transport, Storage and Maintenance* section.



Auxiliary power outlets are disabled when the motorized unit is moving.

Control Panel

The control panel is the brain behind the Hydro Mobile S Series system. The control panel is a combination of manual controls and a color non touch screen. Driven by a computer system programmed to detect and analyze every signal and react accordingly, the display screen will notify the operator of any important event and display appropriate instructions to respond to the alert (see figures below as well as descriptions and instructions included in the *Screen Alerts and Instructions* in the following pages). Instructions and descriptions on the control panel are displayed in three operating languages (English, French and Spanish). Screen displays and instructions are in English, French and Spanish.

It is mandatory to comply with the instructions included in the following pages for the operation of the control panel and to take prompt corrective action when required. For any event other than those described in this manual, contact the distributor/service center or the Hydro Mobile technical team.

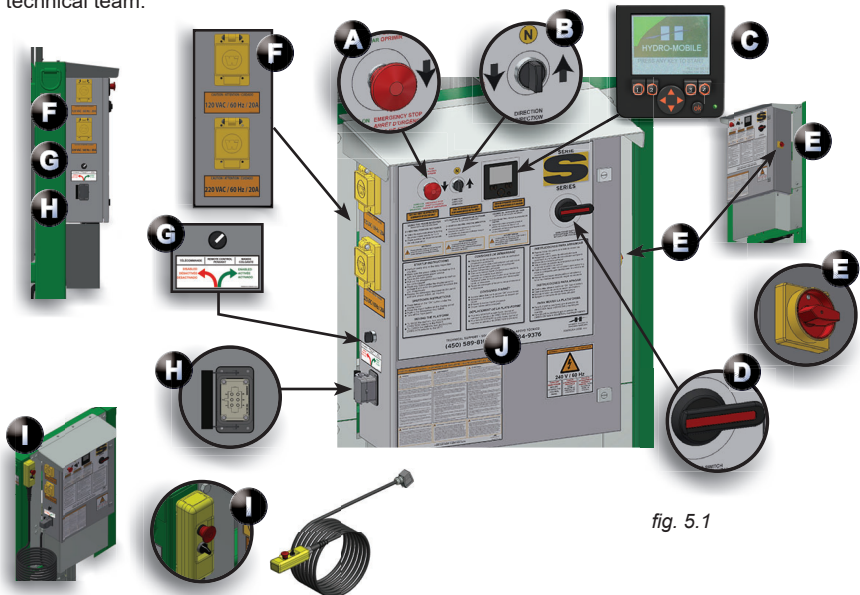

fig. 5.1

Control panel components			
A	Emergency stop button	F	Power outlets (120 and 220 VAC)
B	Rise and descent selector	G	Control pendant selector switch
C	Display screen	H	Control pendant connection port
D	Main disconnect switch	I	Control pendant
E	Phase selector	J	Operation and safety instructions

fig. 5.2



If the display screen does not turn on after a short period of time, make sure that the power cable is properly connected both to the power source and to the motorized unit and that the appropriate phase sequence has been selected. If the display screen still does not turn on, turn off the main disconnect switch and contact a certified electrician or a qualified technician.

Control Panel

fig. 5.3

Control panel controls		
Control	Description	Action
Rise and descent selector	Controls the travel direction of the unit.	Turn and hold the selector to the right to raise the platform. Turn and hold the selector to the left to lower the platform.
Emergency stop button	Shuts down the power to the control panel in the course of normal operation or in case of an emergency.	In the course of normal operation , push in the emergency stop button to shut down the power to the control panel when the unit is not in use. In case of emergency , push in the emergency stop button to shut down the power to the control panel.
Main disconnect switch	Turns the main power on or off.	Turn the handle down to power on (clockwise). Turn the handle up to power off (counterclockwise).
Phase selector	Selection of the phase.	Turn the selector to the top (1) or bottom (2) position. Middle (0) position is neutral; the unit and panel cannot be powered on.
Control screen	Non touch screen (with options and navigation buttons) displaying alerts and instructions.	Refer to information included in the following pages to appropriately understand each of the messages displayed on the screen.



fig. 5.4

Screen alerts and instructions

Unlocking the display screen

- 1- Turn on the main disconnect switch. Pull out the emergency stop button.
- 2- If the display screen does not turn on after a short period of time, make sure that the power cable is properly connected to both the power source and to the motorized unit. If the cable is connected, verify the phase selector and make sure the appropriate phase has been selected. The phase selector ("E" in fig. 5.1, p. 53) must be at the top (1) or bottom (2) position (see fig. 4.3, p. 52). The middle (0) position is neutral and will prevent the unit and control panel from powering on. If the display screen still does not turn on, turn off the main disconnect switch and contact a certified electrician or a qualified technician. For the definition of a qualified technician, refer to p. 7 of the *Performance and Safety* section.
- 3- Once the panel is powered on, press on any key under the display screen to activate it.
- 4- Once on the access code entry page, it is possible to change the display language by pressing the rightmost button (button 4 on fig. 5.5, p. 55).
- 5- If an event is detected by the control panel, the ALM rectangle will blink (above button 3 in fig. 5.5, p. 55) to indicate it. The display screen must be unlocked to display the alert info screen.
- 6- To enter the operating access code (default "10"), press on the OK button. Once the input box is blinking, use the UP and DOWN arrows (on the navigation button) to change the value, then press OK to unlock the display screen. The default operating access code can be changed by a qualified erector/dismantler or a qualified technician. For the definition of a qualified erector/dismantler or a qualified technician, refer to p. 7 of the *Performance and Safety Rules* section.

Control Panel

Screen alerts and instructions

Unlocking the display screen (cont'd)

7- Once unlocked, the screen displays the main menu page. Press on the appropriate option button to go to the selected option.

Locking the display screen

To lock the display screen and prevent unauthorized operation, refer to p. 63 of this section.

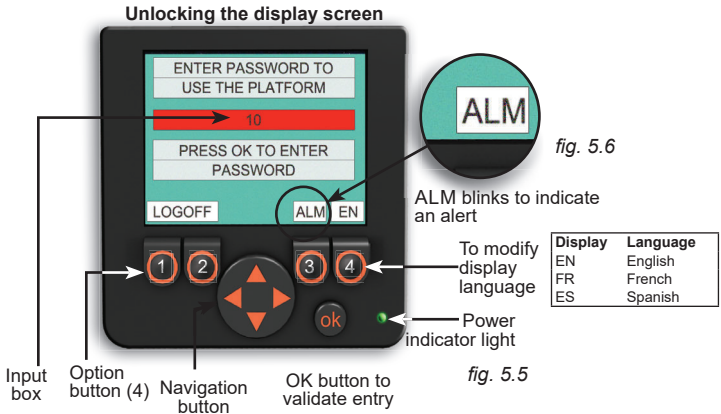

Note: Numbers on the option buttons in the images on the following pages are displayed as an example only. Actual messages displayed may differ from picture.

Main menu screen



fig. 5.7

fig. 5.8

Screen	Description	Access level
F1 – Status info	Information on the status of the unit and its components (door sensors, total runtime hours, etc.)	Operator
F2 – Alarms	Information on any event detected by the control panel that could prevent the unit and its components to operate safely	Operator
F3 – Inputs and outputs	Status of various controls, sensors and switches linked to input and output ports	Operator
F4 – Configuration	Screens allowing the modification of certain options for the unit or the installation (enabling door sensors, modifying user-level password, resetting maintenance runtime counter, etc.)	Erector/ Dismantler (level 1)
Pressing twice on OK button	Entry-level access page to log out and lock panel	Operator

F1 – Status info

Access level: User / Operator

This two-page section displays general information about the unit and the installation.

- 1- Press F1 on the main menu screen (button 1 on the main menu screen display example in fig. 5.7).
- 2- Change display pages with the option buttons (buttons 1 and 2 in fig. 5.9, p. 56).
- 3- Press the BACK button (button 4 in fig. 5.9, p. 56) to return to the main menu page.

Control Panel

Screen alerts and instructions

F1 – Status info

Access level: User / Operator

fig. 5.9



Screen 1 of Status Info

fig. 5.10



Screen 2 of Status Info



Note: Numbers on the above option buttons are displayed as an example only. Actual messages displayed may differ from picture.

F2 – Alerts

Access level: User / Operator



fig. 5.12

Note: Numbers on the above option buttons are displayed as an example only. Actual messages displayed may differ from picture.

This section displays events detected by the control panel that could compromise the safe operation of the unit and its components. Display of the various alerts will alternate automatically if more than one page is required.

Once an event is detected, the ALM rectangle (fig. 5.11) blinks to signal an alert. This section may also be reached at all times by pressing on the ALM button (button 3 in fig. 5.10).

Press the BACK button (button 4 in the example in fig. 5.12) to return to the main menu screen.

Control Panel

F2 – Alerts

MINOR ALERTS						
Alert	Event	Action	UP travel	DOWN travel	Unit LOCKED	
10 FOOT STOP 3 SEC STOP TO VERIFY ALL CLEAR UNDER PLATFORM	Going DOWN , unit stops for 3 seconds	Make sure there are no interferences under the platform Used in transport platform configurations	NOT ALLOWED	NOT ALLOWED	NO	
BOTTOM LIMIT UPWARD TRAVEL ONLY	Going DOWN , unit stops	Bottom limit reached; only upward travel allowed	ALLOWED	NOT ALLOWED	NO	
COMMUNICATION ERROR	Unit stops	COMMUNICATION option must be disabled	NOT ALLOWED	NOT ALLOWED	NO	
DOOR STATUS	Unit stops	Check all doors on the installation and make sure they are closed properly	NOT ALLOWED	NOT ALLOWED	NO	
INCL L > 2DEG POS GO UP OR DOWN TO LEVEL	Going UP , unit keeps moving Going DOWN , unit stops	INCL L option must be disabled	ALLOWED	NOT ALLOWED	NO	
INCL L > 2DEG NEG GO UP OR DOWN TO LEVEL	Going UP , unit stops Going DOWN , unit keeps moving	INCL L option must be disabled	NOT ALLOWED	ALLOWED	NO	
INCL R > 2DEG POS GO UP OR DOWN TO LEVEL	Going UP , unit keeps moving Going DOWN , unit stops	INCL R option must be disabled	ALLOWED	NOT ALLOWED	NO	
INCL R > 2DEG NEG GO UP OR DOWN TO LEVEL	Going UP , unit stops Going DOWN , unit keeps moving	INCL R option must be disabled	NOT ALLOWED	ALLOWED	NO	
REMOTE PANEL ALARM SEE REMOTE PANEL REMOTE PANEL OFFLINE	Unit stops when communication is used	COMMUNICATION option must be disabled	NOT ALLOWED	NOT ALLOWED	NO	
REMOTE PANEL LOCK ENTER PASSWORD	Unit stops	COMMUNICATION option must be disabled	NOT ALLOWED	NOT ALLOWED	NO	
TOP LIMIT DOWNWARD TRAVEL ONLY	Going UP , unit stops	Top limit reached; only downward travel allowed	NOT ALLOWED	ALLOWED	NO	

fig. 5.13

Note: Messages highlighted in rows greyed out in the table above result from an improper configuration. The configuration options corresponding to the greyed out rows must be disabled for a transport platform application

Control Panel

F2 – Alerts

MAJOR ALERTS						
Alert	Event	Action	UP travel	DOWN travel	Unit LOCKED	
BOTTOM FINAL LIMIT NO MOVEMENT ALLOWED CONTACT TECHNICIAN	Going DOWN , unit stops	Inspect the bottom limit sensor and make sure it is working properly; alarm is related to signal of BFL mechanical limit switch	NOT ALLOWED	NOT ALLOWED	NO	
BOTTOM FINAL LIMIT FAULT UNIT LOCKED CONTACT TECHNICIAN	Unit stops; travel is not allowed	Unit is locked and must be reset by qualified E&D personnel or a qualified technician after inspection	NOT ALLOWED	NOT ALLOWED	YES	
ELEC PHASE DETECTOR CHECK PHASE SELECTOR CHECK MOTOR OVERLOAD	Travel is not allowed	Perform phase inversion (using phase selector on side of control panel) properly; shut down power and contact certified electrician or a qualified technician	NOT ALLOWED	NOT ALLOWED	NO	
INCL L > 5DEG POS GO UP OR DOWN TO LEVEL	Unit stops	INCL L option must be disabled	NOT ALLOWED	NOT ALLOWED	NO	
INCL L > 5DEG NEG GO UP OR DOWN TO LEVEL	Unit stops	INCL L option must be disabled	NOT ALLOWED	NOT ALLOWED	NO	
INCL R > 5DEG POS GO UP OR DOWN TO LEVEL	Unit stops	INCL R option must be disabled	NOT ALLOWED	NOT ALLOWED	NO	
INCL R > 5DEG NEG GO UP OR DOWN TO LEVEL	Unit stops	INCL R option must be disabled	NOT ALLOWED	NOT ALLOWED	NO	

fig. 5.14

Note: Messages highlighted in rows greyed out in the table above result from an improper configuration. The configuration options corresponding to the greyed out rows must be disabled for a transport platform application

Control Panel

F2 – Alerts

MAJOR ALERTS						
Alert	Event	Action	UP travel	DOWN travel	Unit LOCKED	
INPUT POWER FAULT RETURN TO BASE LEVEL ONLY	DOWNWARD travel only	Input voltage too low while unit is moving; return to base level; contact certified electrician and check input power	NOT ALLOWED	ALLOWED	NO	
OVER AMPERAGE DOWN CHECK POWER SOURCE OR LOAD	Going DOWN , unit stops	Amperage draw is too high while moving DOWN ; check load on platform as per configuration; check for mechanical obstruction	ALLOWED	NOT ALLOWED	NO	
OVER AMPERAGE UP CHECK POWER SOURCE OR LOAD	Going UP , unit stops	Amperage draw is too high while moving UP ; check load on platform as per configuration; check for mechanical obstruction	NOT ALLOWED	ALLOWED	NO	
OVER VOLTAGE (STAT) CHECK POWER SOURCE	Travel is not allowed	Input voltage too high; contact certified electrician and check input power	NOT ALLOWED	NOT ALLOWED	NO	
TOP FINAL LIMIT DOWNWARD TRAVEL ONLY CONTACT TECHNICIAN	Going up , unit stops; only DOWNWARD travel is allowed	Inspect the top limit sensor and make sure it is working properly; alarm is related to signal of TFL mechanical limit switch; only downward travel is allowed	NOT ALLOWED	ALLOWED	NO	
TOP FINAL LIMIT FAULT RETURN TO BASE LEVEL ONLY CONTACT TECHNICIAN	DOWNWARD travel only	Downward travel is allowed until bottom limit (BL) is reached; unit then locks up and must be reset by qualified E&D personnel or a qualified technician after inspection	NOT ALLOWED	ALLOWED	NO	
TOP FINAL LIMIT FAULT UNIT LOCKED CONTACT TECHNICIAN	Unit is locked; travel is not allowed	Unit is locked and must be reset by qualified E&D personnel or a qualified technician after inspection	NOT ALLOWED	NOT ALLOWED	YES	
UNDER VOLTAGE (STAT) CHECK POWER SOURCE	Travel is not allowed	Input voltage too low; contact certified electrician and check input power	NOT ALLOWED	NOT ALLOWED	NO	

fig. 5.15

Control Panel

F2 – Alerts

Quick Reference Table – Minor Alerts

MINOR ALERTS			
10 FOOT STOP 3 SEC STOP TO VERIFY ALL CLEAR UNDER PLATFORM			
BOTTOM LIMIT UPWARD TRAVEL ONLY			
COMMUNICATION ERROR COMMUNICATION MUST BE DISABLED			
DOOR STATUS			
INCL L > 2DEG POS INCL L OPTION MUST BE DISABLED			
INCL L > 2DEG NEG INCL L OPTION MUST BE DISABLED			
INCL R > 2DEG POS INCL R OPTION MUST BE DISABLED			
INCL R > 2DEG NEG INCL R OPTION MUST BE DISABLED			
REMOTE PANEL ALARM COMMUNICATION MUST BE DISABLED			
REMOTE PANEL LOCK COMMUNICATION MUST BE DISABLED			
TOP LIMIT DOWNWARD TRAVEL ONLY			

fig. 5.17

Note: Messages highlighted in rows greyed out in the table above result from an improper configuration. The configuration options corresponding to the greyed out rows must be disabled for a transport platform application

LEGEND	
ICON	DEFINITION
OR	Alert (yellow for minor, red for major)
	UPWARD travel is allowed
	DOWNWARD travel is allowed
	Not allowed
	Unit is locked
	Qualified personnel
	Certified electrician
	Qualified E&D personnel or qualified technician

fig. 5.16

Control Panel

F2 – Alerts

Quick Reference Tables – Major Alerts

MAJOR ALERTS				MAJOR ALERTS			
BOTTOM FINAL LIMIT NO MOVEMENT ALLOWED CONTACT TECHNICIAN	×	×		INPUT POWER FAULT RETURN TO BASE LEVEL ONLY	×		
BOTTOM FINAL LIMIT FAULT UNIT LOCKED CONTACT TECHNICIAN	×			OVER AMPERAGE DOWN CHECK POWER SOURCE OR LOAD			
ELEC PHASE DETECTOR CHANGE PHASE SELECTOR CHECK MOTOR OVERLOAD	×			OVER AMPERAGE UP CHECK POWER SOURCE OR LOAD	×		
INCL L > 5DEG POS <i>INCL R OPTION MUST BE DISABLED</i>	×			OVER VOLTAGE (STAT) CHECK POWER SOURCE	×		
INCL L > 5DEG NEG <i>INCL R OPTION MUST BE DISABLED</i>	×			TOP FINAL LIMIT DOWNWARD TRAVEL ONLY CONTACT TECHNICIAN			
INCL R > 5DEG POS <i>INCL R OPTION MUST BE DISABLED</i>	×			TOP FINAL LIMIT FAULT RETURN TO BASE LEVEL ONLY CONTACT TECHNICIAN	×		
INCL R > 5DEG NEG <i>INCL R OPTION MUST BE DISABLED</i>	×			TOP FINAL LIMIT FAULT UNIT LOCKED CONTACT TECHNICIAN	×		
				UNDER VOLTAGE (STAT) CHECK POWER SOURCE	×		

fig. 5.19

fig. 5.18

Note: Messages highlighted in rows greyed out in the table above result from an improper configuration. The configuration options corresponding to the greyed out rows must be disabled for a transport platform application

Control Panel

Screen alerts and instructions

F3 – Inputs and outputs

Access level: User / Operator

This section displays information about the various controls, sensors and switches linked to the input and output ports of the control panel. A black circle will indicate that the control panel receives a signal from a sensor or sends a signal to an actuator. Other information will be displayed in values. These pages are mainly useful for troubleshooting operations to provide information on the condition of the unit and the setup to a remote qualified technician.



fig. 5.20



fig. 5.21



fig. 5.22



fig. 5.23

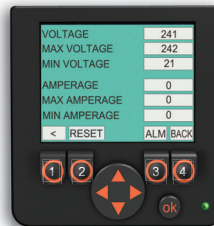

fig. 5.24

Note: Numbers on the above option buttons are displayed as an example only. Actual messages displayed may differ from picture.

- 1- Press the F3 button on the main menu page (button 3 in fig. 5.7, p. 55).
- 2- Change display pages with the option buttons (buttons 1 and 2 in fig. 5.21).
- 3- Press the BACK button (button 4 in fig. 5.21) to return to the main menu page.

F4 – Configuration

Access level: Erector / Dismantler

This four-page section includes: one access code entry page for this section (accessible only to Erector / Dismantler level) and two pages for the modification of setup configuration options. The last page of the section is an access code entry page giving access to options available only to a qualified technician.

- 1- Press the F4 button on the main menu page (button 4 in fig. 5.7, p. 55).
- 2- On the access code entry page, press on the OK button. Once the input box is blinking, use the UP and DOWN arrows (on the navigation button) to change the value (access code available only to the qualified erector/dismantler), then press OK to access the configuration options section pages.
- 3- Change display pages with the option buttons (buttons 1 and 2 in fig. 5.26).
- 4- Use the UP and DOWN arrows on the navigation button to reach the box to be modified.
- 5- Press the OK button to select the box to be modified.
- 6- Once the selected box is blinking, use the UP and DOWN arrows on the navigation button to change the value displayed in the box and set it to the required value.

Control Panel

Screen alerts and instructions

F4 – Configuration

Access level: Erector / Dismantler

- 7- Press the OK button to confirm the change.
- 8- Press the BACK button (button 4 in fig. 5.26) to return to the main menu page. Access to the configuration options section will automatically be deactivated once the user leaves the section. The access code to access this level will need to be entered again.

fig. 5.25



fig. 5.27



fig. 5.26

fig. 5.28



Note: Numbers on the above option buttons are displayed as an example only. Actual messages displayed may differ from picture.

Performing a position reset

It is required to perform a position reset of the motorized unit when adjusting the bottom final limit switch or after triggering the bottom final or top final limit. If a final limit (bottom or top) was triggered, the incident must be investigated before operation of the motorized unit can resume. The adjustment of the bottom final limit switch and the position reset of the motorized unit **must be performed only by a qualified erector/dismantler or a qualified technician**. For the definition of a qualified erector/dismantler or a qualified technician, refer to p. 7 of the *Performance and Safety Rules* section.

- 1- Press the F4 button on the main menu page (button 4 in fig. 5.7, p. 55).
- 2- Change display pages with the option buttons (buttons 1 and 2 in fig. 5.29) to move to the page with the reset position box.
- 3- Press the OK button for the entry box to blink.
- 4- Use the UP and DOWN arrows on the navigation button to change the value displayed in the box (from NORMAL to RESET).
- 5- Press the OK button to confirm the change.
- 6- Resume operation of the motorized unit.



fig. 5.29

Preventing unauthorized operation of the motorized unit

In order to avoid unauthorized operation of the motorized unit, perform the following steps to lock the control panel:

- 1- Return to the main menu on the display screen.
- 2- Press twice on the OK button under the display screen to reach the access code entry page.
- 3- Press on one of the bottom left buttons to log out of the screen.



fig. 5.30



fig. 5.31



fig. 5.32

Control Panel

Screen alerts and instructions

F4 – Configuration

Access level: Erector / Dismantler

fig. 5.33

Option	Choice	Description
1 DOOR SWITCH1	ENABLE/DISABLE	OPTION MUST BE ENABLED
2 DOOR SWITCH2	ENABLE/DISABLE	OPTION MUST BE ENABLED
3 INCLINOMETER L	ENABLE/DISABLE	OPTION MUST BE DISABLED
4 INCLINOMETER R	ENABLE/DISABLE	OPTION MUST BE DISABLED
5 COMMUNICATION	ENABLE L/ENABLE R/ DISABLE	OPTION MUST BE DISABLED
6 OPERATOR PWD	VALUE	Option available to erector/dismantler to modify operator (entry level) password
7 PASSWORD	ENABLE/DISABLE	Option to enable or disable the operator password (entry level); when DISABLED, other means must be put in place to prevent unauthorized operation when the operator is not present
8 LEVEL1	VALUE	Option available to qualified E&D personnel to modify Level 1 E&D password
9 RESET RUNTIME	NORMAL/RESET	Option to reset the runtime counter of the unit
10 RESET POSITION	NORMAL/RESET	Option to reset position of motorized unit USED WHEN A BOTTOM OR TOP FINAL LIMIT HAS BEEN TRIGGERED

Note: Messages highlighted in rows greyed out in the table above result from an improper configuration. The configuration options corresponding to the greyed out rows must be disabled for a transport platform application

Connection of the remote control pendant

The remote control pendant is used to replicate the rise and descent selector and the emergency stop of the control panel for an S Series transport platform with car setup.

- 1- Remove the protective cap from the connection port on the left side of the panel and connect the control pendant.
- 2- Make sure the control pendant selector is enabled (set to "ENABLED"), as shown in fig. 5.35.

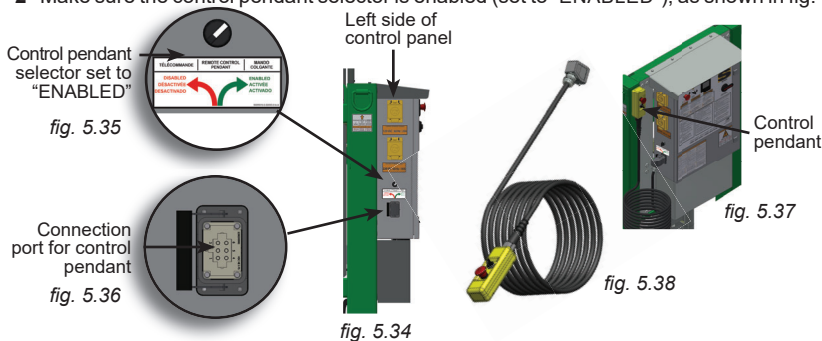

Mast and Mast Ties

Mast Sections

The handling, installation and removal of mast sections must be performed with care to avoid mishaps that may lead to safety issues. Mast sections must be handled properly and with care to avoid damages to the racks.

Installation of a single mast section

- 1- Make sure that the motorized unit is positioned properly. Refer to p. 15 of the *Transport Platform System* section for more information.
- 2- Refer to applicable local regulations governing distances between the mast climbing work platform system and electrical lines.
- 3- Remove the two mast heads (fig. 6.2).
- 4- Using an optional jib arm (see p. 77 of the *Accessories* section) or any other appropriate lifting device such as a crane or a rough terrain forklift, lift and carry the next mast section on top of the bottom mast section.
- 5- Make sure that the rack of the mast section is on the **rear side** (fig. 6.2) and aligned with the rack on the bottom mast section. It is recommended to handle mast sections carefully so as not to damage the mast rack(s).
- 6- Make sure the spring pins on the racks are in good condition and properly aligned, and that the mast sections are connected together (fig. 6.1).
- 7- Using 1"-8 x 8" GR8 bolts and 1" GR8 lock nuts, bolt all four corners together, making sure the bolt heads are facing down. Tighten the four bolt and nut assemblies with a torque of 150 lb-ft (203 N-m) to secure the mast section in place.
- 8- Repeat steps 4 through 7 for each mast section.

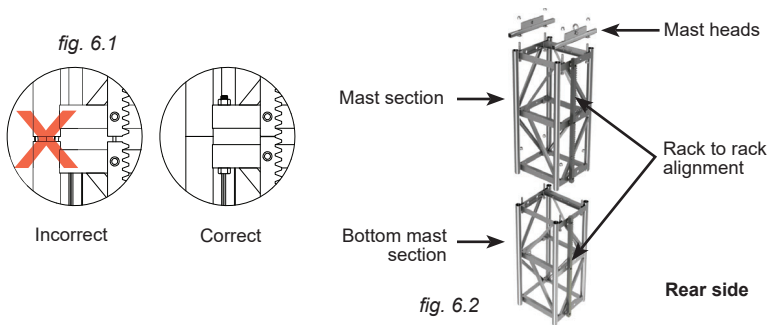

- 9- Make sure that the rack is sufficiently greased along the whole length of the mast. **On initial setup and subsequently after every eight to ten hours of cumulative runtime** (with unit traveling up and down the mast), grease must be applied to the gears, and to the rack(s) from the top of the mast down. For more information, refer to the daily inspection checklist recommended for this motorized unit. If an **aerosol open gear lubricant** is used, **grease must be allowed to stand for 2-3 hours** before the motorized unit is used again. Use an open gear lubricant recommended by Hydro Mobile. Refer to p. 91 of the *Transport, Storage and Maintenance* section for more information on the appropriate lubrication method.
- 10- Install the two mast heads on the last mast section and keep them in place until the setup is dismantled. If mast heads are not used, make sure that the last mast section has **no rack** or **only one rack** that is **toward the face of the work**.



NOTICE

It is critical to inspect, clean and grease the gears and rack(s) of a Hydro Mobile S Series transport platform system following the recommended inspection schedules. Failure to clean and grease the gears and rack(s) properly and in a timely fashion can lead to equipment damage and premature wear of the gears, the rack and pinion.

Mast and Mast Ties

Mast Sections

Installation of a single mast section (cont'd)

11- For instructions on the installation of assembled lengths of mast sections, refer to the installation instructions on p. 25 of the *Transport Platform System* section and to the instructions on the use of the multiple mast handler on p. 86 of the *Accessories* section.

Removal of a single mast section

- 1- To remove one mast section, make sure the two mast heads have been removed. Mast sections must be handled carefully so as not to damage the mast rack.
- 2- Remove the four bolt assemblies joining the top mast section to the bottom one and, using an optional jib arm or any other appropriate lifting device such as a crane or a rough terrain forklift, lift the top mast section off the bottom mast section.
- 3- Carefully store the mast section vertically inside the transport platform car. It is important to refer to the dismantling instructions on p. 26 of the *Transport Platform System* section for the maximum load allowed inside the transport platform car during dismantling operations.
- 4- For instructions on the removal of assembled lengths of mast sections and information regarding the maximum load allowed during dismantling operations, refer to the dismantling instructions on p. 32 of the *Transport Platform System* section and to the instructions on the use of the multiple mast handler on p. 86 of the *Accessories* section.

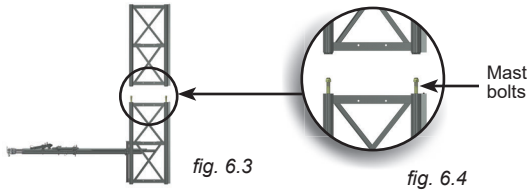

Transport and storage of mast sections

- 1- For best results when transporting mast sections in horizontal bundles, it is recommended to strap them in groups of three (3), lying on a side which has no rack.
- 2- Mast sections must be stored on a flat surface, vertically or lying horizontally on a side which has no rack, away from work areas and construction traffic.

Pre-installation of tie levels

General guidelines

- 1- The pre-installation of all tie levels is mandatory for an S Series transport platform with car system and consists in the installation of all mast sections and tie levels necessary to reach the full height of the mast, as required and allowed, **before** passing the installation for use and beginning normal operation of the setup.
- 2- The **installation of the first two mast tie levels** must be done using **other means of access than the motorized unit**. The **motorized unit must rest on the buffers on the base until at least two mast tie levels** are completely installed.
For more information, refer to the installation instructions beginning on p. 15 of the *Transport Platform System* section.
- 3- The S Series transport platform with car system must not be used on mast with a height over 500' (152 m). To maximize efficiency and because of the speed of travel, it is recommended to use the S Series transport platform with car system on a mast with a height of 200' (61 m) or less.



WARNING

Transport platform components (car, rear and lateral extensions) must not be installed until at least two tie levels are installed.

It is mandatory to **install all required tie levels** up to the top of the setup following the schedule of installation **before** passing the installation for use and starting any work. Failure to install all tie levels as required by the mast tie schedule for an S Series transport platform with car application before starting any work could compromise the integrity of the installation, leading to serious injury or death.

Mast and Mast Ties

Pre-installation of tie levels

Calculating the proper sequence for tie level distribution

The installation of tie levels for an S Series transport platform with car system must be performed according to what is allowed by the *Mast Tie Schedule*, on p. 70.

The distribution of tie levels is crucial to limit reaction in the ties and stress on the mast. A progressive increase or decrease in tie level spacings ensures limited reaction. Since the configuration of a structure or a building may require the installation of tie levels at irregular spacings, it is important to calculate the **difference between tie spacings** to make sure that it is **never greater than 15' (4,6 m)**, whether spacings increase or decrease. It is also important to make sure that the tie spacing is appropriate according to the mast tie schedule.

For example, with the first two tie levels installed respectively at 15' (4,6 m) ("B" in fig. 6.5) and 35' (10,7 m) ("C" in fig. 6.5), tie spacings total 15' (4,6 m) from A to B, and 20' (6,1 m) from B to C as shown in fig. 6.5. The difference between those two tie spacings comes to **5' (1,5 m)**, which is within the acceptable range.

A third tie level can be installed 5' (1,5 m) above the second tie level (scenario "1" below) but no higher than 30' (9,1 m) above the second tie level (scenario "4" below), to remain within the range specified by the mast tie schedule, even though the difference between tie spacings would be within the acceptable tie spacing difference, as shown in fig. 6.5.

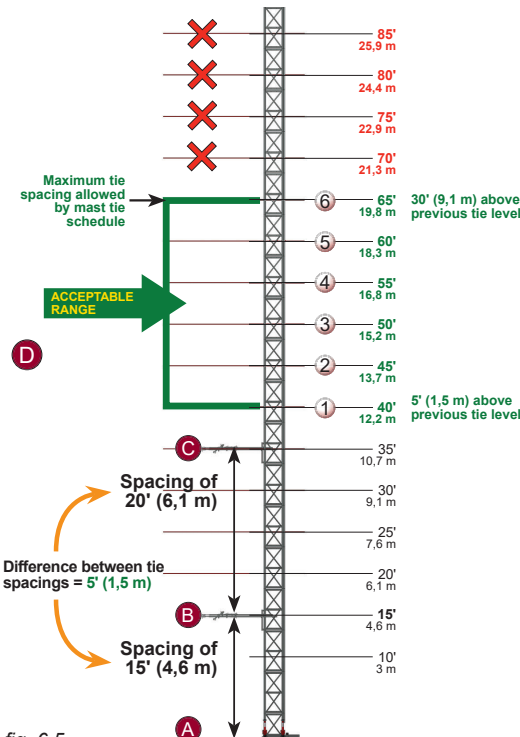

fig. 6.5

6

Spacing area	Tie distances	Difference between tie spacings
C to D	30' (9,1 m)	10' (6,1 m)
B to C	20' (6,1 m)	
B to C	20' (6,1 m)	5' (1,5 m)
A to B	15' (4,6 m)	

OR

5

Spacing area	Tie distances	Difference between tie spacings
C to D	25' (7,6 m)	5' (1,5 m)
B to C	20' (6,1 m)	
B to C	20' (6,1 m)	5' (1,5 m)
A to B	15' (4,6 m)	

OR

4

Spacing area	Tie distances	Difference between tie spacings
C to D	20' (6,1 m)	0
B to C	20' (6,1 m)	
B to C	20' (6,1 m)	5' (1,5 m)
A to B	15' (4,6 m)	

OR

1

Spacing area	Tie distances	Difference between tie spacings
C to D	5' (4,6 m)	15' (4,6 m)
B to C	20' (6,1 m)	
B to C	20' (6,1 m)	5' (1,5 m)
A to B	15' (4,6 m)	

OR

2

Spacing area	Tie distances	Difference between tie spacings
C to D	10' (3 m)	10' (3 m)
B to C	20' (6,1 m)	
B to C	20' (6,1 m)	5' (1,5 m)
A to B	15' (4,6 m)	

OR

3

Spacing area	Tie distances	Difference between tie spacings
C to D	15' (4,6 m)	5' (1,5 m)
B to C	20' (6,1 m)	
B to C	20' (6,1 m)	5' (1,5 m)
A to B	15' (4,6 m)	

Mast and Mast Ties

Pre-installation of tie levels

Calculating the proper sequence for tie level distribution (cont'd)

Structure or building configurations may require the installation of tie levels at varied spacings that increase as the installation goes up in height. Example in fig. 6.6 shows proper increase in tie spacings while fig. 6.7 shows improper increases in tie level spacings. While tie spacings in fig. 6.7 are within what is required by the mast tie schedule, the difference between tie spacing B to C and C to D is not within the acceptable range of tie spacing difference.

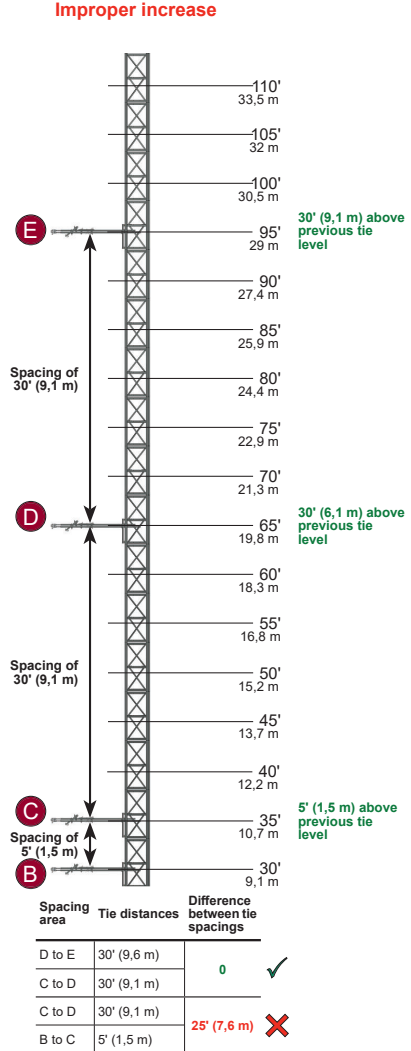
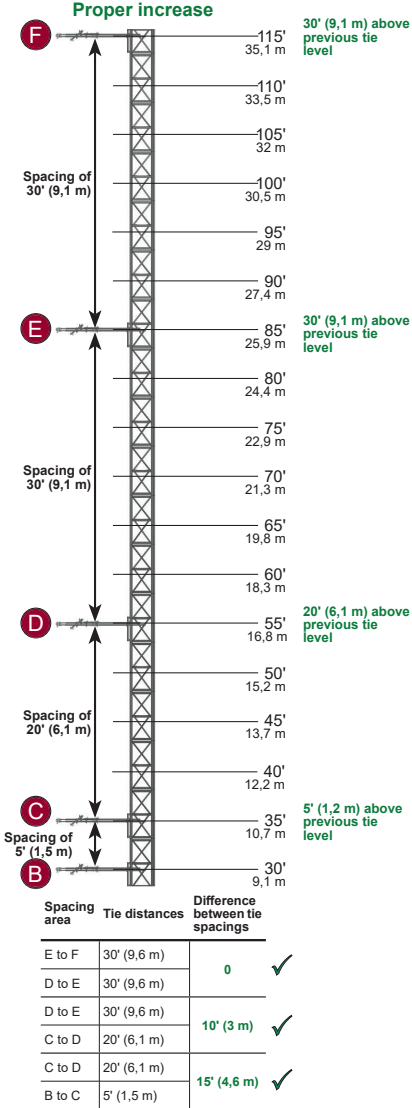

fig. 6.7

fig. 6.6

Examples above starting above first tie level "A" (not shown) installed at 15' (4,6 m) above base level.

Mast and Mast Ties

Pre-installation of tie levels

Calculating the proper sequence for tie level distribution (cont'd)

Structure or building configurations may require the installation of tie levels at varied spacings that decrease as the installation goes up in height. Example in fig. 6.8 shows proper decrease in tie spacings while fig. 6.9 shows improper decreases in tie level spacings. While tie spacings in fig. 6.9 are within what is required by the mast tie schedule, the difference between tie spacing B to C and C to D is not within the acceptable range of tie spacing difference.

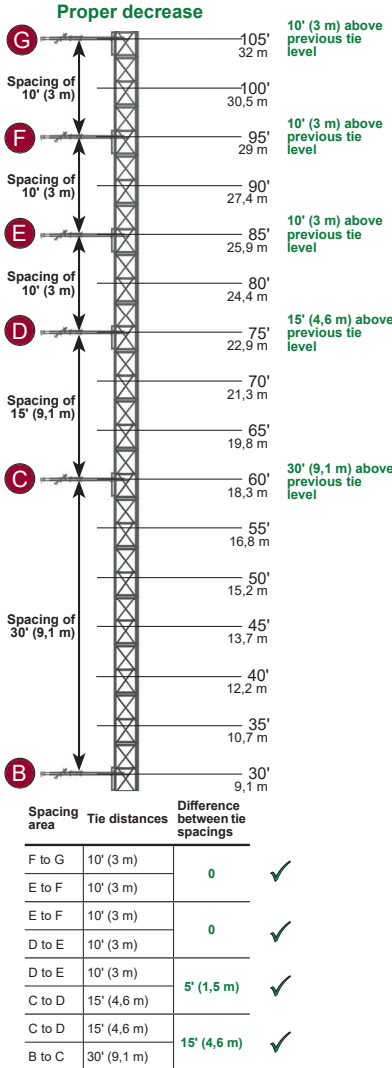

fig. 6.8

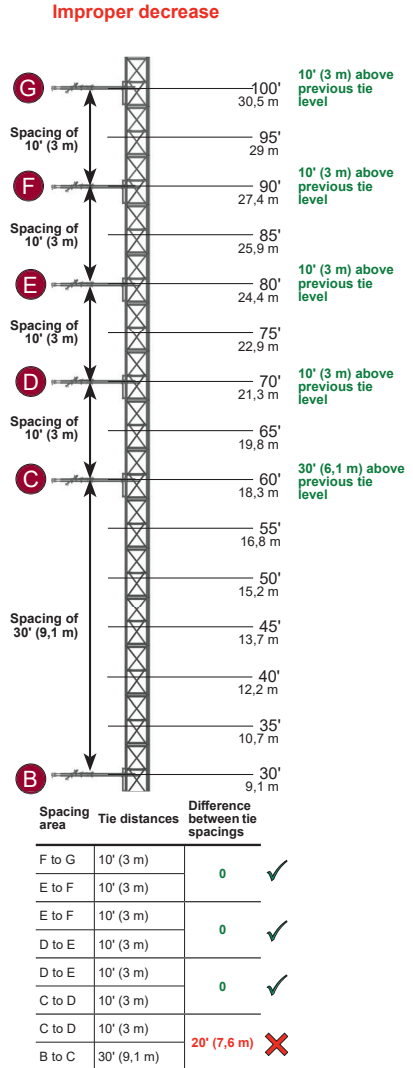

fig. 6.9

Examples above starting above first tie level "A" (not shown) installed at 15' (4,6 m) above base level.

Mast and Mast Ties

Pre-installation of tie levels

fig. 6.10

Mast Tie Schedule		
NO FREESTANDING ALLOWED		
THE PRE-INSTALLATION OF ALL TIE LEVELS IS MANDATORY		
A	A (from under base)	Between 10' (3 m) and 20' (6,1 m)
B	B (from A)	Between 10' (3 m) and 20' (6,1 m)
C	C (from B) and subsequent	Up to 30' (9,1 m)
Maximum difference between tie level spacings		15' (4,6 m)
Height of mast above last tie level with two or more tie levels in place		10' (3 m)
Height of mast above last tie level with one tie level in place		NOT ALLOWED

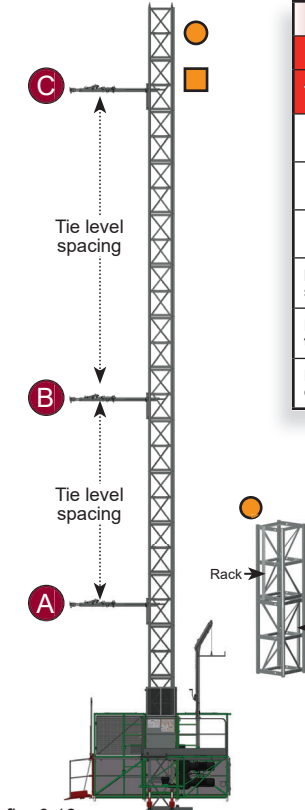

fig. 6.12

- Last mast section (installed **backwards** if no mast heads installed)
- Top limit trigger installed on next to last mast section

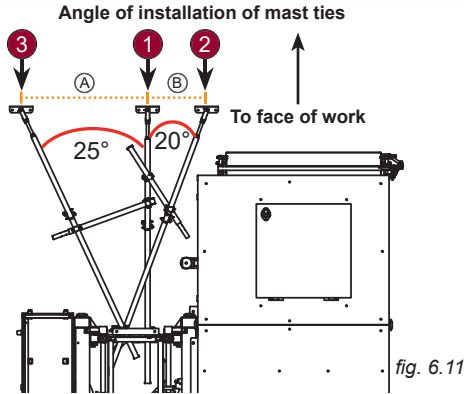

fig. 6.11

Recommended order of installation

- 1** Perpendicular mast tie to be installed first
- 2** Opposite angled mast tie to be installed second (angled at 20°)
- 3** Third mast tie to tighten the tie installation (angled at 25°)

Distance between wall ties

- A** 50 5/8" (129 cm)
 - B** 22 5/8" (57,5 cm)
- Distances in fig. 6.11 are given as a reference only. These distances apply to a setup installed at 85 1/2" (217,5 cm) from the face of the work with a required minimum overlap of 4" (10,5 cm).



WARNING

The **erection** and **dismantling** of a transport platform (including the motorized unit, the base, the car assembly, the extensions (rear and lateral), the masts, the mast ties and all the other components) must not be conducted when wind speeds exceed **28 mph (45 km/h)**. A transport platform **must not be operated** when wind speeds exceed **35 mph (56 km/h)**. It is important to inspect every component of a transport platform installation that has been exposed to winds exceeding 102 mph (164 km/h).

When the transport platform is not in use:

- The motorized unit must be brought down to base level
- All loads must be removed from the transport platform car

Mast and Mast Ties

Pre-installation of tie levels

Mast tie requirements

fig. 6.13

Mast Tie Requirements		
Ref	Component	Quantity
A	36" (91,5 cm) mast tie assembly	3
B	60" (152 cm) mast tie extension assembly	3
C	36" (91,5 cm) mast tie extension assembly	2
D	rigid dual clamps	9
E	wall tie brackets	3
F	swivel dual clamps	4

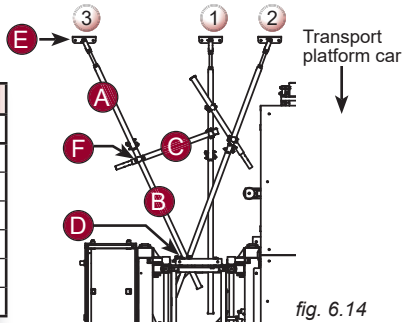

fig. 6.14

The installation of an S Series transport platform with car system requires the use of mast ties with extensions. It is **mandatory** to use mast tie braces, swivel dual clamps and additional clamps for such tie configurations.

Installation of mast ties with extensions

- 1- Align the holes on the mast tie frame with the holes on the mast section. Attach the mast tie frame to the mast section with assemblies of bolts, square washers, lock washers and nuts (4) (fig. 6.15). Tighten all bolt assemblies with a torque of 80 lb-ft (108 N-m).
- 2- Choose the appropriate anchoring system. For more information about the anchoring system, refer to p. 73 of this section.
- 3- Anchor the middle wall tie bracket to the building structure in the appropriate position ("1" in fig. 6.14), taking into account that the perpendicular mast tie must be installed on the tube inside the mast tie frame that is closest to the transport platform car.
- 4- Following the order of installation, anchor the other two wall tie brackets ("2" and "3" in fig. 6.14) at the angle of installation shown in fig. 6.11, p. 70.

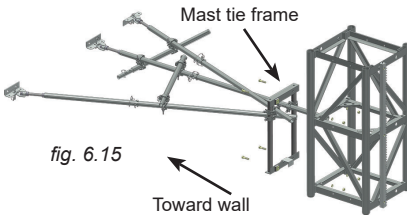

fig. 6.15

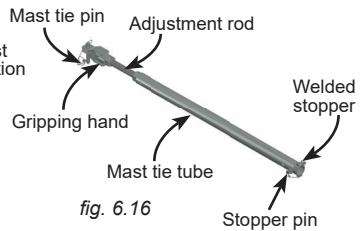

fig. 6.16

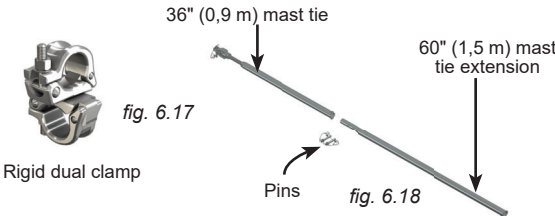

fig. 6.17

fig. 6.18

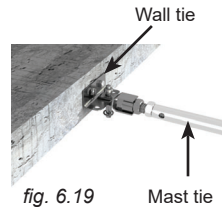

fig. 6.19

Mast and Mast Ties

Pre-installation of tie levels

Installation of mast ties with extensions (cont'd)

- 5- Insert a 60" (152 cm) mast tie extension into the tube of a 36" (91,5 cm) mast tie. Secure in place with two pins (fig. 6.18, p. 71).
- 6- Attach a rigid dual clamp to the vertical tube of the mast tie frame. Bolt assemblies must not be tightened yet.
- 7- Pin the gripping hand to the wall tie.
- 8- Align and insert the mast tie into the rigid dual clamp. Tighten the rigid dual clamp with a torque of 60 lb-ft (80 N-m).
- 9- Adjust the length of the adjustment rod until the mast is plumb on its **front** axis.
- 10- Install additional clamps on the mast tie, in **front** and **behind** the rigid dual clamp already installed on the mast tie frame. Tighten each clamp with a torque of 60 lb-ft (81 N-m).
- 11- Repeat steps 5 through 10 for the mast tie that is closest to the transport platform (shown as "2" in fig. 6.14, p. 71).
- 12- Adjust the length of the adjustment rod until the mast is plumb on **side** axis.
- 13- Repeat steps 5 through 10 to install the third mast tie.
- 14- Adjust the length of the adjustment rod on each of the mast ties until the mast is plumb on **both its front and side** axis.
- 15- Once the mast is plumb, brace the mast ties by installing 36" (91 cm) mast tie extensions secured to the mast tie assemblies with swivel dual clamps (fig. 6.21).
- 16- Make sure all clamps are tightened with a torque of 60 lb-ft (80 N-m).

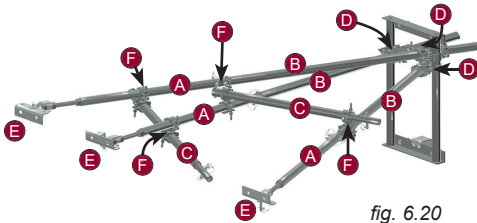

fig. 6.20

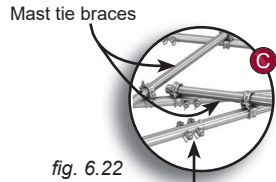

fig. 6.22

Mast tie extension secured to mast tie with two pins

- A 36" (91,5 cm) mast tie assembly
- B 60" (152 cm) mast tie extension assembly
- C 36" (91,5 cm) mast tie extension assembly
- D rigid dual clamps
- E wall tie brackets
- F swivel dual clamps



fig. 6.21

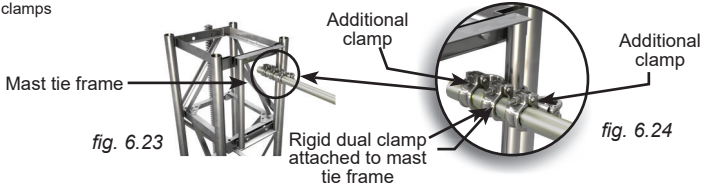

fig. 6.23

fig. 6.24



WARNING

It is important to verify each mast tie of an installation that has been exposed to winds exceeding 102 mph (164 km/h).



WARNING

When using mast ties without welded stoppers, use a bolt or an additional clamp as a stopper at the extremity of the mast tie tube attached to the mast tie frame.

Mast and Mast Ties

Pre-installation of tie levels

Removal of mast ties

- 1- Loosen the swivel dual clamps and remove the mast tie extensions installed as braces (fig. 6.26).
- 2- Beginning with one of the angled mast ties (see "1" in fig. 6.25), loosen the adjustment rod to release the tension. **It is mandatory to make sure that all tension (or compression) is released from the mast tie before attempting to loosen the clamp and unpin the mast tie from the wall tie.**
- 3- Remove the additional clamps installed in front and behind the rigid dual clamp installed on the mast tie frame.
- 4- Loosen the bolts on the rigid dual clamp holding the mast tie to the mast tie frame and unpin the mast tie from the wall tie. Remove the mast tie and the rigid dual clamp.
- 5- Repeat steps 2 through 4 for the other mast ties.
- 6- Once all mast ties are removed, uninstall the mast tie frame from the mast section.

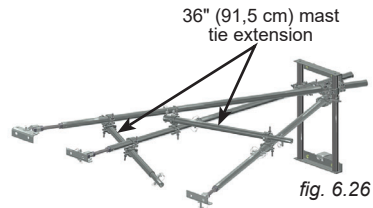
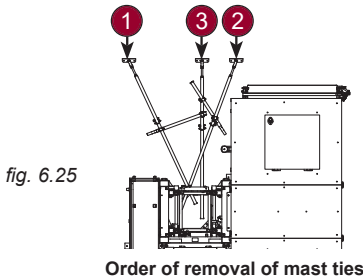

WARNING

It is mandatory to make sure that all tension (or compression) is released from the mast tie before attempting to loosen the clamp and unpin the mast tie from the wall tie.

Anchoring System

Wall tie reactions

Before attaching masts to the building using the mast tie system, wall ties must be installed on a solid component of the building structure. It is important to understand that whether the anchoring installation is a vertical or horizontal type (fig. 6.30 and fig. 6.31), values for tension / compression and shear forces will be **inverted**.

Concrete slabs, columns, steel beams, relief angles and other structural elements can be used provided they and the anchoring system chosen can sustain 3000 lb (1361 kg) of tension / compression and 1500 lb (680 kg) of shear force for a **vertical anchoring installation** and 1500 lb (680 kg) of tension / compression and 3000 lb (1361 kg) of shear force for a **horizontal anchoring installation**.

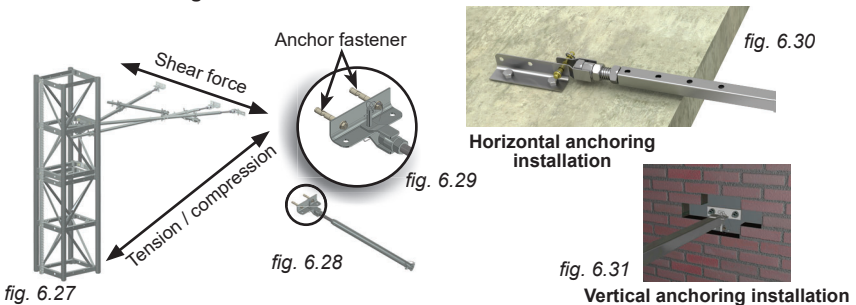

Each anchor fastener shown in fig. 6.29 must be able to sustain appropriate tension / compression and shear force for the application. Refer to p. 68 of this section for more information. A total of six anchor fasteners (minimum two per wall tie bracket) is required for each tie level.

Mast and Mast Ties Anchoring System

Installation guidelines for horizontal anchoring

Horizontal anchoring (fig. 6.30, p. 73) can only be installed at a 0° angle from horizontal. Wall ties used for horizontal anchoring installations must be able to sustain 1500 lb (680 kg) of tension/compression and 3000 lb (1361 kg) of shear force.

Installation of wall ties

Most anchor fastener manufacturers specify a maximum distance from the edge of a slab at which an anchor fastener must be installed to obtain its maximum working load. The thinner the slab, the less available area there is to obtain that working load.

In an S Series transport platform with car application tie installation, it is recommended to install the **wall tie located next to the transport platform car upside-down**, allowing a better horizontal alignment of all anchor fasteners in the center of the slab, as shown in fig. 6.33.

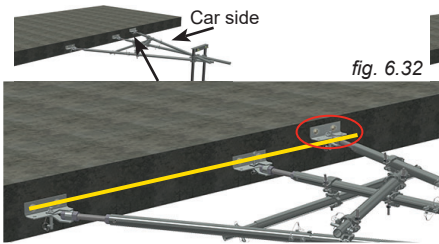

Vertical part of all wall ties installed upwards
Anchor fasteners do not align horizontally

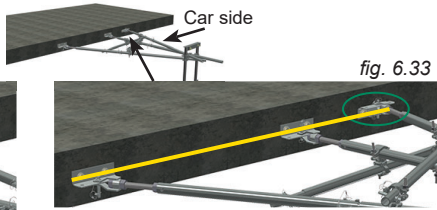

Vertical part of wall tie installed downwards on car side for better horizontal alignment of anchor fasteners



WARNING

It is mandatory to refer and conform to the anchor fastener manufacturer's specifications for the capacity, embedment, required distance from edge and application reduction factors of the fastener, manufacturer's recommended installation method, etc.

Wall tie types

There are 4 types of wall ties that can be used – welded, re-usable (centered or offset) and for horizontal/vertical installation. As the installation is rising, install the wall ties as per the appropriate mast tie schedule (see p. 70).



Welded wall tie



Re-usable wall tie (offset)



Re-usable wall tie (centered)



Wall tie for horizontal or vertical anchoring installation

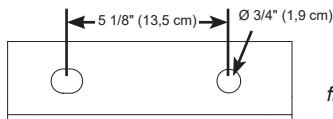

Drill-hole template for all wall ties

fig. 6.38



WARNING

It is important to note that fixed wall ties must not be used for transport platform applications.

Mast and Mast Ties

Anchoring System

Installation guidelines for a re-usable wall tie

The re-usable wall tie is installed in a wall cavity.

When dismantling the setup and removing mast ties, the re-usable wall tie is removed.

fig. 6.39



Installation of the re-usable wall tie

Installation guidelines for a welded wall tie on a beam

The welded wall tie is 6 7/8" (17,5 cm) long and must protrude from the beam by a maximum of 3 7/8" (10 cm). If an angled mast tie will be attached to the welded wall tie, the wall tie must be installed at the same angle as the mast tie.

When a welded wall tie is installed at an angle, as shown in fig. 6.42, the maximum length of 3 7/8" (10 cm) must be calculated on the longest side of the angled wall tie.

The welding electrode used must be E70-XX series.

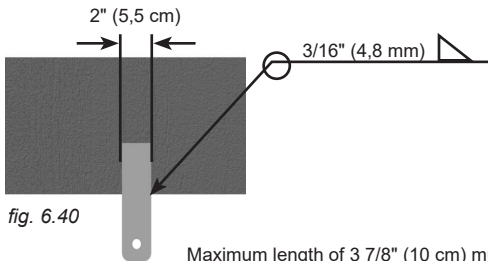

fig. 6.40

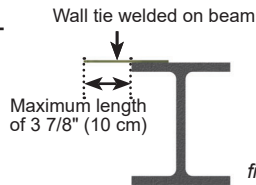

fig. 6.41

Maximum length of 3 7/8" (10 cm) must be measured on the longest side if the wall tie is at angle

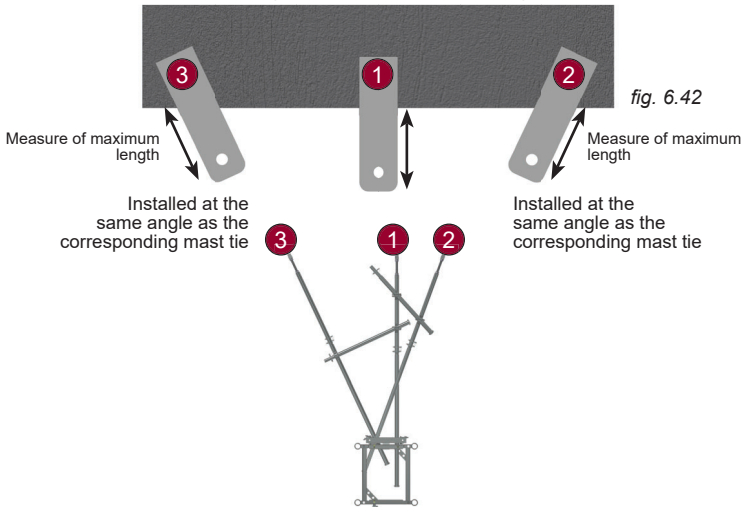

fig. 6.42

Load Capacities

General guidelines

- 1- To ensure safety and avoid creating any fall hazards, all platform gates and access panels on the transport platform must be closed when they are not in use and when the platform is moving. Transfer of workers and material must be safe and hazard-free. It is mandatory to install all necessary guardrails and to make sure that they are properly in place and secure at all times.
- 2- Make sure that materials carried in the car cannot move or shift when the transport platform is moving.
- 3- When the transport platform is moving, it is **mandatory** for all workers to stand inside the enclosed area of the platform. Nothing must overhang or be protruding from the transport platform enclosure **at all times** (material, body parts, etc.).
- 4- It is mandatory throughout the installation and dismantling of mast sections and tie levels to monitor the load inside the transport platform car and on the extensions (rear and lateral). The combined load of the jib arm (if used), each mast section, all tie level components, each worker, each plank for the mast tie installation deck and any other item present on the transport platform must be taken into account. Refer to and comply with the instructions of the selected method of installation (starting on p. 23 of the *Transport Platform System* section) and dismantling (starting on p. 30 of the *Transport Platform System* section) for the maximum E&D load allowed.
- 5- Each worker's weight (personal tools and equipment included) must be deducted from load capacities.
- 6- No load must be applied on a guardrail or a gate. Materials must be stored away from guardrails and gates. It is also forbidden for anyone to lean on a guardrail or a gate.
- 7- **The load capacities charts stickers displayed on the motorized unit used in the setup will take precedence over the information included in this owner's manual.**

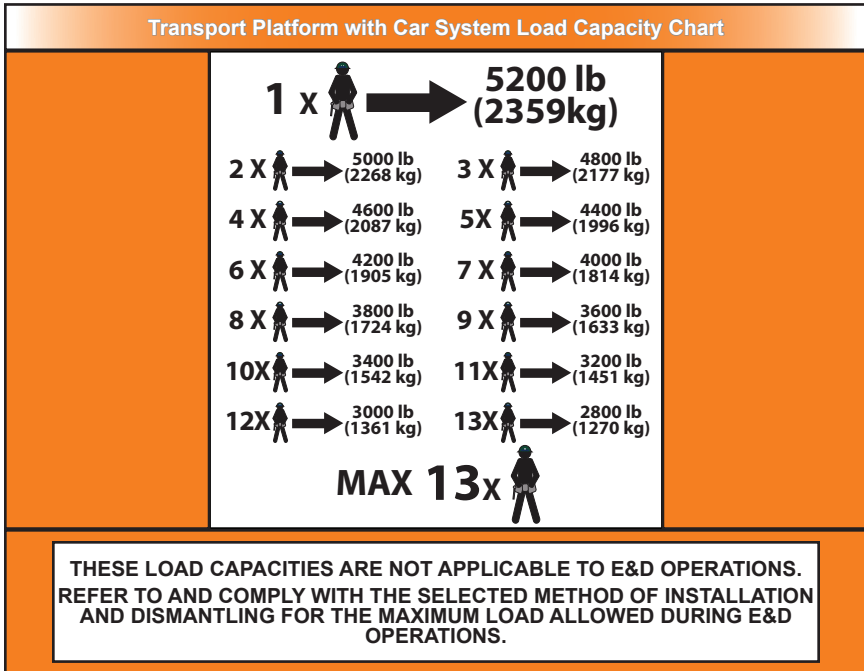

fig. 7.1

N	<p>NOTICE</p> <p>Make sure that materials carried in the car cannot move or shift when the transport platform is moving.</p>
----------	---

Jib Arm (optional)

The optional S Series jib arm is used to install or remove mast sections. The jib arm can be used with an interchangeable manual (factory-supplied) or electrical hoisting winch (not supplied by Hydro Mobile). With a maximum lifting capacity of 500 lb (226 kg), the jib arm must not be used to lift any material other than **one mast section at a time**.

Installation of the jib arm on the motorized unit

- 1- With the motorized unit at base level, remove the toggle pin and lift the cover plate of the jib arm pocket on the deck of the rear extension (fig. 8.5).
- 2- Lift the jib arm assembly and slide the bottom part in the guiding pocket attached to the transport platform car (fig. 8.5). It is recommended that the lift and installation of the jib arm assembly be handled by two persons.
- 3- Slide down the bottom part of the jib arm assembly into the jib arm pocket until it completely covers the pivot pin on the jib arm support plate, inside the rear extension (fig. 8.6).
- 4- Pivot the top part of the jib arm assembly (fig. 8.2) until it is completely upright. Secure in place with the toggle bolt. Tighten the bolt with a torque of 30 lb-ft (41 N-m). It is **mandatory** to make sure that the toggle bolt holding both parts of the jib arm together is tightened properly. Failure to tighten the bolt properly could result in equipment damage and lead to serious injuries, even death.

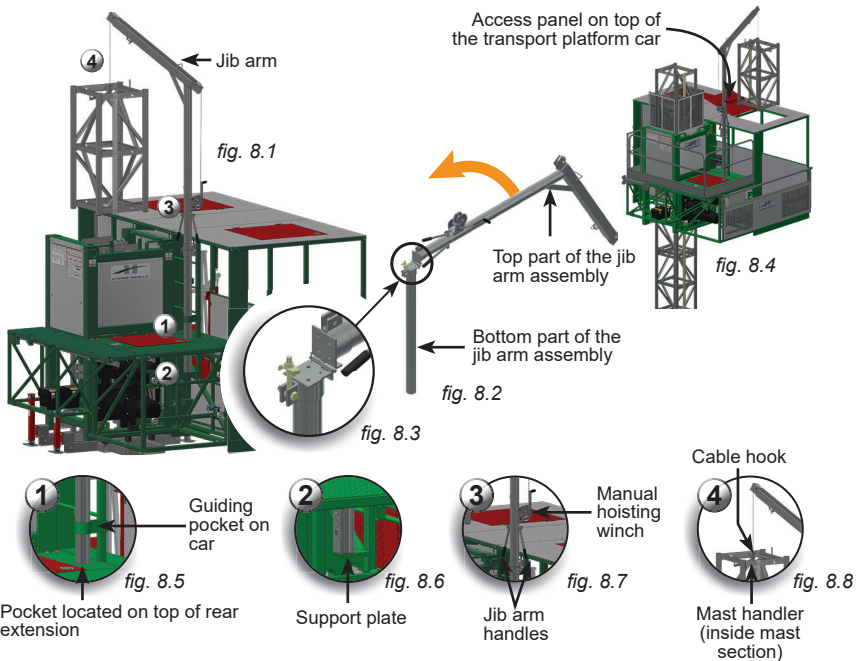

WARNING

It is **mandatory** to make sure that the toggle bolt holding both parts of the jib arm together is tightened properly. Failure to tighten the bolt properly could result in equipment damage and lead to serious injuries, even death. The hoisting device and the cable must be inspected before each use.

**Jib Arm
(optional)**

Using the jib arm to lift a mast section

- 5- Attach the mast handler to the cable hook at the upper end of the jib arm (fig. 8.8, p. 77).
- 6- Lower the cable inside the transport platform car through the rear access panel on top of the car and insert the mast handler diagonally under the top bar of the mast section to be lifted.
- 7- Lift and carry the mast section with the jib arm onto the top of the mast section that is already installed. Bolt the mast section in place (see p. 65 of the *Mast and Mast Ties* section for instructions).
- 8- Remove the mast handler from the top of the mast section **before** raising the platform.
- 9- Repeat steps 6 to 8 for each mast section to be installed until the setup is complete. Make sure to install tie levels as required and prescribed. For more information about tie levels, refer to p. 66 of the *Mast and Mast Ties* section.
- 10- Make sure the two mast heads are installed on top of the last mast section of the setup or that the last mast section of the setup has **no rack** or only **one rack** that is **toward the face of the work**.
- 11- Once the setup is complete and the motorized unit has been brought back to base level, remove the mast handler and the jib arm.
- 12- Replace the cover plate on the jib arm pocket and close the access panel on top of the transport platform car.

N	NOTICE
The jib arm has a maximum lifting capacity of 500 lb (226 kg) and must not be used to lift any material other than one mast section at a time . It is also important to remove the mast handler from the top of the mast section before raising the platform.	

**Mounting Bracket for Electric Chain Hoist
(optional)**

The optional mounting bracket (fig. 8.15, p. 79) can be installed on the S Series jib arm to allow the use of an electric chain hoist (not provided by Hydro Mobile) instead of the manual hoisting winch supplied with the jib arm.

It is important to keep in mind that the maximum lifting capacity of the Hydro Mobile jib arm is 500 lb (226 kg) and that the weight of the electric chain hoist must be deducted from that maximum lifting capacity. The jib arm must be able to handle one mast section at a time weighing 365 lb (166 kg) if it has two racks, or weighing 330 lb (150 kg) if it has only one rack.

It is **mandatory** to select an electric chain hoist model that meets the following lifting and clearance requirements.

fig. 8.9

Minimum requirements for electric chain hoist	
Description	Requirement
Maximum lifting capacity of the hoist	1/2 ton or 1000 lb (454 kg)
Overall dimension ("A" in fig. 8.10)	24" (61 cm)
Minimum hook opening ("B" in fig. 8.11)	1 1/8" (3 cm)
Minimum lifting height (chain)	136" (345 cm)
Recommended minimum lifting height (chain):	180" (457 cm)

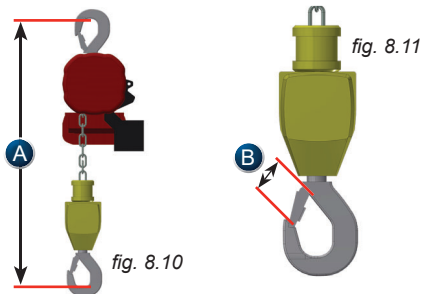

Electric chain hoist model shown for illustration purposes only

Mounting Bracket for Electric Chain Hoist (optional)

Clearance requirements for the electric chain hoist installation

Clearance between the motorized unit deck and the bottom of a mast section lifted by the jib arm (including the clearance required by the mast handler) must be adequate to allow the safe and efficient handling of mast sections.

fig. 8.12

Clearance Requirements	
Ref	Clearance
A	Maximum of 24" (61 cm)
B	Minimum of 60" (152 cm)
C	Minimum height of lift of 136" (345 cm) [recommended height of lift of 180" (457 cm)]
D	60" (152 cm)

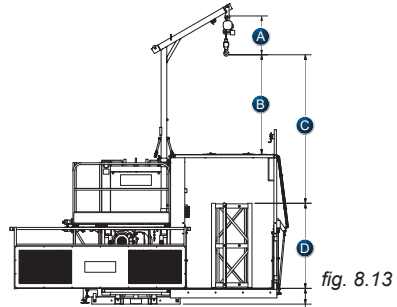

fig. 8.13

Installation of the mounting bracket

fig. 8.14

Components of the mounting bracket		
Ref	Component	Quantity
1	5/8"-11 x 4" (GR8) hexagonal bolt	2
2	5/8"-11 (GR8) nut with nylon insert	2
3	Galvanized, reversible mounting plate	2
4	Stopper on mounting plate	4
5	Galvanized spacer tube	1

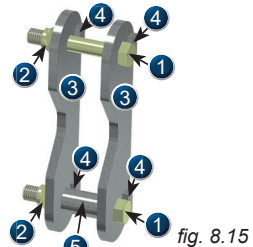
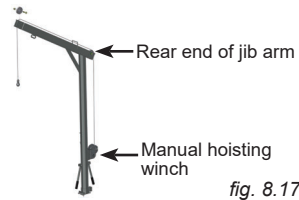
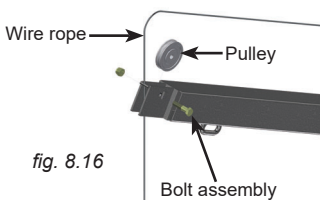

fig. 8.15

Mounting bracket (seen from rear)

- 1- Loosen the bolt assembly and remove the pulley at the end of the jib arm (fig. 8.16). Store the pulley and the bolt assembly properly.
- 2- If the manual hoisting winch must be uninstalled, remove the bolt assembly and the pulley at the rear end of the jib arm (fig. 8.17). Store the pulley and the bolt assembly properly.
- 3- Fully wind the wire rope of the manual hoisting winch.



- 4- Set the plates ("1" and "2", in fig. 8.20, p. 80) against the end of the jib arm, making sure that the welded stopper is on the appropriate side and that the profiled end of the plate is facing the rear end of the jib arm, as shown in fig. 8.18, p. 80. If the side of the jib arm has a stopper, there must be a stopper on the side of the plate that will be set against it, as shown in fig. 8.24, p. 80, as well as in fig. 8.20 and fig. 8.21, p. 80. It is important to note that the stopper will be located on the right-hand side on some jib arms and on the left-hand side on others. Installation must be adapted accordingly.

Mounting Bracket for Electric Chain Hoist (optional)

Installation of the mounting bracket (cont'd)

- 5- Insert the bolt in the top part ("3" in fig. 8.18 and in fig. 8.20), making sure the bolt head will be set against and secured by the stopper on the plate. Tighten the nut enough to make sure the assembly is snug against the jib arm. Avoid overtightening to allow the mounting bracket to pivot slightly on the bolt.
- 6- Insert the bolt in the bottom part of the first plate ("4" in fig. 8.18 and in fig. 8.20). Slide the spacer tube over the bolt, then push the bolt through the second plate.

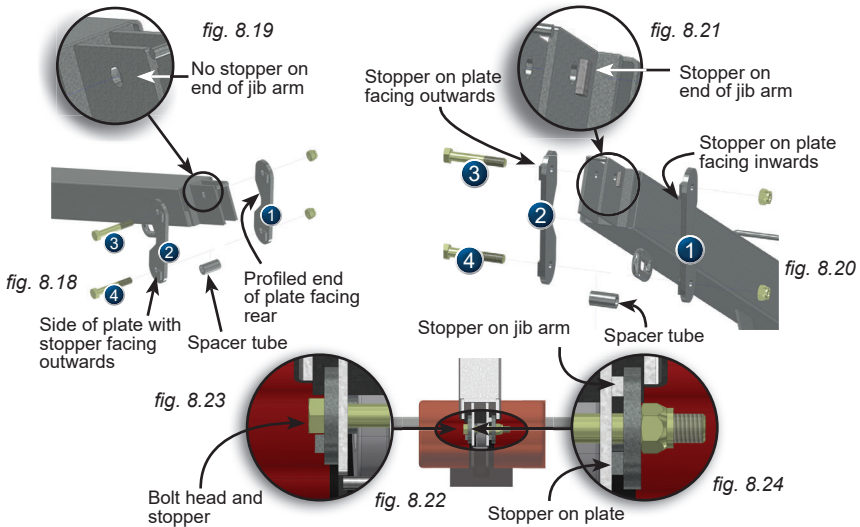

Installation of the electric chain hoist (not provided by Hydro Mobile)

- 7- Lift the electric chain hoist and hang its hook onto the spacer tube on the mounting bracket (fig. 8.25).

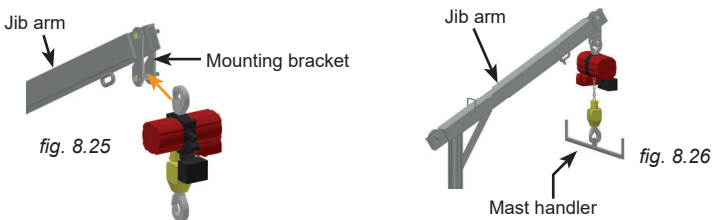

- 8- Connect the electric chain hoist to safe, reliable power source.
- 9- Install the mast handler (fig. 8.26). The electric chain hoist is now ready to use. It is mandatory to use the device according to the manufacturer's recommendations of use.
- 10- It is **mandatory** to refer to and comply with the capacities and limitations of the Hydro Mobile jib arm, as well as those of the electric chain hoist, as specified by its manufacturer. The most restrictive of those capacities and limitations will take precedence over the others.



NOTICE

It is **mandatory** to refer to and comply with the capacities and limitations of the Hydro Mobile jib arm, as well as those of the electric chain hoist, as specified by its manufacturer. The most restrictive of those capacities and limitations will take precedence over the others.

Cable Trolley (optional)

On a setup with a height over 150' (45,7 m), the use of the **optional cable trolley kit** is strongly recommended. The following installation instructions are for an installation with the transport platform car installed on the right side of the mast.

Installation

- 1- Select the appropriate power cable for the height of the setup. The cable trolley can only be used with a cable with a diameter of 1 1/4" (3,5 cm) or less. Refer to the *Power Cable Selection Chart* (fig. 4.1, p. 51) for help with the selection of the power cable. Make sure that the overall length of the cable is sufficient for the installation (height of setup, distance from power source, acceptable overall slack in cable).
- 2- Remove the three aluminum panels located on the main trolley: one panel located on the side opposite to the control panel, one panel located behind the mast and one under the electric panel.
- 3- Insert the motorized unit cable support bracket on the bottom horizontal tube of the main trolley that is located on the side opposite to the control panel at a distance of 15.5" (39,5 cm) from the front vertical tube (fig. 8.27). Secure the support in place with a bolt.

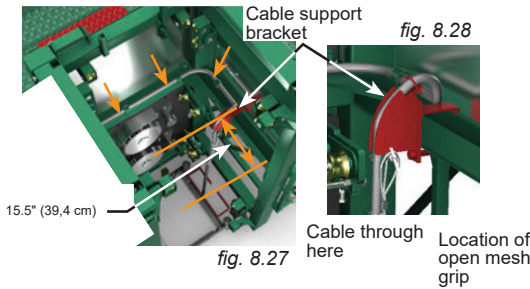

- 4- Run the power cable through the bottom of the main trolley and through the cable support. Then run the power cable along the bottom tubes of the main trolley around the back of the unit then to the control panel. Secure the cable to the main trolley tubes. Secure the cable to the cable support using the open mesh grip, making sure the length of the cable is sufficient for a proper hookup to the control panel and that the cable is not too taut.
- 5- Hook up the power cable to the control panel. **This installation must be performed by a certified electrician.**
- 6- Allow some slack in the cable behind the mast (fig. 8.29) to be able to adjust the tautness later.
- 7- Tie the cable to the chain links welded on the tubes of the main trolley. Tie the cable to the cable support bracket using the U-bolt provided.
- 8- Install the open mesh grip on the cable, making sure that the cable is not taut between the U-bolt and the open mesh grip. Hang the open mesh grip to the cable support bracket installed on the motorized unit.
- 9- Determine the operational length of the cable ("L1") by calculating the distance between the bottom part of the main trolley and the intended maximum height of the installation.
- 10- Determine the location for the installation of the second open mesh grip by calculating the distance ("L2") corresponding to the operational length of the cable ("L1") **PLUS 5' (1,5 m)** (fig. 8.30). Install the second open mesh grip at that location on the cable.
- 11- Hook the free end of the cable ("3", fig. 8.33, p. 82) to an appropriate power source. **This installation must be performed by a certified electrician.**

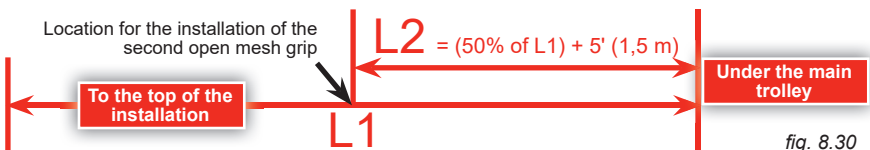

Cable Trolley (optional)

Installation (cont'd)

- 12- Loop the cable at the location of the second open mesh grip. Insert the loop through the lower part of the main trolley.
- 13- Temporarily hook the second open mesh grip on the top horizontal tube of the main trolley (fig. 8.31). Some S Series standard motorized units are equipped with a chain link welded to the top horizontal tube (shown in red in fig. 8.10) that can be used to hook the open mesh grip.
- 14- Make sure that cable segments 1 and 2 (fig. 8.33) are properly aligned for passing through the cable guides that will be installed on the whole length of the mast. Make sure also that segment 3 is properly inserted between the cable guide and the front tube of the mast (fig. 8.34).
- 15- Position the first cable guide on the middle bar of the second mast section, making sure it is positioned on the structure to be close to the tube located on the front of the mast (fig. 8.36), toward the face of the work. Secure in place with bolt assemblies.

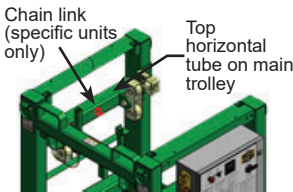

fig. 8.31

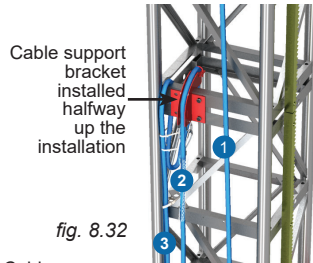

fig. 8.32

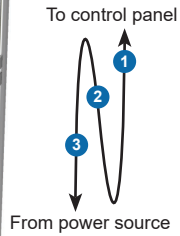

fig. 8.33

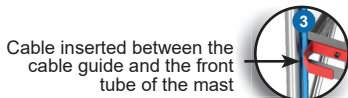

fig. 8.34

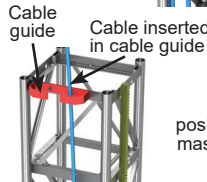

fig. 8.35

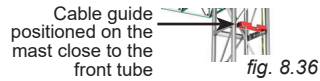

fig. 8.36

To face of work

- 16- Raise the motorized unit and install all the required, subsequent cable guides at every tie level, making sure that segments 1 and 2 of the cable (fig. 8.33) are properly inserted in each cable guide.
- 17- Continue raising the motorized unit until it has reached the junction between two mast sections that is located directly above the halfway mark of the final setup height (determined as "L2" in step 10). For example, if the final setup height will be 300' (91,4 m), the halfway mark will be the junction located directly above the 155' (47,2 m) mark.
- 18- Secure the halfway cable support bracket over the junction between two mast sections located directly above the halfway mark (fig. 8.32). Secure the support in place with bolt assemblies.
- 19- Unhook the cable from the horizontal tube on the main trolley (see step 13). Loop the portion of cable coming from the power source ("3", fig. 8.33) inside the mast section.
- 20- Run a portion of the cable going to the control panel ("2", fig. 8.32) through the support. Secure the cable in place with the U-bolt, making sure to allow some slack in the cable between the U-bolt and the open mesh grip.
- 21- Lower the unit toward base level. On the way down and at every other mast section, secure the segment of cable coming from the power source ("3", fig. 8.32) to the horizontal bar of the mast section. Make sure to secure the cable close to the tube located on the front of the mast (fig. 8.37, p. 83) so it can be properly inserted in the space between each cable guide and the tube located on the front of the mast.
- 22- Make sure that the cable segments going to the control panel ("1" and "2", fig. 8.32) is properly inserted in each cable guide (fig. 8.35).
- 23- Lower the motorized unit until it is about 6' (1,8 m) above base level.

Cable Trolley (optional)

Installation (cont'd)

- 24- Remove the bolt assemblies and bushings from the cable trolley (fig. 8.38).
- 25- Remove the snap ring to take out the wheel shaft and the guide wheel at one end of the cable trolley assembly (fig. 8.38).
- 26- Align the cable trolley with the mast so the pulley is in line with the power cable.
- 27- Tilt the assembly toward the inside of the mast so the pulley can be inserted in the opening between the tube on the front of the mast and the diagonal brace inside and the wheel guides can be properly snug against the mast tube (fig. 8.39).
- 28- Loop cable segments 1 and 2 (fig. 8.32, p. 82) around the pulley and let the cable trolley hang by gravity.
- 29- Reinstall the bushings and bolt assemblies to hold the cable in place, and reinstall the guide wheel (fig. 8.38).
- 30- To avoid crushing the cable trolley when bringing the unit down to base level, bolt the stopper (fig. 8.40) under the main trolley, in line with the buffers on the base.

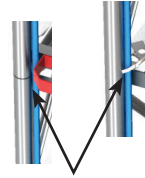

fig. 8.37

Cable is secured to the horizontal bar close to the front tube of the mast section so it can be inserted between the tube and each cable guide

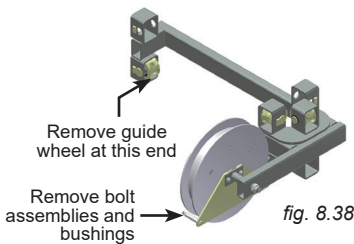

fig. 8.38



fig. 8.39

Make sure this end is properly snug against the structure and reinstall the guide wheel once the assembly is in place

Tilt the assembly to facilitate the insertion of the pulley

- 31- Adjust the height of the bottom limit trigger to make sure that when the motorized unit stops above the cable trolley when descending, there is at least a 3" (8 cm) clearance between the bottom of the stopper and the buffers on the base.
- 32- If necessary, make the required adjustments if the cable around the cable trolley becomes too loose or too tight.
- 33- Raise the motorized unit to the top of the installation, making sure along the way that the cable uncoils properly and is passing through each cable guide installed along the mast. On the way up, install all required, subsequent cable guides at each tie level between the halfway mark and the top of the installation.
- 34- Lower the motorized unit to base level and reinstall the panels removed in step 2.

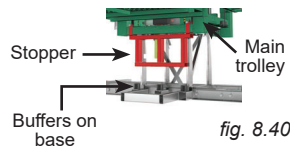

fig. 8.40

Movable Buffer Assembly (optional)

Base buffers are a safety component designed to stop the downward movement of the platform in the event of a failure to detect both the bottom limit and the bottom final limit or to stop the motorized unit during an emergency descent. The S Series motorized unit is equipped with base buffers. The use of base buffers is mandatory and specified by all applicable Mast Climbing Industry Standards (ANSI, CSA and ISO).

On different job sites, it is frequent that a motorized unit must be stopped at a level higher than the base to avoid possible interference with an obstacle (balconies, curvatures, columns, etc.) or a piece of equipment (such as a sidewalk canopy) located in the area under the unit.

In such conditions, it is mandatory to replace the buffers on the base with a movable buffer assembly in order to stop the downward movement of the platform at the required height in the event of a failure to detect both the bottom limit and the bottom final limit, or to stop the motorized unit during an emergency descent.

The installation of a movable buffer assembly must be performed by a **qualified erector/dismantler**. For the definition of a qualified erector/dismantler, refer to p. 7 of the *Performance and Safety Rules* section.

N	NOTICE
<p>The movable buffer assembly is designed to stop the downward movement of the platform beyond its normal travel limits in the event of a failure to detect both the bottom limit and the bottom final limit or to stop the motorized unit during an emergency descent. A movable buffer assembly must always be used in combination with a trigger for the bottom limit sensor and the bottom final limit sensor (or switch, depending on the series) which must be positioned above the movable buffer assembly.</p>	

Positioning the adapter plate

- 1- It is important to make sure that the position of the adapter plate is appropriate for an S Series motorized unit (fig. 8.41 and fig. 8.42). The arrow on the plate indicates that the "S" position is **toward** the mast (fig. 8.43).
- 2- To change the position of the adapter plate, remove the three bolts joining the adapter plate to the movable buffer assembly and position the plate appropriately. The positioning block (fig. 8.44) will prevent the alignment of the assembly holes if the plate is not oriented correctly. Rotate the plate by 180 degrees if the position block prevents installation of the adapter plate. Tighten each bolt on the adapter plate with a torque of 60 lb-ft (81 N-m).

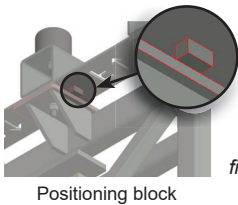
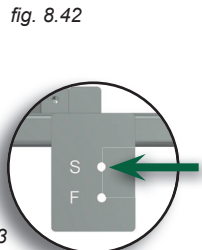
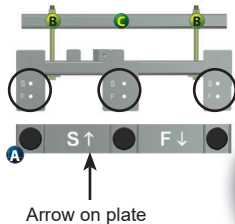
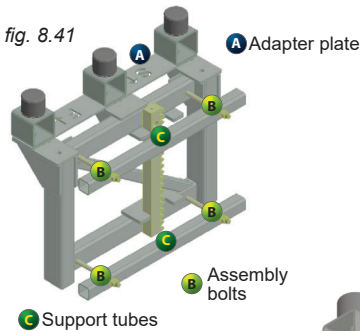

Movable Buffer Assembly (optional)

Installation of the movable buffer assembly

- Remove the four 5/8"-11 x 10" GR8 assembly bolts ("B" in fig. 8.41, p. 84) and the two support tubes ("C" in fig. 8.41, p. 84).
- Install the movable buffer assembly at the required height along the mast, using fig. 8.45 as a guide for the best position on a mast section for the installation. It is important to make sure to install the movable buffer assembly in the appropriate position to avoid any damages to the equipment.

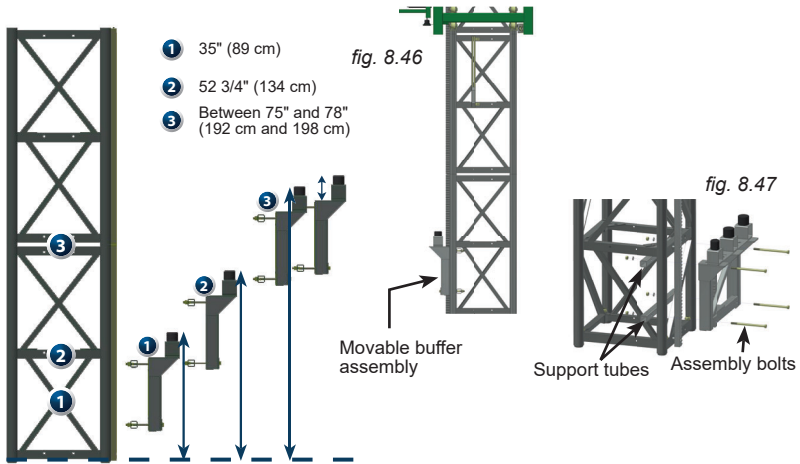
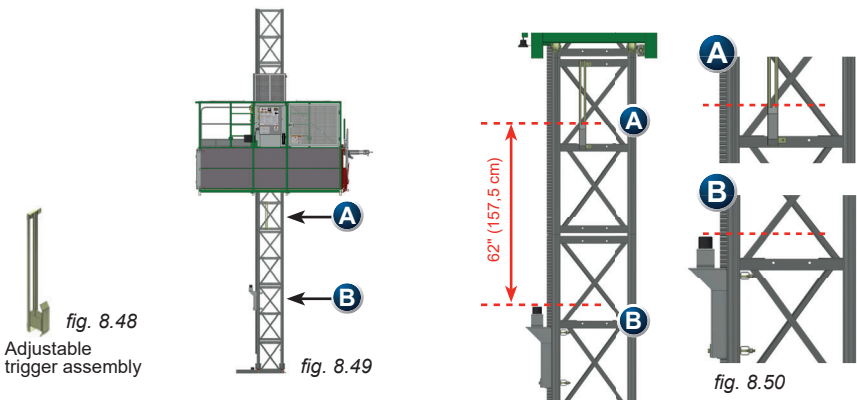

fig. 8.45

- Secure the movable buffer assembly to the mast section using the two support tubes and four 5/8"-11 x 10" GR8 assembly bolts tightened with a torque of 100 lb-ft (136 N-m).

Positioning the adjustable trigger assembly

- Remove the two 3/8" x 1" GR5 bolt assemblies and retrieve the bottom limit and bottom final limit adjustable trigger (fig. 8.48) bolted to the first full mast section.
- Position the adjustable trigger so that it is located 62" (157,5 cm) above the top of the buffers on the movable buffer assembly, as shown in fig. 8.50, ensuring that the bottom final limit sensor stops the motorized unit when it is at least 1" (2,5 cm) above the buffers.



Movable Buffer Assembly
(optional)

Contact with the movable buffer assembly in a powered descent

8- The movable buffer assembly acts as a **final mechanical stop** and, as such, becomes a sacrificial part in the event of a **failure to detect the bottom limit and the bottom final limit** while the unit is **traveling down on motor power**, if the operator cannot stop the unit before it comes into contact with the buffer assembly.

As a result, the top part of the movable buffer assembly will bend under the force generated by the downward motion of the motorized unit.



fig. 8.51

Movable buffer assembly after contact with unit in a powered descent



fig. 8.52

Rubbers and supports must be replaced



fig. 8.53

- 9- The event must be investigated by a **qualified technician** to determine why both the bottom limit and the final bottom limit were not detected properly (failure of a sensor, a switch, etc.).
- 10- The qualified technician must also inspect the mast to detect any damages to the structure or the rack.
- 11- The movable assembly must also be inspected by the qualified technician to identify the parts that must be repaired or replaced before the buffer assembly can be used again. In most cases, the adapter plate and the buffers will have to be replaced completely.

Contact with the movable buffer assembly in a gravity-activated descent (emergency descent)

- 12- During an emergency descent, while the unit is traveling down on gravity, the movable buffer assembly will act as final mechanical stop.



NOTICE

In the event of a failure to detect the bottom final limit and the bottom limit, the movable buffer assembly acts as a final mechanical stop and, in a powered descent, is a sacrificial part. A qualified technician must investigate the event and determine why the bottom limit and the bottom final limit were not detected properly (failure of a sensor, a switch, etc.). The movable buffer assembly must be inspected by a qualified technician to determine if the integrity of the buffer assembly has been compromised by the incident and whether it can be used again or needs to be repaired.

Multiple Mast Handler
(optional)

The use of the multiple mast handler will allow the qualified erector/dismantler to install or remove pre-assembled lengths of mast (also referred to as "sticks") and reduce the time required to complete the assembly of the mast.

General guidelines

- 1- The length of pre-assembled mast allowed must be equal to the authorized height of mast in feet (meters) to reach the height at which to install or remove the next tie level, according to the mast tie schedule specific to the installation.
- 2- For more information about distances between tie levels, refer to the *Mast Tie Schedule* table on p. 70.

Installation of pre-assembled mast sections

- 1- Pre-assemble a length of mast sections on the ground. Mast sections must be laid down horizontally on the ground. For instructions on the assembly of mast sections, refer to p. 65 of the *Mast and Mast Ties* section. Tighten all bolts to 150 lb-ft (203 N-m).

Multiple Mast Handler (optional)

Installation of pre-assembled mast sections

- 2- Install the multiple mast handler on the middle step of the bottom mast section of the pre-assembled length of mast (fig. 8.56).
- 3- It is important to consider the weight of the pre-assembled length of mast that must be lifted and to make sure to select a sling, chain or cable that can lift that weight. For example, a pre-assembled 30' (9,1 m) length (6 mast sections) will weigh 1980 lb (898 kg) if mast sections have one rack, or 2190 lb (993 kg) if mast sections have two racks.
- 4- Insert the sling (or chain or cable) through the pre-assembled length of mast and attach the hook to the shackle on the mast handler.
- 5- Using a crane (or a forklift), carefully lift and lower the pre-assembled length of mast on top of the last mast section installed.
- 6- Still holding the length of mast, attach the bottom mast section to the top of the mast section already installed. For instructions on the assembly of mast sections, refer to p. 65 of the *Mast and Mast Ties* section. Tighten all bolts to 150 lb-ft (203 N-m).

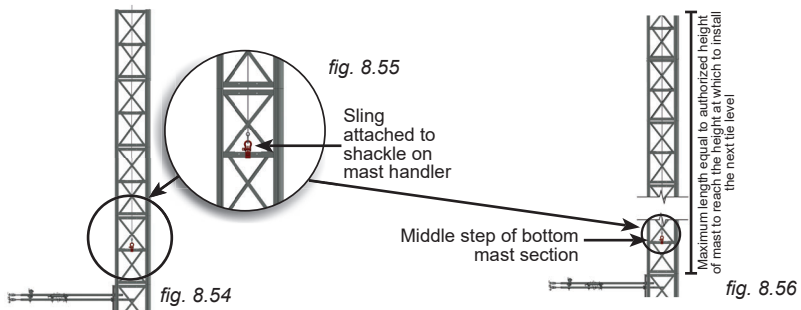

Mast handler shown in red for illustration purposes only

- 7- Remove the shackle from the mast handler to release the hook and sling. Monitor the release of the sling to avoid potential interferences.
- 8- Remove the multiple mast handler from the mast section.
- 9- Raise the motorized unit on the newly added length of mast, making sure that mast bolts are tightened with the proper torque while rising.
- 10- Install the next tie level. For instructions on how to install a tie level, refer to p. 71 of the *Mast and Mast Ties* section.
- 11- Repeat steps 1 to 10 for each pre-assembled length of mast to install, as required and allowed.

Removal of assembled lengths of mast sections

- 1- Bring the motorized unit to where a tie level must be removed. Remove the tie level. For instructions on how to remove a tie level, refer to p. 73 of the *Mast and Mast Ties* section.
- 2- Lower to the next lower tie level.
- 3- Install the multiple mast handler on the middle step of the bottom mast section of the assembled length of mast to remove (fig. 8.56).
- 4- It is important to consider the weight of the assembled length of mast that must be lifted and to make sure to select a sling, chain or cable that can lift that weight. For example, an assembled length of 30' (9,1 m) (6 mast sections) will weigh 1980 lb (898 kg) if mast sections have one rack, or 2190 lb (993 kg) if mast sections have two racks.
- 5- Insert the sling (or chain or cable) through the assembled length of mast and attach the hook to the shackle on the mast handler.
- 6- Remove all bolt assemblies joining the lowest mast section of the assembled length to the mast section below. For instructions on the removal of mast sections, refer to p. 66 of the *Mast and Mast Ties* section.
- 7- Using a crane (or a forklift), carefully lift the assembled length of mast and lower it down in a safe area, away from construction traffic.
- 8- Remove the multiple mast handler from the mast section.
- 9- Repeat steps 1 to 8 for each assembled length of mast to remove, as required and allowed.

Transport and Storage

Preparation of the motorized unit and transport platform car for transport

- 1- Dismantle the motorized unit setup following the dismantling guidelines on p. 26 of the *Transport Platform System* section.
- 2- Bring the unit to base level and loosen the bolt of the bottom limit trigger located on the last (bottom) mast section and lower the trigger all the way down.
- 3- Disconnect the power cable from the motorized unit. **This operation must be carried out by a certified electrician.**
- 4- Using the emergency descent, lower the motorized unit until it rests on the buffers mounted on the base. Make sure there is no load left on the gears or on the output shaft of the gear box.
- 5- Make sure that the material stored inside the transport platform car cannot move or shift during the lift and transport of the car. Make sure the front platform gate is secure.

Lifting and moving of the motorized unit

The lift and relocation of an S Series motorized unit for transport platform with car application must be carried out with extreme care, using proper certified lifting equipment.

It is **mandatory** to refer to and comply with the capacities and limitations of the lifting device as specified by the manufacturer. It is important to consider that an S Series motorized unit for transport platform with car application (without the extensions and the car) that must be lifted has a total weight of 4950 lb (2245 kg).

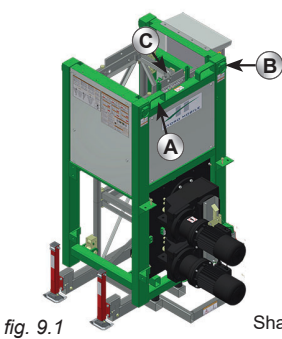

fig. 9.1



fig. 9.2

Two forklift tubes located at the back of the motorized unit

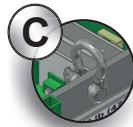

fig. 9.3

Shackle located on rear mast head



fig. 9.5



fig. 9.4

Two D-rings located at the back of the motorized unit



CAUTION

It is **mandatory** to refer to and comply with the capacities and limitations of the lifting device as specified by the manufacturer. It is important to consider that an S Series motorized unit that must be lifted has a total weight of 4950 lb (2245 kg).

Lifting by the forklift tubes

- 1- Prepare the motorized unit as described in the preparation instructions above. Make sure that there is no mast section installed and that all the mast guards are removed.
- 2- Insert the forks in the forklift tubes located at the top of the main frame at the back of the motorized unit ("A" in fig. 9.1).
- 3- Lift and transport the motorized unit over to its destination area.

Lifting by the D-rings

- 1- Prepare the motorized unit as described in the preparation instructions above. Make sure that all the mast guards are removed.
- 2- Slip chains or slings through each of the two D-rings located at the top of the main trolley at the back of the motorized unit ("B" in fig. 9.1). Secure the chains or slings to a crane, a rough terrain forklift or any other appropriate lifting device. If a rough terrain forklift is used, make sure to use an appropriate forklift attachment to secure the chains or slings (shown in red in fig. 9.2).
- 3- Make sure that two workers, wearing proper personal protection (PPE), are standing on the ground using tag lines to help stabilize the structure during the lift, transport and landing of the motorized unit.
- 4- Lift and transport the motorized unit over to its destination area.

Transport and Storage

Lifting and moving of the motorized unit (cont'd)

Lifting by the rear mast head

- 1- Prepare the motorized unit as described in the preparation instructions on p. 88. Make sure that all the mast guards are removed.
- 2- Slip a chain or a sling through the shackle of the rear mast head located at the back of the motorized unit ("C" in fig. 9.1, p. 88). Secure the chain or sling to a crane, a rough terrain forklift of any other appropriate lifting device. If a rough terrain forklift is used, make sure to use an appropriate forklift attachment to secure the chain or sling.
- 3- Make sure that two workers, wearing proper personal protection (PPE), are standing on the ground using tag lines to help stabilize the structure during the lift, transport and landing of the motorized unit.
- 4- Lift and transport the motorized unit over to its destination area.

Lifting and moving of the transport platform car

The lift and relocation of the components of an S Series transport platform with car system must be carried out with extreme care, using proper certified lifting equipment.

It is **mandatory** to refer to and comply with the capacities and limitations of the lifting device as specified by the manufacturer. It is important to consider that the S Series transport platform car (including both extensions, the guardrails and the sliding gate stored inside) to be lifted has a total weight of 4695 lb (2130 kg).

- 1- Prepare the transport platform car as described in the preparation instructions on p. 88.
- 2- Slip chains or slings through the structure of the car, as shown in fig. 9.6, or in the four D-rings located on the sides of the car structure, as shown in fig. 9.9. Secure the chains or slings to a crane, a rough terrain forklift of any other appropriate lifting device. If a rough terrain forklift is used, make sure to use an appropriate forklift attachment to secure the chains or slings (shown in red in fig. 9.6).
- 3- Make sure that two workers, wearing proper personal protection (PPE), are standing on the ground using tag lines to help stabilize the structure during the lift, transport and landing of the transport platform car.
- 4- Lift and transport the transport platform car over to its destination area.

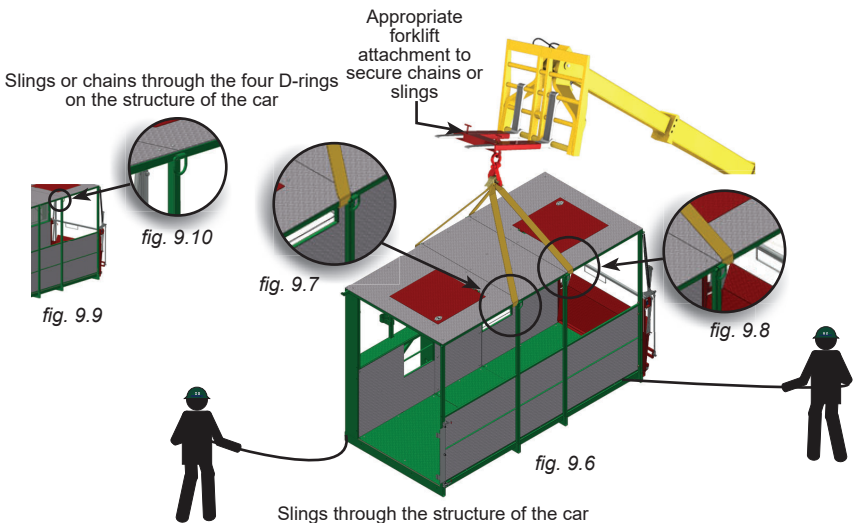

NOTICE

When storing a motorized unit or a transport platform car, there must be sufficient cribbing under the base of the motorized unit and under the car to prevent freezing water from causing damages to the bottom of the structure.

Transport and Storage

Preparation of the motorized unit for storage

- 1- Dismantle the transport platform with car setup following the dismantling guidelines on p. 26 of the *Transport Platform System* section.
- 2- Bring the unit to base level and loosen the bolt of the bottom limit trigger located on the last (bottom) mast section and lower the trigger all the way down.
- 3- Disconnect the power cable from the motorized unit. **This operation must be carried out by a certified electrician.**
- 4- Using the emergency descent, lower the motorized unit until it rests on the buffers mounted on the base. Make sure there is no load left on the gears or on the output shaft of the gear box.

Storage of the transport platform car

- 1- Inspect the structure of the transport platform car, including the inside of open-end tubes, for any sign of damage or distortion. Clean the car and its components thoroughly to limit the effects of any corrosive agent.
- 2- Make sure the front gate is secure.
- 3- The transport platform car must not be stored directly on the ground. Make sure to place sufficient cribbing under the bottom chords to prevent damages to the bottom of the structure.
- 4- Avoid storing the transport platform car in a location with direct exposure to aggressive or corrosive materials in the surroundings.

Storage of the platform extensions

- 1- Before storing them inside the transport platform car, inspect the structure of the platform extensions, including the inside of open-end tubes, for any sign of damage or distortion. Clean the extensions and their components thoroughly to limit the effects of any corrosive agent.
- 2- Store the extensions inside the transport platform car. Make sure they are secured properly.

Storage of the sliding gate and the guardrails

- 1- Before storing them inside the transport platform car, inspect the sliding gate and the guardrails, including the inside of open-end tubes, for any sign of damage or distortion. Clean the guardrails and the sliding gate and its components thoroughly to limit the effects of any corrosive agent.
- 2- Store the sliding gate and the guardrails inside the transport platform car. Make sure they are secured properly.

Storage of the outrigger support

- 1- Before storing it inside the transport platform car, inspect the outrigger support, including the inside of open-end tubes, for any sign of damage or distortion. Clean the support and its components thoroughly to limit the effects of any corrosive agent.
- 2- Store the outrigger support inside the transport platform car. Make sure it is secured properly.

Storage of mast sections

- 1- Inspect the structure of each mast section, including the inside of the open-end tubes, for any sign of damage or distortion. Clean each mast section and its components thoroughly to limit the effects of any corrosive agent.
- 2- Mast sections must be stored on a flat surface away from work areas and construction traffic, vertically or horizontally lying on a side which has no rack.
- 3- Avoid storing mast sections in a location with direct exposure to aggressive or corrosive materials in the surroundings.

Storage of the motorized unit

- 1- Follow all steps in the preparation procedure above.
- 2- Inspect the structure of the motorized unit for any sign of damage or distortion. Clean the motorized unit thoroughly to limit the effects of any corrosive agent.
- 3- Before storing the motorized unit, make sure to place sufficient cribbing under the base to prevent damages to the bottom of the structure.
- 4- Choose an appropriate storage location. Avoid storing the motorized unit in an environment where temperatures fluctuate within the range of 32°F and 104°F (0°C and 40°C) and where relative humidity is in excess of 60%.
- 5- Avoid storing the motorized unit in a location with direct exposure to the sun or UV light and aggressive or corrosive materials in the surroundings.
- 6- When **not in use for an extended period**, the motorized unit must be **moved up and down for 10 minutes every 60 days** to allow the oil to warm up while circulating within the gear case. This will ensure a proper internal lubrication and avoid damages to the internal components and to the oil seals on the output shaft.



Inspections and Maintenance

Proper maintenance and service will warrant safe, economical, and dependable operation of an S Series transport platform with car system. In order to ensure operational safety and avoid failures, the owner must make sure that all the scheduled inspection and maintenance operations have been effectively and timely carried out according to the inspection and maintenance schedules recommended for S Series motorized units and their accessories.

Blank copies of the daily inspection checklist must be available on job sites at all times to be filled out when daily and weekly inspection operations are carried out. Maintenance and inspection logs must be kept on record for warranty and safety purposes.

Copies of all maintenance and inspection checklists can be obtained by contacting the distributor/service center or the Hydro Mobile technical support team or downloaded directly from the Hydro Mobile website at www.hydro-mobile.com.

Daily and Weekly Inspections and Maintenance

Each Hydro Mobile motorized unit and its accessories must be submitted to daily (or before every working shift) and weekly inspections and maintenance operations performed by the qualified user/operator. For more information about qualified operators, refer to p. 7 of the *Performance and Safety Rules* section.

Daily and weekly inspection operations are only necessary when the transport platform and the motorized unit are in use. The owner and/or user is responsible for all inspection and maintenance operations. Before being first used on a job site, an S Series motorized unit and transport platform components must be inspected effectively and timely, according to the schedules recommended for S Series motorized units and their accessories.

Maintenance and inspection logs must be kept on record for warranty and safety purposes. Blank copies of the daily inspection checklist must be available on job sites at all times to be filled out when daily and weekly inspection operations are carried out. The notes and comments form must be used to indicate any discrepancy or any item found to be not acceptable. Any discrepancy must be reported to the owner/user and the competent person. Appropriate corrective action must be taken immediately before the motorized unit can be used again. Corrective actions must be performed by qualified personnel.

Greasing of gears and rack(s)

A proper and timely greasing of the gears and the rack is critical to guarantee performance and longevity of the Hydro Mobile S Series mast climber system. It is important to understand that not all open gear greases and lubricants offer equal levels of quality and performance. Consequently, only open gear grease approved by the Hydro Mobile Engineering department must be used on Hydro Mobile equipment.

Application frequency must be based on the installation and the cumulative runtime use of the equipment. However, the gears and racks must typically be greased after every **8 to 10 hours of operation** (with unit traveling up and down the mast).

Gears and racks on a typical mast climber with a duty cycle of 25% will require to be greased on a weekly basis.

$$8 \text{ hrs/day} * 5 \text{ days} * 25\% \text{ duty cycle} = 10 \text{ hrs}$$

Higher duty cycle operation will require greasing to be more frequent. For example, use of the S Series unit in a transport platform application in 100% duty cycle will **increase greasing requirements** to up to once a day. Grease must be applied to the gears and to the rack(s) **at the end of the working shift**. If an **aerosol open gear lubricant** is used, **grease must be allowed to stand for 2-3 hours** before the motorized unit is used again. Use an open gear lubricant recommended by Hydro Mobile.

Applying grease to the rack(s)

- 1- Make sure that the motorized unit is at the top of the work.
- 2- Loosen the bolts holding the rear mast guard in place (fig. 9.12, p. 92).
- 3- Lift the mast guard to remove it (fig. 9.13, p. 92) and store it properly.



NOTICE

It is critical to inspect, clean and grease the gears and rack(s) of a Hydro Mobile S Series transport platform system following the recommended inspection schedules. Failure to clean and grease the gears and rack(s) properly and in a timely fashion can lead to equipment damage and premature wear of the gears, the racks and pinions and cause down time.

Inspections and Maintenance
Greasing of gears and rack(s)

Applying grease to the rack(s) (cont'd)



fig. 9.11

Loosen the two bolts holding the rear mast guard in place

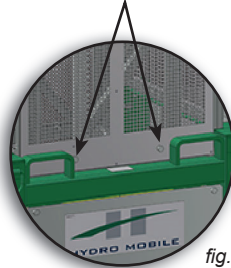
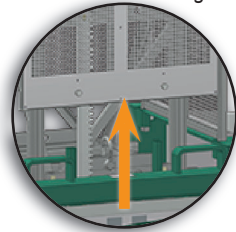

fig. 9.12



Lift and remove the mast guard

fig. 9.13

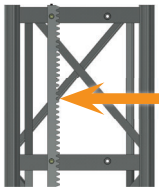

fig. 9.14

Apply grease directly on the rack teeth

- 4- Apply grease directly on the rack teeth, from the top of the mast down to base level, making sure to avoid grease splatters on other components. It is important to use an open gear lubricant recommended by Hydro Mobile (fig. 9.15).
- 5- Once the grease has been applied on the whole length of the mast, reinstall the mast guard and tighten both bolts to secure it in place.
- 6- If an **aerosol open gear lubricant** is used, **grease must be allowed to stand 2-3 hours** before the motorized unit is used again.
- 7- Inspect the rack after each working shift and apply grease, as needed.

Recommended open gear lubricants	
Manufacturer	Part number
Prolab	OG-700
Petron Corporation	Gear Shield NC

fig. 9.15

Applying grease to the gears

- 8- Make sure the motorized unit is at base level. Gears can be accessed by the front of the motorized unit, as shown in fig. 9.16.

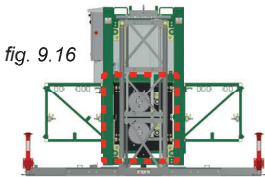

fig. 9.16

Location of gears on the front of the unit

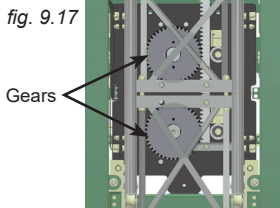

fig. 9.17

Gears

Apply grease on both gears

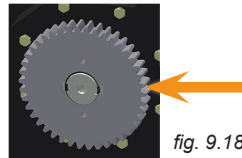

fig. 9.18

Apply grease directly on the gear teeth

Inspections and Maintenance

Greasing of gears and rack(s)

Applying grease to the gears (cont'd)

- 9- Inspect each gear and clean any **old grease** expelled out of the gear meshing. Old grease must be **cleaned off** on a regular basis.
- 10- Apply grease directly on the teeth of each gear (fig. 9.18, p. 92), making sure to avoid splatters on other components. It is important to use an open gear lubricant recommended by Hydro Mobile (fig. 9.15, p. 92)

Frequent Inspections and Maintenance

Frequent inspections must be performed by a qualified technician. For more information about qualified technicians, refer to p. 7 of the *Performance and Safety Rules* section.

Each Hydro Mobile motorized unit and its accessories must be submitted to a frequent inspection performed every three months by a qualified technician.

Maintenance and inspection logs must be kept on record for warranty and safety purposes. Blank copies of the frequent inspection checklist must be filled out when frequent inspection operations are carried out. The notes and comments form must be used to indicate any discrepancy or any item found to be not acceptable. Any discrepancy must be reported to the owner/user and the competent person. Appropriate corrective action must be taken immediately before the motorized unit can be used again. Corrective actions must be performed by a qualified technician.

All inspection and maintenance steps included in the daily inspection checklist must be performed before the frequent inspection and maintenance steps.

It is recommended to use replacement parts manufactured by or recommended by Hydro Mobile. The use of substitute parts could not only void the warranty covering this motorized unit and its components but cause serious damages that could lead to injury or death. It is recommended to replenish and grease components only with fluids and lubricants recommended by Hydro Mobile.

Annual Inspections and Maintenance

Annual inspections must be performed by a qualified technician. For more information about qualified technicians, refer to p. 7 of the *Performance and Safety Rules* section.

Each Hydro Mobile motorized unit and its accessories must be submitted to an annual inspection performed by a qualified technician. This annual inspection must be carried out no later than 13 months after the previous annual inspection.

Maintenance and inspection logs must be kept on record for warranty and safety purposes. Blank copies of the annual inspection checklist must be filled out when annual inspection operations are carried out. The notes and comments form must be used to indicate any discrepancy or any item found to be not acceptable. Any discrepancy must be reported to the owner/user and the competent person. Appropriate corrective action must be taken immediately before the motorized unit can be used again. Corrective actions must be performed by a qualified technician.

It is recommended to use replacement parts manufactured by or recommended by Hydro Mobile. The use of substitute parts could not only void the warranty covering this motorized unit and its components but cause serious damages that could lead to injury or death. It is recommended to replenish and grease components only with fluids and lubricants recommended by Hydro Mobile.



WARNING

Any equipment, accessory or component found to be non compliant with inspection requirements must not be used before it has been duly inspected and deemed compliant. Any discrepancy must be reported to the owner, the user and the competent person. Appropriate corrective action must be taken immediately before the motorized unit can be used again. Corrective actions must be performed by a qualified technician.

Inspections and Maintenance

Copies of inspection and maintenance checklists shown below can be obtained by contacting the distributor/service center or the Hydro Mobile technical support team or downloaded directly from the Hydro Mobile website at www.hydro-mobile.com.

Daily inspection checklist

The form is titled 'DAILY INSPECTION CHECKLIST' and includes a warning icon. It contains a header section for project information, a 'Pre-Start Inspection' section with a checklist of items, and a large table for recording inspection results with columns for 'Inspected', 'Status', and 'Remarks'.

fig. 9.19

Frequent inspection checklist

The form is titled 'FREQUENT INSPECTION CHECKLIST' and contains a header section for project information, a 'Pre-Start Inspection' section with a checklist, and a table for recording inspection results with columns for 'Inspected', 'Status', and 'Remarks'.

fig. 9.20

Annual inspection checklist

The form is titled 'ANNUAL INSPECTION CHECKLIST' and contains a header section for project information, a 'Pre-Start Inspection' section with a checklist, and a table for recording inspection results with columns for 'Inspected', 'Status', and 'Remarks'.

fig. 9.21

Copies of the job survey checklist and the handover checklist shown below can be obtained by contacting the distributor/service center or the Hydro Mobile technical support team or downloaded directly from the Hydro Mobile website at www.hydro-mobile.com.

The form is titled 'JOB SURVEY - JOB HAZARD ANALYSIS' and includes a header section for project information, a 'Job Description' section, a 'Hazard Analysis' section with a table for identifying hazards, and a 'Safety Measures' section with a checklist.

fig. 9.22

The form is titled 'INSTALLATION HANDOVER SHEET' and includes a header section for project information, a 'Handover Information' section with a table for recording handover details, and a 'Remarks' section.

fig. 9.23