

Owner's Manual



ELEVATING
EFFICIENCY

Call us for information:
1-888-484-9376 (US)
(toll free in the United States)
450 589-8100 (Canada)



11053005-0-00000-0

M2_OpMan_v5.05_EN

© 2024 by Hydro Mobile, a division of BrandSafway Access, Inc. All rights reserved
 This manual was produced by Hydro Mobile on Adobe® InDesign CS5.5® version 5.0.1 for Windows®.
 Technical drawings were prepared using Autodesk Inventor® 2012. Illustrations were created with Autodesk® 3ds Max®, Autodesk Inventor® 2008, Adobe® Illustrator CS5.1 for Windows® and Adobe® Photoshop CS5.1® for Windows®.

This manual may not, in whole or in part, be copied, photocopied, reproduced, translated, or converted to any electronic or machine readable form without prior written consent of Hydro Mobile.

APAVE certification: 0077-5237-760-0411-4103 (2014)

NOTE

All assembly and operation instructions located on motorized units and bridges take precedence over information contained in this manual. Should there be any discrepancies discovered throughout any published documentation issued by Hydro Mobile or its authorized affiliates, the following order of precedence shall prevail:

1. **Written documents issued by the Hydro Mobile Engineering department**
2. **Recall instructions**
3. **Assembly or operation instructions displayed on the motorized unit**
4. **Owner's manual**

Any use of one or several Hydro Mobile motorized units, with or without accessories, in such a configuration or manner as not explicitly described in this manual is not allowed without the permission of Hydro Mobile Inc.

REVISION LIST

Version	Date	Description
v1.0	April 2002	First edition of Owner's manual
v2.0	May 2002	Addition of forward extension and monorail
v2.1	June 2002	"Long" mast ties changed for "extensions"
v2.2	Sept 2002	Access and rest platforms
v3.0	Sept 2004	Addition of 14' (4,3 m) unit, split base and training sheets
v3.1	Sept 2004	Modifications to weights; various typographical corrections; modification of grease type
v4.0	Sept 2010	Overall revision; inclusion of additional accessories; detailed warranty policy; inclusion of new modular bridge assemblies
v4.01	Oct 2010	Minor corrections
v4.02	Nov 2010	Modifications to load capacity charts; minor additions and corrections
v4.03	Oct 2015	Corrections to components included with shipped unit
v5.0	Feb/Mar 2016	Overall revision; major changes to installation instructions: inclusion of accessories (sidewalk canopy, mast base plates, swivel bridge, flush bearing bridge adapter, multiple mast handler) (typo corrections in March before first print)
v5.01	Sept 2016	Modification to distance to wall in MU dimensions; modification of number of plywoods required when cribbing; modifications to bridge lengths in load capacities
v5.02	April 2017	Minor corrections; addition of storage instructions for unit and bridge
v5.03	March 2024	Changes to credits and introduction pages
v5.04	May 2024	Correction of typographical error in the serial number before which multi purpose insert bridges requiring optional reinforcing kit when used in bearing configurations.
v5.05	November 2024	Correction of leftover typographical error for MPI bridges serial numbers.

LEGEND OF ICONS

These icons are used to highlight important information throughout this manual



Information

Useful information for safe and easy operation



Warning note

An important warning: damage or injury may occur



Useful tip

A useful tip to facilitate installation or operation



Wind speed warning

An important warning: wind speed conditions must be observed to avoid damage or injury



Type of setup

Single unit freestanding installation



Type of setup

Single unit installation with mast ties



Type of setup

Multiple units freestanding installation



Type of setup

Multiple units installation with mast ties

The information and instructions contained in this manual applies to units bearing the following serial numbers

24M 5157 M2 and up

14M 0200 M2 and up

GENERAL INFORMATION

Model	M2 Series 14' (4,3 m) motorized unit	<input type="checkbox"/>
	M2 Series 24' (7,3 m) motorized unit	<input type="checkbox"/>
Motorized unit serial number	_____	
Manufacturing date	_____	



HYDRO MOBILE
www.hydro-mobile.com

125 de l'Industrie
 L'Assomption, Quebec, Canada
 J5W 2T9

For orders or information:
 1-888-484-9376 (US)
 (toll free in the United States)
 450 589-8100 (Canada)

TABLE OF CONTENTS

General Information

Introduction 3
 Warranty 4

Performance and Safety

Performance and safety rules 5
 Definition of the competent person 5
 Definition of the qualified person 5
 General guidelines 5
 Definition of standard installation 7

1 – Motorized Unit

Overview 8
 List of components included with shipped unit 8
 Specifications 10
 Weight of components 12
 Dimensions 13
 Positioning
 Minimum bearing surface capacities 15
 Cribbing 16
 Setup and configurations
 General guidelines 17
 Combination of standard and non standard configurations 17
 Definition of a standard configuration 17
 Positioning of base outriggers 19
 Installation of freestanding setups
 Single unit 19
 Multiple units 21
 Installation of tied setups
 Methods to install tie levels 22
 “A” – progressive installation
 Single unit 23
 Multiple units 24
 “B” – pre-installation of tie levels
 Single unit 25
 Multiple units 27
 “C” – pre-installation of tie levels
 Single unit 28
 Multiple units 30
 Dismantling an installation
 Safety guidelines 32
 Freestanding installations
 Single unit 32
 Multiple units 32
 Tied installations
 Single unit (“A” or “B” installation) 33
 Multiple units (“A” or “B” installation) 34
 Single unit (“C” installation) 35
 Multiple units (“C” installation) 36
 Lifting and moving a motorized unit setup 37

2 – Safety Devices

Safety hooks system 41
 Fall protection equipment 41

3 – Bridges

Standard bridge
 Overview 43
 Bridge types 43
 Cantilever bridge
 Installation 43
 Bearing bridge
 Safety guidelines 46
 Installation 46
 Offset bearing bridge structure 47
 Safety chains 47
 Dismantling a bearing bridge 48
 Multi purpose insert bridge (MPI)
 Forward/Back extension bridge 49
 Cantilever bridge 50
 Lateral cantilever bridge 50
 Narrow bearing bridge 51
 Alternate bridge configurations 53
 Angled bearing bridge setup 53
 Inside / Outside corner bearing bridge 54
 Swivel bridge
 Installation of the square bridge adapter 56
 Installation of the swivel and square bridges 57
 Angle adjustment 57
 Standard and swivel bridge guardrails 58
 Front cantilever configurations 59
 Counterweight adapter 60

4 – Power Pack and Operating Components

Motorized unit preparation instructions 62
 Engine startup preparation instructions 63
 Storage of the control post 64
 Raising the platform 65
 Lowering the platform 67

5 – Masts and Mast Ties

Installation of a mast section 69
 Installation of mast ties 70
 Mast tie schedule 70
 Appropriate mast tie installation 71
 Mast tie requirements for
 planking configurations 72
 Angle of mast ties and wall tie distances 74
 Passing mast tie levels 75
 Removal of mast ties 75
 Removal and transport of mast sections 75
 Angled mast ties 76
 Installation of the angle bracket 76
 Installation of extended mast ties 77
 Anchoring system
 Wall tie types 78
 Installation of floor ties 79
 Installation of fixed wall ties 79
 Installation of a welded wall tie on a beam 79
 Installation of a re-usable wall tie 79

6 – Load Capacities

Changes to the calculation method 80
 Load capacity calculation guidelines 80
 Evenly distributed – Single unit setup
 14’ (4.3 m) motorized unit 81
 24’ (7.3 m) motorized unit 81
 Evenly distributed – Multiple units setup
 14’ (4.3 m) motorized unit 82
 24’ (7.3 m) motorized unit 83
 MPI – Evenly distributed with 24’ (7.3 m) unit
 Lateral cantilever 84
 Forward extension 85
 Narrow bearing bridge 86
 Swivel bridge with 24’ (7.3 m) unit
 Single unit front 0-45 degrees 87
 Single unit with counterweight adapter 88
 Angled and corner installations
 Inside corner 89
 Outside corner 89

7 – Accessories

Safety accessories
 Guardrails
 Standard 91
 Face guardrail supports 91
 Plank-end guardrails 92
 Movable guardrails 93
 Universal plank safety support 93
 Retractable rest platform 94
 Other accessories
 Outriggers
 Planking configuration guidelines 95
 Outrigger selection table 95
 Doubled outriggers 96
 Cross boxes 97
 Non standard planking configurations 97
 Top outriggers 99
 Bottom outriggers 99
 Cantilever outrigger supports 100
 Sliding doors 100
 Wheel set 102
 Hoist 103
 Weather protection 104
 Monorail 108
 Flush bearing bridge adapter 110
 Securing the access walkway 111
 Adapter base for sidewalk canopy installation 112
 Mast base plates 115
 Multiple mast handler 117

8 – Transport, Storage and Maintenance

Transport and storage
 Preparation of the motorized unit for transport 118
 Storage of the control post 119
 Storage of the motorized unit 119
 Inspections and maintenance
 Daily and weekly inspections and maintenance
 Inspection and maintenance of the cylinder hook 120
 Greasing the mast carriage and guide rollers 121
 Inspecting and greasing the safety hooks 122
 Frequent inspections and maintenance 123
 Annual inspections and maintenance 123
 Examples of checklists 124
 Hydraulic diagram 125

Introduction

Dear owner or user:

Thank you for investing in a Hydro Mobile M2 Series mast climbing work platform system (24' / 7,3 m model or 14' / 4,3 m model). The design of these motorized units reflects over a decade of continued field operation, testing and research work and comes as a solution to our company's deepest concern, your safety and well being on the job.

To ensure that the workplace becomes safer and more efficient using a Hydro Mobile system, always have appropriately trained personnel assemble, operate, dismantle and move your mast climbing work platform system. These qualified persons will be required to read this owner's manual and assimilate the information contained herein. Failure to do so could lead to serious injury and/or equipment damage.

These motorized units were designed in accordance with the following standards: US ANSI A92.9-2011, ISO 16369:2007 and EN 1495, 2006/42/CE "directive machine" and 89/336/CEE "directive CEM". Furthermore, these motorized units and the owner's manual comply with US ANSI A92.9-2011 standards, Federal Occupational Safety and Health Administration Standards OSHA 29CFR1926 subpart L; with ISO 16369:2007 and CSA B354.5-07; and with EN 1495, 2006/42/CE "directive machine", 89/336/CEE "directive CEM" and ISO 16369:2007.

To maximize the life expectancy of your equipment and to enjoy years of trouble free operation, we recommend that this Hydro Mobile system be serviced according to maintenance schedules and recommendations provided in this manual. It is also advised to refer to the Honda user's manual included with the motorized unit.

Should you have any questions or concerns, please contact the nearest authorized service center or Hydro Mobile directly at 888-484-9376 (in the United States) or 450 589-8100 (in Canada). You can also visit our Web site at www.hydro-mobile.com for additional support and information on our factory safety and performance training seminars.

We wish you years and years of safe, productive construction and renovation work.

Warranty

Warranty period

Hydro Mobile Inc., herein referred to as Hydro Mobile, warrants its new M2 Series motorized units to be free from defect of materials and workmanship for a period of 15 months from the date of delivery to the authorized distributor/service center.

Hydro Mobile also warrants its new M2 Series parts and accessories to be free from defect of materials and workmanship for a period of 15 months from the date of delivery to the authorized distributor/service center.

Product registration

In accordance with standards governing mast climbing work platform systems, the owner of a Hydro Mobile M2 Series unit **must register the product with Hydro Mobile within sixty (60) days**. The initial buyer of a Hydro Mobile M2 Series unit is automatically registered by Hydro Mobile.

Hydro Mobile must be kept informed of any change of ownership. The new owner must provide Hydro Mobile with a full name and address, along with the model and serial number of the unit acquired.

Description of warranty

Parts and accessories manufactured by Hydro Mobile

Hydro Mobile's obligation and liability under this warranty are expressly limited to repairing or replacing with re-manufactured or new parts, at Hydro Mobile's option, any part and accessory manufactured by Hydro Mobile proven defective after inspection by Hydro Mobile which appear to have been defective in material or workmanship. Only permanent repairs will be covered under this warranty. Hydro Mobile reserves the right to ask for maintenance records of the defective part before settling a claim and to deny such claim if maintenance records are not available or not compliant with maintenance schedules.

This warranty shall not apply to component parts or accessories of products not manufactured by Hydro Mobile and which carry the warranty of the manufacturer thereof or to normal maintenance (such as engine tune-up) or any part necessary to perform such maintenance. Hydro Mobile offers no other warranty, expressed or implied, and offers no warranty of merchantability or fitness for any particular purpose.

Engine

All engines manufactured by Honda under the "GX" lineup are covered by an international warranty of 36 months (12 months on mufflers). To have an engine repaired under this warranty, the engine must be brought to an authorized Hydro Mobile distributor/service center or to a Honda authorized distributor/service center.

Battery

All the batteries shipped from the factory with new equipment are guaranteed for a period of 60 days. Any battery discharged due to operator error will not be covered under this warranty. Dead batteries that can be recharged will not be replaced under this warranty.

Costs and liability associated with warranty

Hydro Mobile's obligation under such warranty shall not include duty, taxes or any other charge whatsoever, or any liability for direct, indirect, incidental or consequential damage or delay.

Exclusion

Any use of one or several Hydro Mobile motorized units, with or without accessories, in such a configuration or manner as not explicitly described in the owner's manual is not recommended without the prior written permission of Hydro Mobile.

Any improper use, including operation after discovery of defective or worn parts, shall void this warranty. Improper use also includes operation beyond rated capacity, substitution of parts other than those approved by Hydro Mobile, including anchor systems, or any alteration, modification or repair by others in such manner as in Hydro Mobile's judgment affects the product materially and adversely.

Labor

All warranty work must be performed by a certified Hydro Mobile technician to be eligible for reimbursement under the warranty.

Performance and Safety Rules

SAFETY comes first. The installation and operation of a mast climber is subject to hazards that can be avoided only by using extreme care and common sense, and by providing the **appropriate training and supervision** to all its users.

It is essential that the **installation and dismantling** of an M2 Series motorized unit and its related accessories be carried out according to the guidelines, instructions and warnings included in the owner's manual and performed by **qualified erectors/dismantlers** under the supervision of a **competent person** (see boxes below).

It is also imperative that the **operation** of an M2 Series motorized unit setup be carried out according to the guidelines, instructions and warnings included in the owner's manual. To ensure safe and proper operation, Hydro Mobile recommends that **two persons** be on hand to perform maneuvers for **each motorized unit in a setup** and that **at least one of those two persons is a qualified operator** (see box below) for an M2 Series motorized unit and its accessories.

WARNING



The configurations and methods to achieve these configurations for an M2 Series installation shown and described in this owner's manual are the only ones authorized by Hydro Mobile. For any configuration or method to achieve such a configuration other than those shown and described in this owner's manual, contact the Hydro Mobile technical support team.

WARNING



It is **mandatory** to refer to the *Mast Tie Schedule* table on p. 70 of the *Masts and Mast Ties* section **before the installation** of any M2 Series configuration.

Definition of the competent person

Competent person means a person who is capable of identifying existing and predictable hazards in the surroundings or working conditions which are unsanitary, hazardous or dangerous to employees, and who has authorization to take prompt corrective measures to eliminate them.

Definition of the qualified person

"**Qualified**" means a person who, by possession of a recognized degree, certificate or professional standing, or who by extensive knowledge, training and experience, has successfully demonstrated the ability to solve or resolve problems relating to the subject matter, the work or the project.

Only a **qualified person** on the specific make and model of the Hydro Mobile equipment can carry out the following tasks:

User/operator

A **qualified user/operator** is allowed to operate Hydro Mobile units according to the guidelines, instructions, warnings and methods set out in the owner's manuals and Hydro Mobile training courses and after they have been erected, tested and passed for use by a qualified person.

Erector/dismantler

A **qualified erector/dismantler** is allowed to erect, dismantle, test, pass for use and modify the configuration of Hydro Mobile units according to the guidelines, instructions, warnings and methods set out in the owner's manuals and Hydro Mobile training courses.

Technician

A **qualified technician** is allowed to perform maintenance inspections and repairs on Hydro Mobile units according to the guidelines, instructions, warnings and methods set out in the owner's manuals and Hydro Mobile training courses.

Hydro Mobile recommends that Qualified Persons follow the Hydro Mobile University Training Program on the specific task and specific make and model to get proper qualifications. For more information on the Hydro Mobile University Training Program, visit www.hydro-mobile.com/training.

General guidelines

- 1- Prepare a layout plan showing how the mast climbing work platform system (motorized units, bridges and accessories) will be positioned near structures or walls to be erected. On long walls, install separate mast climber sections to allow for flexibility. Make sure to position motorized units so as to provide proper anchoring points for masts for tied installations.
- 2- Rely on a licensed engineer for help on special jobs and to approve plans if required by local regulation.
- 3- It is recommended to use the job survey form as a guide for the proper installation of the configuration. Refer to p. 124 of the *Transport, Storage and Maintenance* section for more information about the job survey form.

Performance and Safety Rules

General guidelines (cont'd)

- 4- Any M2 Series setup requiring an approved, angled or non-linear configuration achieved with a forward/back extension or a swivel bridge **must have mast ties**. In addition, **mast ties must be installed following the appropriate schedule for the installation of tie levels**.
- 5- Any M2 Series setup requiring the use of additional, approved accessories and equipment such as a hoist and hoist support structure specifically manufactured to be used on an M2 Series installation, weather protection or an approved planking configuration wider than the standard four planks **must have mast ties**. In addition, **mast ties must be installed following the appropriate schedule for the installation of tie levels**.
- 6- It is **mandatory** to refer to the *Mast Tie Schedule* table on p. 70 of the *Masts and Mast Ties* section and to the *Load Capacities* section on p. 80 **before the installation of any M2 Series configuration**.
- 7- Establish the distance between the mast climbing work platform system and the structure or wall, taking into account the length of plank outriggers, as well as curvatures, balconies, columns, trees, telephone wires, electrical lines, etc.
- 8- Refer to and follow local regulations governing distances between the mast climbing work platform system and electrical lines. As a reference, North American regulations generally recommend keeping a safe distance of at least 10' (3 m) from overhead power lines carrying 50,000 volts or less.
- 9- Make sure the ground or support surface capacity meets with values included in the *Minimum Bearing Surface Capacities* table herein (fig. 1.18, p. 15). Soil compacting, cribbing or shoring can increase bearing capacity.
- 10- Never modify the mast climbing work platform system or use substitute factory parts. This could adversely affect worker safety, unit performance and void the warranty. In addition, this could lead to serious injury or death.
- 11- The M2 Series motorized unit **must not be used** with any equipment or any accessories not specifically manufactured and rated by Hydro Mobile to be used with M2 Series motorized units. For the use and installation of any such equipment or accessories, contact the distributor/service center or the Hydro Mobile technical support team.
- 12- Never use the motorized unit in a enclosed space due to carbon monoxide emissions or in a place where explosives are stored. It is recommended to use an electrically-powered motorized unit as an alternative.
- 13- Each M2 Series motorized unit must be equipped with an appropriate fire extinguisher (not supplied). Use the bracket supplied with the motorized unit to hang the fire extinguisher in a readily accessible location (fig. 1.1, p. 8).
- 14- It is recommended not to smoke on the platform.
- 15- Planks used for planking must be scaffold graded (SPF), in good condition and meet local regulations.
- 16- **IMPORTANT:** It is strongly recommended not to use equipment that may generate excessive vibrations or reactions on Hydro Mobile platforms.
- 17- Workers exposed to potential hazards must always wear proper personal protection equipment (PPE) such as a helmet, safety boots, a fall arrest harness, etc., as prescribed by local regulations. In all cases where workers are exposed to fall hazards, fall protection is required. Installation of all the necessary guardrails is **mandatory**.
- 18- The M2 Series motorized unit must only be used on a mast whose height does not exceed 250' (76 m).
- 19- To ensure work efficiency, maintain an adequate equipment and parts inventory on the job site. Keep equipment in good condition.
- 20- Inspection and maintenance operations must be carried out efficiently and in a timely manner. Daily inspections and their related operations must be performed by a **qualified user/operator** every day or before every working shift. Frequent and annual inspections and their related operations must be carried out by a **qualified technician**. Refer to the *Transport, Storage and Maintenance* section on p. 120 for more information on inspection and maintenance requirements for M2 Series motorized units and their accessories.
- 21- After installation, mark off limit areas of the system using fencing, barriers, warning tape and note emergency phone numbers (fire and police dept.) for quick reference. **Prepare an emergency evacuation plan that is specific to the job site and is in accordance with local regulations**.
- 22- **Never load bridges or motorized units beyond their rated capacities**. Overloading may bring damages to equipment or cause the installation to become unbalanced, leading to serious injury or death.

Performance and Safety Rules

General guidelines (cont'd)

- 23- Contact the distributor/service center or Hydro Mobile for service, repair or technical advice. Refer to equipment type and serial number when calling.
- 24- Each person should access the platform by a staircase, through an opening in the building or, when the unit is at least 10' (3 m) above base level, by the **back** of the mast, using the access walkway to reach the platform. The use of the access walkway is **mandatory** to reach the platform by the mast. To avoid crushing hazards, it is important to make sure that the access ladder is **fully extended** before it is used. In all cases, transfer must be safe and free from obstruction.
- 25- The use of appropriate fall protection equipment is **mandatory** when using the mast for climbing or descending at heights between 30' (9,1 m) and 69' (21 m), when modifying plank configuration or whenever the worker is exposed to a fall hazard. Failure to use fall protection equipment can expose the user to serious injury or death. It is not recommended to climb up the mast to reach work areas at heights over 69' (21 m) because of the time and effort required to reach such heights. The use of alternate equipment compliant with local regulations, such as a rapid mast climber, a transport platform system, or a conventional scaffold stair system will prove to be more efficient. Refer to local regulations for more information.
- 26- Only one person at a time may evacuate the platform by climbing down the mast. It is not recommended to evacuate the platform by climbing down the mast when the platform is at heights beyond 69' (21 m).
- 27- In the event of an abnormal occurrence or operation which could compromise security (ex. malfunction of a motorized unit component, collision with an obstacle, etc.), immobilize the unit and inform the competent person.
- 28- It is strongly recommended not to touch any of the moving parts on the motorized unit when it is in use.
- 29- All access doors and panels on the motorized unit must be closed when they are not in use. All access doors and panels should be free from any material or obstruction.
- 30- The motorized unit must not be used or operated during an electrical thunderstorm.
- 31- The deposit of loads on the setup must be done with extreme care and under proper supervision. Refer to the *Load Capacities* section on p. 80 for more information about placing loads on the platform. When the motorized unit setup is not in use and **above base level**, loads must not be left on the platform except for counterweights.



WARNING - WIND SPEEDS

The **erection** and **dismantling** of a motorized unit setup (including the base, the bridges, the masts, the mast ties and all the other components) must not be conducted when wind speeds exceed **28 mph (45 km/h)**. **Freestanding installations** and **setups equipped with weather protection**, when allowed, must not be used with wind speeds exceeding **28 mph (45 km/h)**. **Weather protection**, when allowed, **must not be used** when work is performed on an **open air structure**. A motorized unit setup with **mast ties must not be operated** when wind speeds exceed **35 mph (56 km/h)**.

When a motorized unit is not in use

- It is mandatory to leave the platform between two tie levels when the motorized unit is not in use.
- Remove all loads from the setup when the motorized unit is not in use.
- It is mandatory to leave all the counterweights applied on the setup in place when the motorized unit is not in use.
- In a freestanding installation, when allowed, the motorized unit must be brought down to base level when not in use.
- If wind speeds are expected to exceed **94 mph (150 km/h)**, the motorized unit must be brought down to base level when not in use.

Definition of a standard installation

A **standard installation**, referred to throughout this owner's manual and related documentation, is an installation that **does not require** the use of additional equipment, such as a forward extension bridge, a swivel bridge or a planking configuration wider than four planks nor the use of accessories such as weather protection, a hoist or a monorail.

It is **mandatory** to refer to the *Load Capacities* section on p. 80 for the number of bridges allowed in a standard single unit or multiple units installation.

Motorized Unit Overview
24' (7,3 m) motorized unit

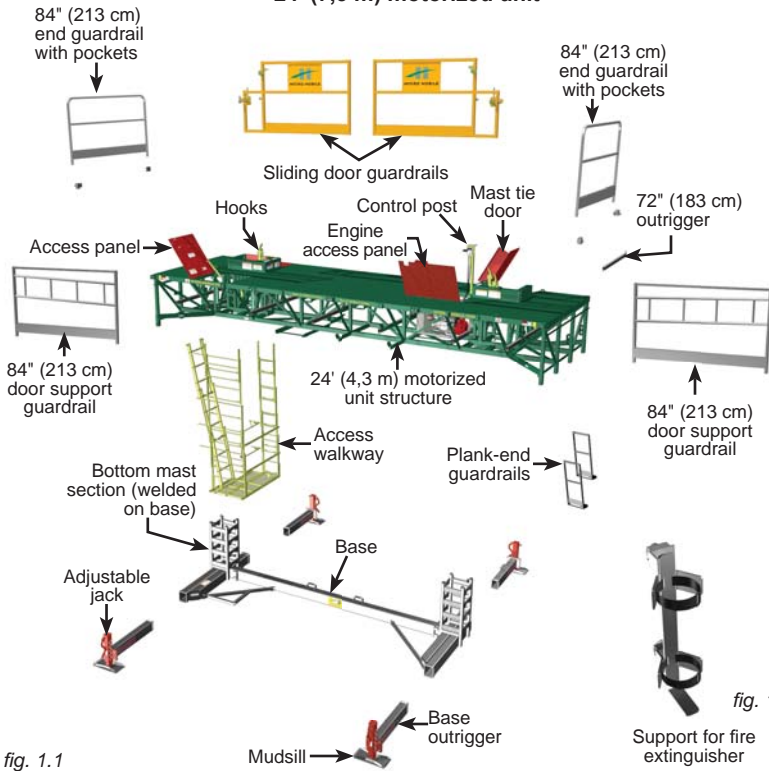

fig. 1.1

fig. 1.2
 Support for fire extinguisher

Note: Items depicted in illustrations may differ from actual products.

fig. 1.3

List of components included with shipped unit			
M2 SERIES 24' (7,3 m) MOTORIZED UNIT			
Qty	Component	Qty	Component
1	M2 Series 24' (7,3 m) motorized unit	1	1 1/2" wrench
1	15/16" wrench	2	84" (213 cm) end guardrails
2	sliding guardrail doors	4	pockets for 84" (213 cm) end guardrails
2	84" (213 cm) guardrail doors	6	72" (183 cm) outriggers
2	plank-end guardrails	1	Owner's manual
1	support for fire extinguisher		
M2 SERIES 14' (4,3 m) MOTORIZED UNIT			
Qty	Component	Qty	Component
1	M2 Series 14' (4,3 m) motorized unit	1	1 1/2" wrench
1	15/16" wrench	2	84" (213 cm) end guardrails
2	sliding guardrail doors	4	pockets for 84" (213 cm) end guardrails
2	44" (112 cm) guardrail doors	4	72" (183 cm) outriggers
2	plank-end guardrails	1	Owner's manual
1	support for fire extinguisher		
Note The list of components included with each shipped motorized unit may change without notice.			

Motorized Unit Overview

14' (4,3 m) motorized unit

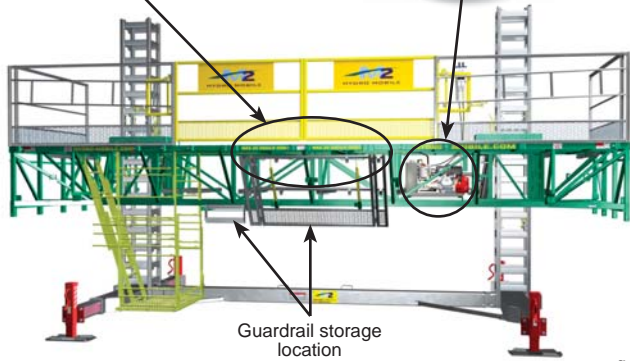
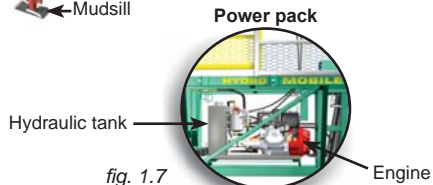
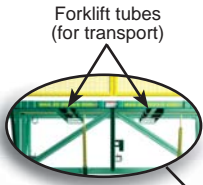
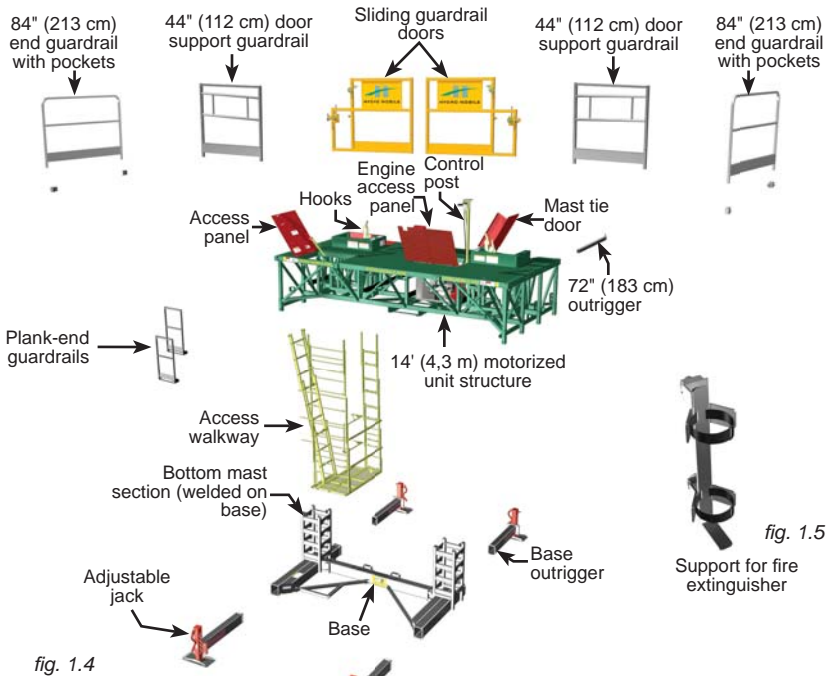

24' (7,3 m) motorized unit shown in this illustration

Motorized Unit Specifications

General Specifications				
		24' (7,3 m) model		14' (4,3 m) model
Dimensions of the motorized unit (as shipped)		84" x 288" x 48" (2,1 m x 7,3 m x 1,2 m)		84" x 168" x 48" (2,1 m x 4,3 m x 1,2 m)
Drive system		Hydraulic ratchet drive		Hydraulic ratchet drive
Maximum height		250' (76 m)		250' (76 m)
Distance between tie levels		Up to 30' (9,14 m) if mast ties are pre-installed (refer to <i>Masts and Mast Ties</i> section for complete information)		Up to 30' (9,14 m) if mast ties are pre-installed (refer to <i>Masts and Mast Ties</i> section for complete information)
Freestanding height		35' (10,1 m) with extended telescopic base outriggers		25' (7,6 m) with extended telescopic base outriggers
Safety devices		Safety hooks	Speed-activated hook system	Safety hooks Speed-activated hook system

fig. 1.9

Specific Features				
		24' (7,3 m) model		14' (4,3 m) model
Platform weight (as shipped)	Total	7300 lb (3311 kg)		6000 lb (2722 kg)
	Base	2300 lb (1043 kg)		1500 lb (680 kg)
	MU structure assembly	5000 lb (2268 kg)		4500 lb (2041 kg)
Maximum load capacity	Single unit installation	16,600 lb at 64' (7530 kg at 19,7 m)		19,300 lb at 34' (8754 kg at 10,4 m)
	Multiple units installation	30,000 lb at 148' (13 607 kg at 45,1 m)		32,800 lb at 108' (14 878 kg at 32,9 m)
Maximum lifting capacity		22,000 lb (9979 kg)		22,000 lb (9979 kg)
Vertical travel speed		3' (0,9 m) per minute		3' (0,9 m) per minute
Mast section		16" x 16" x 60" (40,6 cm x 40,6 cm x 1,5 m) 235 lb (107 kg) per section		16" x 16" x 60" (40,6 cm x 40,6 cm x 1,5 m) 235 lb (107 kg) per section
Bridges		Refer to the <i>Bridges</i> section for dimensions		Refer to the <i>Bridges</i> section for dimensions
Guardrails (included)		Sliding guardrail doors (2) Plank-end guardrails (2) 84" (213 cm) end guardrails (2) 84" (213 cm) door support guardrails (2)		Sliding guardrail doors (2) Plank-end guardrails (2) 84" (213 cm) end guardrails (2) 44" (112 cm) door support guardrails (2)

fig. 1.10

Motorized Unit Specifications

Hydraulic Specifications	
Component	Specifications
Double gear pump	2 x 3.18 GPM (2 x 12,02 l/min)
Hydraulic cylinder	2 x 3 1/2" x 23 1/2" x 1 1/2" (8,9 cm x 59,7 cm x 3,8 cm) with 3000 psi counterbalance
Hydraulic tank capacity	5.26 US gal (19,9 l)
Hydraulic oil	Dexron III ATF
Oil filter	Ikron filter model HE K44-20-135-AS-SP010 (HM part number A0410000-0004)

fig. 1.11

Engine Specifications		
	24' (7,3 m) model	14' (4,3 m) model
Model	Honda GX270	Honda GX270
Rated power	9 HP @ 3600 RPM	9 HP @ 3600 RPM
Consumption	313 g / kWh (230 g / hph)	313 g / kWh (230 g / hph)
Spark plug	BPR6ES	BPR6ES
Oil type	SAE 10W30	SAE 10W30
Gasoline tank capacity	1.6 US gal (6 l)	1.6 US gal (6 l)
Oil capacity	1.16 US qt (1,10 l)	1.16 US qt (1,10 l)
Electrical power supply	12 VDC – 10 Ah	12 VDC – 10 Ah
Battery	12 VC – 230 CCA	12 VC – 230 CCA
For any other information regarding the use and maintenance of Honda engines, refer to the Honda User's manual.		

fig. 1.12

Operation Specifications	
Wind exposure	
	Maximum wind speed allowed
During operation (of a setup with mast ties)	35 mph (56 km/h)
During erecting and dismantling (all types of setups), for freestanding installations and setups equipped with weather protection	28 mph (45 km/h)
When unit is not in use	94 mph (150 km/h)
A setup with mast ties should only be used on masts whose height does not exceed 250' (76 m).	
For complete information about wind speed restrictions and recommendations, see warning on p. 7.	
A freestanding setup should only be used on masts whose height does not exceed 35' (10,1 m) for 24' (7,3 m) motorized units and 25' (7,6 m) for 14' (4,3 m) motorized units, with extended telescopic base outriggers for both motorized unit models	
Noise exposure	
Standard noise level ¹ = 83 dB(A) ²	

¹ measured at 23' (7 m) @ 3600 RPM² with super silent muffler, noise level is 76 dB(A)

fig. 1.13

Motorized Unit Specifications

Weight of Components	
Description	Weight
24' (7,3 m) motorized unit	7300 lb (3311 kg)
14' (4,3 m) motorized unit	6000 lb (2722 kg)
24' (7,3 m) base assembly	2300 lb (1043 kg)
14' (4,3 m) base assembly	1500 lb (680 kg)
24' (7,3 m) structure assembly	5000 lb (2268 kg)
14' (4,3 m) structure assembly	4500 lb (2041 kg)
Mast assembly	235 lb (107 kg)
Walkway operator assembly	420 lb (191 kg)
6' (1,8 m) bearing bridge adapter assembly	900 lb (408 kg)
10' (3 m) modular bridge assembly	1360 lb (617 kg)
5' (1,5 m) modular bridge assembly	795 lb (361 kg)
Multi-purpose insert bridge assembly	800 lb (363 kg)
72" (183 cm) outrigger kit	25 lb (11 kg)
120" (305 cm) outrigger kit	55 lb (25 kg)
Sliding guardrail door - LEFT assembly for 24' (7,3 m) motorized unit	68 lb (31 kg)
Sliding guardrail door - RIGHT assembly for 24' (7,3 m) motorized unit	68 lb (31 kg)
Sliding guardrail door - LEFT assembly for 14' (4,3 m) motorized unit	50 lb (23 kg)
Sliding guardrail door - RIGHT assembly for 14' (4,3 m) motorized unit	50 lb (23 kg)
84" (213 cm) door support guardrail for 24' (7,3 m) motorized unit	70 lb (32 kg)
44" (112 cm) door support guardrail for 14' (4,3 m) motorized unit	50 lb (23 kg)
84" (213 cm) end guardrail	60 lb (27 kg)
60" (150 cm) guardrail	32 lb(15 kg)
Plank-end guardrail	30 lb (14 kg)
Movable guardrail assembly – TYPE 2	75 lb (34 kg)
Hoist main assembly	1860 lb (844 kg)
Hoist power pack rack assembly	750 lb (340 kg)
Hoist power pack bracket adapter for 14' (4,3 m) motorized unit	30 lb (15 kg)
Monorail beam assembly	85 lb (39 kg)
Junction plate assembly	19,5 lb (9,5 kg)
Monorail beam attachment assembly	27 lb (12 kg)
Weather protection – complete kit	224 lb (102 kg)
Weather protection connection tube kit	68 lb (31 kg)
Weather protection post assembly – TYPE 1	37 lb (17 kg)
Weather protection top outrigger kit	74 lb (34 kg)
Swivel bridge assembly (with guardrail)	800 lb (363 kg))
5' (1,5 m) square bridge assembly	390 lb (177 kg)
Flush bearing bridge adapter	350 lb (159 kg)
Wheel set	535 lb(243 kg)
Square bridge adapter assembly	230 lb (112 kg)

fig. 1.14

Motorized Unit Specifications

Dimensions of the Motorized Unit

24' (7,3 m) motorized unit

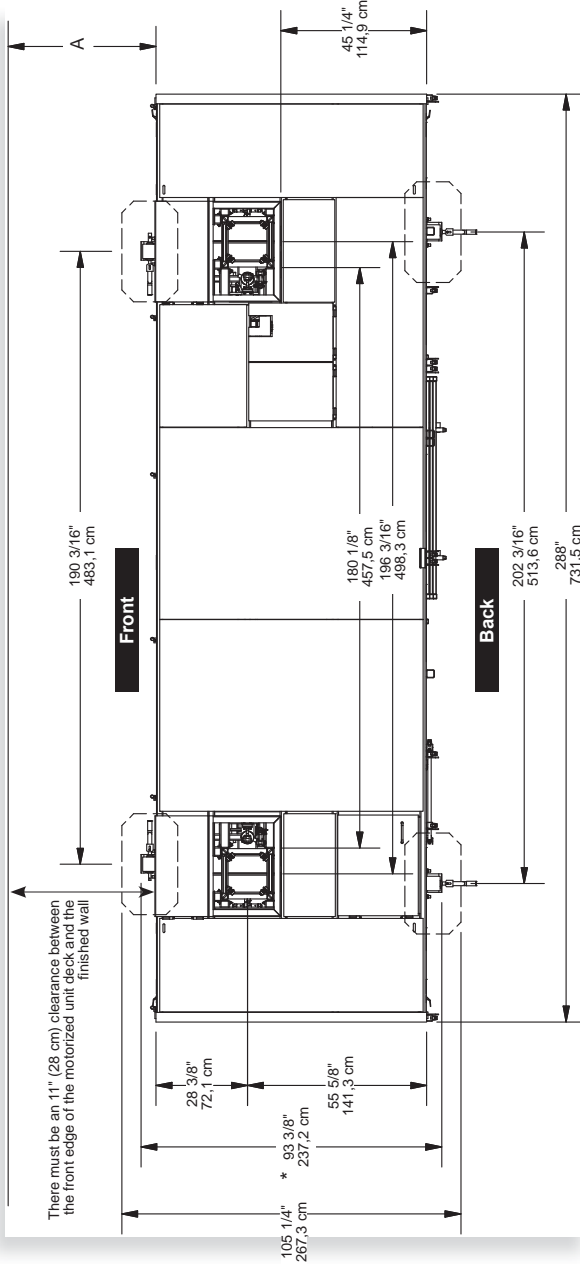

fig. 1.15

A = Distance from finished wall. For more information, refer to the general installation guidelines, on p. 18.

* 141 3/8" (359,1 cm) with outriggers fully extended

Dimensions of the Motorized Unit

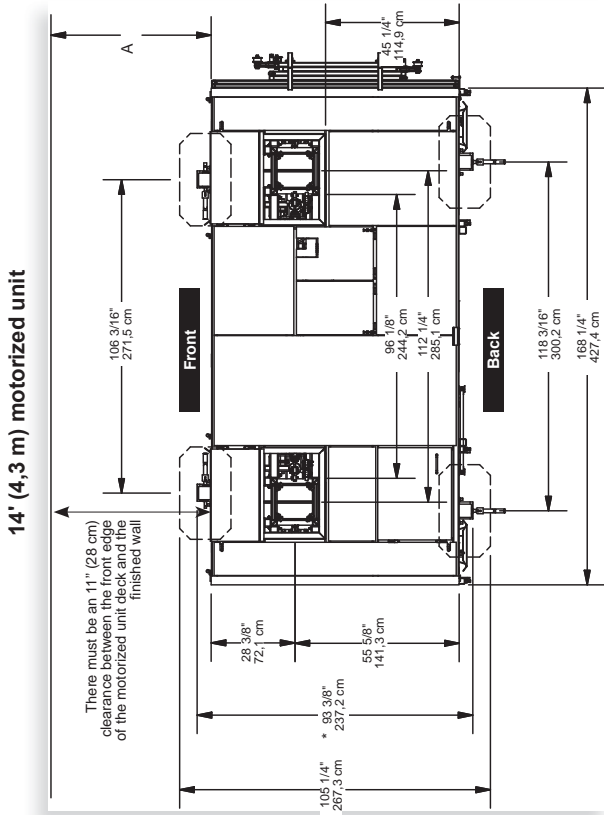

fig. 1.16

* 141 3/8" (359,1 cm) with outriggers fully extended

A = Distance from finished wall. For more information, refer to the general installation guidelines, on p. 18.

Side view dimensions
24' (7,3 m) motorized unit and 14' (4,3 m) motorized unit

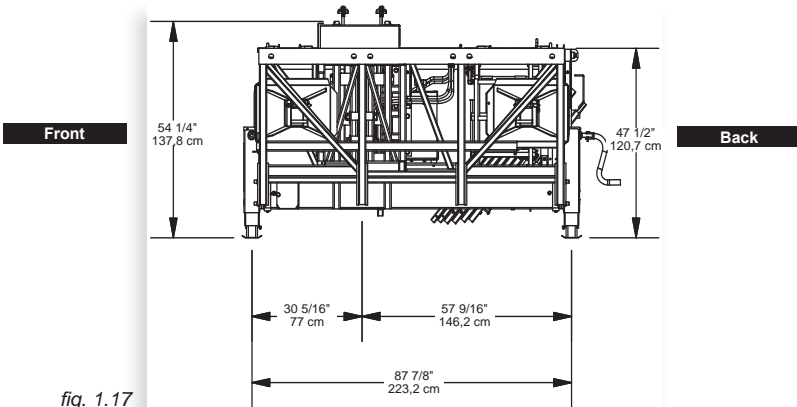

fig. 1.17

Positioning the Motorized Unit

General Concept

Bearing surface

Before installing the motorized unit, make sure the bearing surface under it is level, clear of debris and has the proper bearing capacity. When required, appropriate cribbing must be placed under the mudsills on the base to distribute the load. It is important to make sure that the bearing surface is stable and has not been subject to any type of erosion or deterioration caused by weather conditions (snow, rain, etc.).

Minimum Bearing Surface Capacities						
	Height		Motorized unit (pressure per mudsill)			Load under mast
			Mudsill: 14" x 28" (35,6 x 71 cm) Contact surface: 392 sq in (.25 m ²)			
	(ft)	(m)	Load reaction	Load pressure (psi)	Load pressure (kpa)	Load reaction
	35	10,7	15 972 lb	41	283	21 880 lb
			7245 kg			9925 kg
	50	15,2	15 005 lb	38	262	22 735 lb
			6806 kg			10 312 kg
	75	22,9	15 830 lb	40	276	23 985 lb
			7180 kg			10 879 kg
	100	30,5	16 655 lb	43	296	25 235 lb
			7556 kg			11 446 kg
	150	45,7	18 305 lb	47	324	27 735 lb
			8303 kg			12 580 kg
	200	61,0	19 955 lb	51	352	30 235 lb
			9051 kg			13 714 kg
250	76,2	21 605 lb	55	379	32 735 lb	
		9800 kg			14 848 kg	
	Freestanding installation					
	Tied installation					
Load reactions under each mast must be considered for an installation using mast base plates. For more information about mast base plates, refer to p. 115 of the <i>Accessories</i> section.						
Load reactions in above table include a dynamic factor.						

fig. 1.18

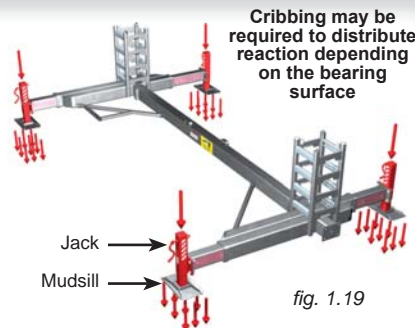

WARNING

Make sure the ground or support surface capacity meets with values included in the *Minimum Bearing Surface Capacities* table (fig. 1.18). Soil compacting, cribbing or shoring can increase bearing capacity. Contact an engineer for assistance.

Positioning the Motorized Unit

Suggested cribbing for most bearing surfaces

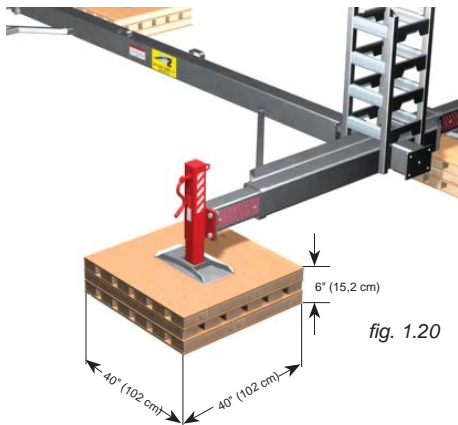

fig. 1.20

fig. 1.21

Suggested Cribbing		
40" x 40" x 6" (102 cm x 102 cm x 15,2 cm)		
①	Plywood 40" x 40" x 3/4" (102 cm x 102 cm x 1,9 cm)	2
②	2" x 10" x 40" (5 cm x 25 cm x 102 cm)	12

Values shown in the above table are for reference only. Any cribbing equivalent to or larger than these values can be used.

The plywood and lumber used as cribbing should be secured together to prevent slipping. Using screws instead of nails for securing will prolong the service life of lumber and plywood used as cribbing.

The type of cribbing chosen may vary according to the bearing surface where the setup must be installed.

For example, a setup installed on a concrete slab that is covering the bearing surface would require cribbing consisting of only one plywood panel under each mudsill while a setup installed on a concrete slab that is covering an indoor garage would require shoring in addition to plywood cribbing.

A setup installed on a bearing surface composed of gravel, sand or any such type of surface would require stronger cribbing under the mudsills.

In cases where shoring is required, it is recommended to contact an engineer for assistance.

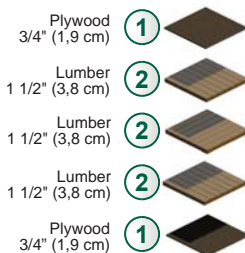

fig. 1.22

 WARNING / AVERTISSEMENT / AVISO		
<p>Make sure that support surface under jacks has sufficient bearing capacity.</p> <p>A0800100-0011</p>	<p>Veiller à ce que la capacité de charge de la surface d'appui sous les vérins soit adéquate.</p>	<p>Asegúrese que la capacidad de carga de la superficie de apoyo bajo los gatos sea la adecuada.</p>

fig. 1.23

Setup and configurations

General Guidelines

Setups with M2 Series motorized units and bridges can be freestanding or tied, depending on the equipment and accessories required and used in the configuration. A **standard configuration** is an installation that **does not require** the use of additional equipment, such as a forward extension bridge, a swivel bridge or a planking configuration wider than four planks, or the use of accessories such as weather protection, a hoist or a monorail.

It is important to note that **non standard configurations are not allowed for freestanding** M2 Series installations. It is **mandatory** to refer to the *Mast Tie Schedule* table on p. 70 of the *Masts and Mast Ties* section before the installation of any M2 Series configuration, whether freestanding or tied.

The installation of an M2 Series setup with mast ties (standard or non standard configuration) can be achieved using a **progressive installation method** or through complete **pre-installation of tie levels**. The configuration required by the layout plan and the schedule of installation of tie levels will determine which method of installation is more appropriate.

It is also important to consider that for tied installations, the combined use of equipment and accessories required to achieve a non standard configuration may not be allowed on a same installation. Refer to the *Combination of Standard and Non Standard Configurations* table in fig. 1.24 for more information on the combinations allowed.

Combination of Standard and Non Standard Configurations								
Configurations	Standard – Cantilever	Standard – Bearing bridge	5 to 8 planks	Forward extension (MPI)	Swivel bridge	Hoist and support structure	Weather protection	Monorail
	Standard – Cantilever	✓	✓	✓	✓	✓	✓	✓
Standard – Bearing bridge	✓	✓	✓	✓	✓	✓	✓	✓
Equipment → 5 to 8 planks	✓	✓	✗	✗	✗	✓	✗	✗
→ Forward extension (MPI)	✓	✓	✗	✗	✗	✓	✗	✗
→ Swivel bridge	✓	✓	✗	✗	✗	✓	✗	✗
Accessories → Hoist and support structure	✓	✓	✓	✓	✓	✗	✓	✓
→ Weather protection	✓	✓	✗	✗	✗	✓	✗	✓
→ Monorail	✓	✓	✗	✗	✗	✓	✓	✗

fig. 1.24



WARNING

Failure to select and follow the mast tie installation schedule appropriate for the configuration could adversely affect worker safety, leading to serious injury or death and equipment damage. It is **mandatory** to refer to the *Mast Tie Schedule* table on p. 70 of the *Masts and Mast Ties* section before the installation of any M2 Series configuration. It is also **mandatory** to refer to the *Load Capacities* section on p. 80 for more information about the loads allowed in a configuration. It is also recommended to review and follow the instructions included in this manual for the installation and use of each accessory and equipment to be installed.



WARNING

It is important to note that non standard configurations are not allowed for a freestanding installation.

Definition of a standard configuration

A **standard configuration**, referred to throughout this owner's manual and related documentation, is an installation that **does not require** the use of additional equipment, such as a forward extension bridge, a swivel bridge or a planking configuration wider than four planks nor the use of accessories such as weather protection, a hoist or a monorail.

It is **mandatory** to refer to the *Load Capacities* section on p. 80 for the number of bridges allowed in a standard single unit or multiple units installation.

Setup and Configurations

General Guidelines

- 1- Installation should be carried out by qualified erectors/dismantlers under the supervision of a competent person, in accordance with all applicable local regulations.
- 2- In reference to the plan/layout drawing, make sure that all the components required are available. Establish the position of the motorized unit, determine if there are obstacles and what are the cribbing and mast tie requirements.
- 3- Before installing the motorized unit, determine where the cribbing and the mudsills will rest. The bearing surface under the motorized unit should be level, clear of debris and have the proper bearing capacity (see the *Minimum Bearing Surface Capacities* table, fig. 1.18, p. 15). Should the actual bearing capacity be inferior to the values in the table, please seek instructions and recommendations from Hydro Mobile.
- 4- On **freestanding installations**, the base outriggers on the **back** of the unit must be extended completely to a total of 24" (61 cm) and locked in place with a lock pin (second hole).

The base outriggers on the **front** of the unit must be extended and locked in place to the appropriate distance according to the number of planks required and allowed for the installation, as shown in fig. 1.25, p. 19.

With the front base outriggers completely extended, the **maximum width** of planking allowed in **front** of the unit on a freestanding installation is a **three-plank** wide configuration.

- 5- On **tiered installations**, the base outriggers must be closed completely. The **maximum width** of planking allowed in **front** of the unit is an **eight-plank** wide configuration and requires the use of optional outriggers and accessories. Refer to p. 95 of the *Accessories* section for more information about outriggers and planking configurations. For more information about planking and mast ties, refer to the *Mast Tie Schedule* table on p. 70 of the *Masts and Mast Ties* section.
- 6- Distance from the finished wall (see "A" in fig. 1.15, p. 13 and fig. 1.16, p. 14) should be the number of planks multiplied by the width of one plank, while allowing 6" to 8" (15 cm to 20 cm) of play. Add an additional 2" (5 cm) if using a toe board. Refer to applicable local regulations to determine play or the maximum allowable distance between the motorized unit, including its accessories, and the face of the work.
- 7- Mark the position of mudsills while taking center-to-center distances into account. Base level differences can be compensated by adjusting the height of the base jacks or by building wood cribbing. Major differences in the level of the bearing surface or obstacles can be bypassed using mast base plates. Refer to p. 115 of the *Accessories* section for instructions on the installation and use of mast base plates.
- 8- Make sure that all loads have been removed from the platform and that all workers have stepped down before lifting and transporting the motorized unit. Refer to p. 37 for more information on the lifting and moving of a motorized unit. Unload the motorized unit with a rough terrain forklift or a crane. When moving the motorized unit with a forklift, the unit must be lifted by the designated areas on the platform (see fig. 1.6, p. 9).
- 9- Using a rough terrain forklift, a crane or an optional wheel set, position and align the motorized unit with the face of the work or the structure. Before lowering the unit on the bearing surface, lower the base jacks by 4" to 5" (11 cm to 13 cm). Refer to p. 102 of the *Accessories* section for more information about lifting and moving a motorized unit or a setup with a wheel set.
- 10- Install a mast section on each of the bottom mast sections. Refer to p. 69 of the *Masts and Mast Ties* section for instructions on how to install mast sections. Verify that each mast is plumb on both its front and side axis. If required, level the motorized unit using the adjustable jacks on the base. If mast sections remain out of plumb after adjusting the base jacks, contact the Hydro Mobile technical support team.
- 11- Remove the mast locking bar from both bottom mast sections. Store the mast locking bars in their storage location. For instructions on the removal and storage of mast locking bars, refer to p. 62 of the *Power Pack and Operating Components* section.
- 12- Remove the transport hook from each cylinder. Retrieve and install the cylinder and secondary hooks on each mast. Store the transport hooks in their storage location. For instructions on the installation and use of hooks, refer to p. 62 of the *Power Pack and Operating Components* section.

Setup and configurations

General Guidelines

- The platform can safely be accessed by the front of the mast when it is less than 10' (3 m) above base level. Once the platform has been raised over 10' (3 m) above base level, use the access ladder on the walkway to reach the platform. Make sure that the access ladder is completely extended. **To avoid any crushing hazard, the access walkway must not be used if the access ladder is not entirely extended** (as shown in fig. 1.26).
- It is also suggested to install an optional retractable rest platform when the platform has been raised at more than 30' (9 m) above base level or beyond the maximum allowable height prescribed by local regulations for mast climbing without a rest platform. Refer to p. 94 of the *Accessories* section for instructions on the installation and use of a retractable rest platform.
- Proceed to the following instruction steps for the installation of the setup, as the configuration requires.

Positioning of base outriggers

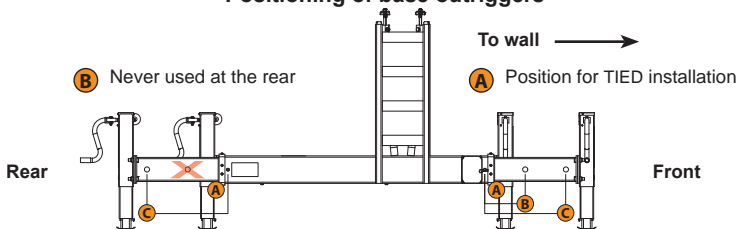

	Type of installation	Length of base outriggers
A	With mast ties	0" (0 cm)
C	Freestanding	24" (61 cm)

	Type of installation	Maximum number of planks	Length of base outriggers
A	With mast ties	As allowed	0" (0 cm)
A	Freestanding	0 - 1	0" (0 cm)
B		2	11" (28 cm)
C		3	24" (61 cm)

fig. 1.25

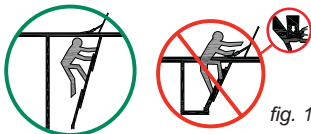

fig. 1.26

To avoid any crushing hazard, the access walkway must not be used if the access ladder is not entirely extended

Installation of a single unit configuration – freestanding

The following installation steps can be used for **standard configurations only**. Non standard configurations are not allowed for freestanding installations. For more information about the definition of a standard configuration, refer to p. 17 of this section.

Positioning the motorized unit

- Prepare the motorized unit and the area where it will be installed as described in the general guidelines on p. 18 (steps 1 through 15). Make sure that the base outriggers on the **back** of the motorized unit are completely extended and the base outriggers on the **front** of the unit are extended to the appropriate distance, as described in step 4 of the general guidelines and in fig. 1.25. Make sure all base outriggers are properly locked in place.

Installation of bridges

- With the motorized unit at base level, install as many bridges as is required and allowed. For instructions on how to install a bridge, refer to p. 43 of the *Bridges* section. Refer to the *Load Capacities* section on p. 80 for the maximum number of bridges allowed in a setup.





Setup and Configurations

Installation of a single unit configuration – freestanding

Installation of outriggers and planking

- 3- Adjust the outriggers and install planks, as required and allowed (see p. 95 of the *Accessories* section for more information).

Verification of the setup

- 4- Make a final verification of the setup before starting to install mast sections. Make sure all the guardrails are in place and secure (see p. 91 of the *Accessories* section for more information about guardrails). In all cases where workers are exposed to fall hazards greater than specified by local regulations, the installation of guardrails or face guardrail supports is **mandatory**.
- 5- Before authorizing workers to use the motorized unit, perform every step in the daily inspection checklist. If required, fill out the handover sheet to complete the installation. Refer to p. 120 of the *Transport, Storage and Maintenance* section for more information about the daily inspection checklist and to p. 124 for information about the handover sheet.

Installation of mast sections

- 6- Using a crane or a rough terrain forklift, load mast sections on the unit. **Mast sections should be stored horizontally and distributed equally on the motorized unit to ensure good balance.** Refer to the *Load Capacities* section on p. 80 for more information about loading the platform.
- 7- Proceed with the installation of mast sections. Refer to p. 69 of the *Masts and Mast Ties* section for instructions on how to install mast sections.
- 8- Install as many mast sections as required to reach the desired height, equal or inferior to the maximum allowable height for a freestanding installation, making sure throughout the process that each mast remains plumb on both its front and side axis. It is important to install mast sections alternately – one on mast, then one on the other, to ensure good balance. Refer to p. 70 of the *Masts and Mast Ties* section for more details on the maximum allowable height for a freestanding installation.
- 9- It is important to make sure to verify the mast bolts on each mast when lowering the platform to make sure they are tightened to the proper torque and are in good condition, especially on **brand-new mast sections**, as the galvanized coating may have compressed. In all cases, mast bolts must be tightened to a torque of 120 lb-ft (163 N-m). Failure to tighten bolts properly may lead to serious injury or death.



Installation of a multiple units configuration – freestanding (requires the use of two bearing bridge adapters – sold separately)

The following installation steps can be used only for a **standard configuration**. Non standard configurations are not allowed for freestanding installations. For more information about the definition of a standard configuration, refer to p. 17 of this section.

Positioning the first motorized unit

- 1- Prepare the first motorized unit and the area where the setup will be installed as described in the general guidelines on p. 18 (steps 1 through 15). Make sure that the base outriggers on the **back** of the motorized unit are completely extended and the base outriggers on the **front** of the unit are extended to the appropriate distance, as described in step 4 of the general guidelines and in fig. 1.25, p. 19. Make sure all base outriggers are properly locked in place.

Positioning the second motorized unit

- 2- Determine the position of the second motorized unit while making sure that the ideal distance is kept between the two motorized units. Refer to the installation instructions for a bearing bridge structure, on p. 46 of the *Bridges* section.



WARNING

A freestanding setup must not be raised over 35' (10,1 m) with a 24' (7,3 m) motorized unit and 25' (7,6 m) with a 14' (4,3 m) motorized unit.



Setup and configurations

Installation of a multiple units configuration – freestanding (requires the use of two bearing bridge adapters – sold separately)

Positioning the second motorized unit (cont'd)

- 3- Prepare the second motorized unit and the area where it will be installed as described in the general guidelines on p. 18 (steps 1 through 15). Make sure that the base outriggers on the **back** of the motorized unit are completely extended and the base outriggers on the **front** of the unit are extended to the appropriate distance, as described in step 4 of the general guidelines and in fig. 1.25, p. 19. Make sure all base outriggers are properly locked in place.

Installation of the bearing bridge structure and the cantilever bridges

- 4- Proceed with the installation of the bearing bridge structure and the cantilever bridges. Refer to p. 46 of the *Bridges* section for more information on the installation of a bearing bridge. It is **mandatory** to install any additional cantilever bridge **after** the bearing bridge structure has been installed to avoid throwing the structure off balance.

Installation of outriggers and planking

- 5- Adjust the outriggers and install planks, as required and allowed (see p. 95 of the *Accessories* section for more information).

Verification of the setup

- 6- Make a final verification of the setup before starting to install mast sections. Make sure all the guardrails are in place and secure (see p. 91 of the *Accessories* section for more information about guardrails). In all cases where workers are exposed to fall hazards greater than specified by local regulations, the installation of guardrails or face guardrail supports is **mandatory**.
- 7- Before authorizing workers to use the motorized units, perform every step in the daily inspection checklist. If required, fill out the handover sheet to complete the installation. Refer to p. 120 of the *Transport, Storage and Maintenance* section for more information about the daily inspection checklist and to p. 124 for information about the handover sheet.

Installation of mast sections

- 8- Using a crane or a rough terrain forklift, load mast sections on the units. **Mast sections should be stored horizontally and distributed equally on each motorized unit to ensure good balance.** Refer to the *Load Capacities* section on p. 80 for more information about loading the units.
- 9- Proceed with the installation of mast sections. Refer to p. 69 of the *Masts and Mast Ties* section for instructions on how to install mast sections.
- 10- Install as many mast sections as required on each motorized unit until the setup has reached the desired height, equal or inferior to the maximum allowable height for a freestanding installation, making sure throughout the process that each mast remains plumb on both its front and side axis. It is important to install mast sections alternately – on the first motorized unit, then on the second, to ensure good balance. Refer to p. 21 of the *Masts and Mast Ties* section for more details on the maximum allowable height for a freestanding installation.
- 11- It is important to make sure to verify the mast bolts on each mast when lowering the platform to make sure they are tightened to the proper torque and are in good condition, especially on **brand-new mast sections**, as the galvanized coating may have compressed. In all cases, mast bolts must be tightened to a torque of 120 lb-ft (163 N-m). Failure to tighten bolts properly may lead to serious injury or death.



WARNING

On freestanding installations, with the front base outriggers completely extended, the **maximum width** of planking allowed in **front** of the unit is a **three-plank** wide configuration.

Setup and Configurations

Installation of configurations with mast ties

The installation of an M2 Series setup with mast ties (standard or non standard configuration) can be achieved using a **progressive installation method** or through complete **pre-installation of tie levels**. The configuration required by the layout plan and the schedule of installation of tie levels will determine which method of installation is more appropriate. Use the tables in fig. 1.27, fig. 1.28, fig. 1.29 and the *Mast Tie Schedule* table on p. 70 of the *Masts and Mast Ties* section to guide the selection of the proper method of installation.

fig. 1.27

	STANDARD CONFIGURATION		NON STANDARD CONFIGURATION		
Method of installation of tie levels	(A) Progressive	(B) Pre-installation	(A) Progressive	(B) Pre-installation	(C) Pre-installation
Tie levels every	20' (6,1 m)	30' (9,1 m)	10' (3 m)	20' (6,1 m)	20' (6,1 m)
Standard cantilever bridges	Installed and used	Installed but not used	Installed and used	Installed but not used	Not installed
Standard bearing bridges	Installed and used	Installed but not used	Installed and used	Installed but not used	Installed but not used
5 to 8 planks			Installed and used	Not installed	Not installed
Forward extension (MPI)			Installed and used		Not installed
Swivel bridge			Installed and used		Not installed
Hoist			Installed and used	Installed but not used above last tie level	Installed but not used above last tie level
Weather protection			Installed and used	Installed but not used *	
Monorail			Installed and used	Installed but not used *	

* **Installed but not used:** accessory is installed but can only be used when tie levels have been completely installed to top of work. **Weather protection tarps must be installed only when tie level installation is complete.**

(A) PROGRESSIVE INSTALLATION OF TIE LEVELS	
Standard bridges installed and used	Standard bridges can be installed and used for workers and material
Equipment installed and used	5 to 8 plank configuration, forward extension bridge and swivel bridge can be installed and used for workers and material
Accessories installed and used	Hoist, monorail and weather protection can be installed and used

fig. 1.28

(B) (C) COMPLETE PRE-INSTALLATION OF THE TIE LEVELS TO THE TOP OF THE WORK	
Standard bridges installed but not used	Any required and allowed standard bridges (cantilever or bearing) can be installed but cannot be used for material or workers until tie levels are complete to the top of the work. For example, mast sections can be loaded on the motorized unit only, not on bridges.
Standard cantilever bridges must not be installed; bearing bridge can be installed but not used	Any required and allowed standard cantilever bridge must not be installed until tie levels are complete to the top of the work. Any required and allowed standard bearing bridge can be installed but not used until tie levels are complete to the top of the work.
Equipment can be installed but not used	Any required and allowed additional equipment – 5 to 8 plank configuration, forward extension bridge and swivel bridge – can be installed but cannot be used until tie levels are complete to the top of the work.
Accessories installed but not used	Any required and allowed accessory – monorail and weather protection (structure only) – can be installed but cannot be used until tie levels are complete to the top of the work. Weather protection tarps must be installed only when tie level installation is complete.
Hoist installed but not used above last tie level	If required and allowed, the hoist can be installed and used to load mast sections only but cannot be used above the last tie level installed.

fig. 1.29



Setup and configurations

Single unit configuration with mast ties – progressive installation



The following installation steps can be used for both **standard and non-standard configurations** with mast ties. For more information about the definition of a standard configuration, refer to p. 17 of this section.

Positioning the motorized unit

- 1- Prepare the motorized unit and the area where the setup will be installed as described in the general guidelines on p. 18 (steps 1 through 15). Make sure that all base outriggers are completely closed.

Installation of bridges, accessories and additional equipment

- 2- With the motorized unit at base level, install as many bridges as is required and allowed. For instructions on how to install a bridge, refer to p. 43 of the *Bridges* section. Refer to the *Load Capacities* section on p. 80 for the maximum number of bridges allowed in a setup.
- 3- Install accessories and additional equipment as is required and allowed. For information about the combined use of equipment and accessories allowed for a configuration, refer to the *Combination of Standard and Non Standard Configurations* table in fig. 1.24, p. 17. For instructions on the installation and use of forward extension or swivel bridges, refer to the *Bridges* section on p. 43. For instructions on the installation and use of a 5 to 8 plank configuration, a hoist, a monorail or weather protection, refer to the *Accessories* section on p. 91.

Installation of outriggers and planking

- 4- Adjust the outriggers and install planks, as required and allowed (see p. 95 of the *Accessories* section for more information).

Verification of the setup

- 5- Make a final verification of the setup before starting to install mast sections. Make sure all the guardrails are in place and secure (see p. 91 of the *Accessories* section for more information about guardrails). In all cases where workers are exposed to fall hazards greater than specified by local regulations, the installation of guardrails or face guardrail supports is **mandatory**.
- 6- Before authorizing workers to use the motorized unit, perform every step in the daily inspection checklist. If required, fill out the handover sheet to complete the installation. Refer to p. 120 of the *Transport, Storage and Maintenance* section for more information about the daily inspection checklist and to p. 124 for information about the handover sheet.

Installation of mast sections and mast ties

- 7- Using a crane or a rough terrain forklift, load mast sections on the unit. **Mast sections should be stored horizontally and distributed equally on the motorized unit to ensure good balance.** Refer to the *Load Capacities* section on p. 80 for more information about loading the platform.
- 8- Install mast sections until a first tie level is required. Refer to p. 69 of the *Mast and Mast Ties* section for instructions on how to install mast sections. It is important to install mast sections alternately – one on one mast, then one on the other, to ensure good balance. For more information about the schedule of installation of tie levels, refer to the *Mast Tie Schedule* table on p. 70 of the *Masts and Mast Ties* section. Refer to p. 70 of the *Masts and Mast Ties* section for instructions on how to install mast ties.
- 9- Install as many mast sections as the plan layout requires and as is allowed. A setup with mast ties should not be raised above 250' (76 m). Make sure throughout the process that each mast remains plumb on both its front and side axis and that tie levels are installed when required.
- 10- It is important to make sure to verify the mast bolts on each mast when lowering the platform to make sure they are tightened to the proper torque and are in good condition, especially on **brand-new mast sections**, as the galvanized coating may have compressed. In all cases, mast bolts must be tightened to a torque of 120 lb-ft (163 N-m). Failure to tighten bolts properly may lead to serious injury or death.



Setup and configurations

Multiple units configuration with mast ties – progressive installation (requires the use of two bearing bridge adapters – sold separately)

- A** The following installation steps can be used for both **standard and non-standard configurations** with mast ties. For more information about the definition of a standard configuration, refer to p. 17 of this section.

Positioning the first motorized unit

- 1- Prepare the first motorized unit and the area where the setup will be installed as described in the general guidelines on p. 18 (steps 1 through 15). Make sure that all base outriggers are completely closed.

Positioning the second motorized unit

- 2- Determine the position of the second motorized unit while making sure that the ideal distance is kept between the two motorized units. Refer to the installation instructions for a bearing bridge structure, on p. 46 of the *Bridges* section.
- 3- Prepare the second motorized unit and the area where it will be installed as described in the general guidelines on p. 18 (steps 1 through 15).

Installation of the bearing bridge structure and the cantilever bridges

- 4- Proceed with the installation of the bearing bridge structure and the cantilever bridges. Refer to p. 46 of the *Bridges* section for more information on the installation of a bearing bridge. It is **mandatory** to install any additional cantilever bridge **after** the bearing bridge structure has been installed to avoid throwing the structure off balance.

Installation of accessories and additional equipment

- 5- Install accessories and additional equipment as is required and allowed. For information about the combined use of equipment and accessories allowed for a configuration, refer to the *Combination of Standard and Non Standard Configurations* table in fig. 1.24, p. 17. For instructions on the installation and use of forward extension or swivel bridges, refer to the *Bridges* section on p. 43. For instructions on the installation and use of a 5 to 8 plank configuration, a hoist, a monorail or weather protection, refer to the *Accessories* section on p. 91.

Installation of outriggers and planking

- 6- Adjust the outriggers and install planks, as required and allowed (see p. 95 of the *Accessories* section for more information).

Verification of the setup

- 7- Make a final verification of the setup before starting to install mast sections. Make sure all the guardrails are in place and secure (see p. 91 of the *Accessories* section for more information about guardrails). In all cases where workers are exposed to fall hazards greater than specified by local regulations, the installation of guardrails or face guardrail supports is **mandatory**.
- 8- Before authorizing workers to use the motorized units, perform every step in the daily inspection checklist. If required, fill out the handover sheet to complete the installation. Refer to p. 120 of the *Transport, Storage and Maintenance* section for more information about the daily inspection checklist and to p. 124 for information about the handover sheet.

Installation of mast sections and tie levels

- 9- Using a crane or a rough terrain forklift, load mast sections on the units. **Mast sections should be stored horizontally and distributed equally on each motorized unit to ensure good balance.** Refer to the *Load Capacities* section on p. 80 for more information about loading the units.

Setup and configurations

Multiple units configuration with mast ties – progressive installation (requires the use of two bearing bridge adapters – sold separately)



Installation of mast sections and tie levels (cont'd)

- 10- Install mast sections until a first tie level is required. Refer to p. 69 of the *Mast and Mast Ties* section for instructions on how to install mast sections. It is important to install mast sections alternately – on the first motorized unit, then on the second, to ensure good balance. For more information about the schedule of installation of tie levels, refer to the *Mast Tie Schedule* table on p. 70 of the *Masts and Mast Ties* section. Refer to p. 70 of the *Masts and Mast Ties* section for instructions on how to install mast ties.
- 11- Install as many mast sections as the plan layout requires and as is allowed. A setup with mast ties should not be raised above 250' (76 m). Make sure throughout the process that each mast remains plumb on both its front and side axis and that tie levels are installed when required.
- 12- It is important to make sure to verify the mast bolts on each mast when lowering the platform to make sure they are tightened to the proper torque and are in good condition, especially on **brand-new mast sections**, as the galvanized coating may have compressed. In all cases, mast bolts must be tightened to a torque of 120 lb-ft (163 N-m). Failure to tighten bolts properly may lead to serious injury or death.



To access the work platform by climbing up the mast once the setup has been raised over 10' (3 m) above base level, it is recommended to use the access ladder on the walkway. It is also suggested to install a retractable rest platform when the setup is at a height over 30' (9 m) above base level or beyond the maximum allowable height prescribed by local regulations for mast climbing without a rest platform.

Single unit configuration with mast ties – pre-installation



The following installation steps can be used for a **standard configuration**. The following steps also apply to a **non-standard configuration equipped with accessories but not requiring additional equipment**. Refer to fig. 1.27, fig. 1.28 and fig. 1.29 on p. 22, for details about the restrictions and allowances for a configuration. Refer also to p. 17 of this section for more information about standard and non standard configurations.

Positioning the motorized unit

- 1- Prepare the motorized unit and the area where the setup will be installed as described in the general guidelines on p. 18 (steps 1 through 15). Make sure that all base outriggers are completely closed.

Installation of bridges and accessories

- 2- With the motorized unit at base level, install as many bridges as is required and allowed. For instructions on how to install a bridge, refer to p. 43 of the *Bridges* section. Refer to the *Load Capacities* section on p. 80 for the maximum number of bridges allowed in a setup. It is important to note that **loads cannot be applied on bridges during pre-installation**.
- 3- If required and allowed, install the hoist. It is important to note that during pre-installation, the hoist can be used **only** to handle mast sections and cannot be used above the last tie level installed. For information on the installation and use of the hoist, refer to p. 103 of the *Accessories* section.



WARNING

During pre-installation, only mast sections can be loaded on the motorized unit. It is important to note that no loads are allowed on the bridges until the pre-installation process is complete.



Setup and configurations

Single unit configuration with mast ties – pre-installation

Installation of bridges and accessories (cont'd)

- 4- Install all other accessories as is required and allowed. It is important to note that any **accessory installed**, with exception of the hoist, **cannot be used** until all required tie levels have been completely installed to the top of the work. If weather protection is required, only the structure can be installed. Tarps and shields can only be installed once all required tie levels are in place.

For information about the combined use of accessories allowed for a configuration, refer to the *Combination of Standard and Non Standard Configurations* table in fig. 1.24, p. 17. For instructions on the installation and use of a monorail or weather protection, refer to the *Accessories* section on p. 91.

Installation of outriggers and planking

- 5- Adjust the outriggers and install planks, as required and allowed (see p. 95 of the *Accessories* section for more information).

Verification of the setup

- 6- Make a final verification of the setup before starting to install mast sections. Make sure all the guardrails are in place and secure (see p. 91 of the *Accessories* section for more information about guardrails). In all cases where workers are exposed to fall hazards greater than specified by local regulations, the installation of guardrails or face guardrail supports is **mandatory**.

Installation of mast sections and mast ties

- 7- Using a crane or a rough terrain forklift, load mast sections on the unit. **Mast sections should be stored horizontally and distributed equally on the motorized unit to ensure good balance.** Refer to the *Load Capacities* section on p. 80 for more information about loading the platform.
- 8- Install mast sections until a first tie level is required. Refer to p. 69 of the *Mast and Mast Ties* section for instructions on how to install mast sections. It is important to install mast sections alternately – one on one mast, then one on the other, to ensure good balance. For more information about the schedule of installation of tie levels, refer to the *Mast Tie Schedule* table on p. 70 of the *Masts and Mast Ties* section. Refer to p. 70 of the *Masts and Mast Ties* section for instructions on how to install mast ties.
- 9- Install as many mast sections and tie levels as the plan layout requires and as is allowed. A setup with mast ties should not be raised above 250' (76 m). Make sure throughout the process that each mast remains plumb on both its front and side axis and that tie levels are installed when required.
- 10- It is important to make sure to verify the mast bolts on each mast when lowering the platform to make sure they are tightened to the proper torque and are in good condition, especially on **brand-new mast sections**, as the galvanized coating may have compressed. In all cases, mast bolts must be tightened to a torque of 120 lb-ft (163 N-m). Failure to tighten bolts properly may lead to serious injury or death.

Preparing for operation

- 11- Once all tie levels are in place, all accessories can be used and weather protection tarps and shields, if required, can be installed.
- 12- Before authorizing workers to use the motorized unit, perform every step in the daily inspection checklist. If required, fill out the handover sheet to complete the installation. Refer to p. 120 of the *Transport, Storage and Maintenance* section for more information about the daily inspection checklist and to p. 124 for information about the handover sheet.



WARNING

During pre-installation, the hoist can **only** be used to load mast sections. It is important to note that the hoist cannot be used above the last tie level installed.



Setup and configurations

Multiple units configuration with mast ties – pre-installation (requires the use of two bearing bridge adapters – sold separately)



The following installation steps can be used for a **standard configuration**. The following steps also apply to a **non-standard configuration equipped with accessories but not requiring additional equipment**. Refer to fig. 1.27, fig. 1.28 and fig. 1.29 on p. 22, for details about the restrictions and allowances for a configuration. Refer also to p. 17 of this section for more information about standard and non standard configurations.

Positioning the first motorized unit

- 1- Prepare the first motorized unit and the area where the setup will be installed as described in the general guidelines on p. 18 (steps 1 through 15). Make sure that all base outriggers are completely closed.

Positioning the second motorized unit

- 2- Determine the position of the second motorized unit while making sure that the ideal distance is kept between the two motorized units. Refer to the installation instructions for a bearing bridge structure, on p. 46 of the *Bridges* section.
- 3- Prepare the second motorized unit and the area where it will be installed as described in the general guidelines on p. 18 (steps 1 through 15). Make sure that all base outriggers are completely closed.

Installation of the bearing bridge structure and the cantilever bridges

- 4- Proceed with the installation of the bearing bridge structure and cantilever bridges. Refer to p. 46 of the *Bridges* section for more information on the installation of a bearing bridge. It is **mandatory** to install any additional cantilever bridge **after** the bearing bridge structure has been installed to avoid throwing the structure off balance. It is important to note that **loads cannot be applied on bridges during pre-installation**.

Installation of accessories

- 5- If required and allowed, install the hoist(s). It is important to note that during pre-installation, any hoist installed can be used **only** to handle mast sections and cannot be used above the last tie level installed. For information on the installation and use of the hoist, refer to p. 103 of the *Accessories* section.
- 6- Install all other accessories as is required and allowed. It is important to note that any **accessory installed**, with exception of the hoist, **cannot be used** until all required tie levels have been completely installed to the top of the work. If weather protection is required, only the structure can be installed. Tarps and shields can only be installed once all required tie levels are in place. For instructions on the installation and use of a monorail or weather protection, refer to the *Accessories* section on p. 91.
For information about the combined use of accessories allowed for a configuration, refer to the *Combination of Standard and Non Standard Configurations* table in fig. 1.24, p. 17. For instructions on the installation and use of a monorail or weather protection, refer to the *Accessories* section on p. 91.

Installation of outriggers and planking

- 7- Adjust the outriggers and install planks, as required and allowed (see p. 95 of the *Accessories* section for more information).

Verification of the setup

- 8- Make a final verification of the setup before starting to install mast sections. Make sure all the guardrails are in place and secure (see p. 91 of the *Accessories* section for more information about guardrails). In all cases where workers are exposed to fall hazards greater than specified by local regulations, the installation of guardrails or face guardrail supports is **mandatory**.

Setup and configurations

Multiple units configuration with mast ties – pre-installation

(requires the use of two bearing bridge adapters – sold separately)



B

Installation of mast sections and mast ties

- 9- Using a crane or a rough terrain forklift, load mast sections on the units. **Mast sections should be stored horizontally and distributed equally on each motorized unit to ensure good balance.** Refer to the *Load Capacities* section on p. 80 for more information about loading the units.
- 10- Install mast sections until a first tie level is required. Refer to p. 69 of the *Mast and Mast Ties* section for instructions on how to install mast sections. It is important to install mast sections alternately – on the first motorized unit, then on the second, to ensure good balance. For more information about the schedule of installation of tie levels, refer to the *Mast Tie Schedule* table on p. 70 of the *Masts and Mast Ties* section. Refer to p. 70 of the *Masts and Mast Ties* section for instructions on how to install mast ties.
- 11- Install as many mast sections as the plan layout requires and as is allowed. A setup with mast ties should not be raised above 250' (76 m). Make sure throughout the process that each mast remains plumb on both its front and side axis and that tie levels are installed when required.
- 12- It is important to make sure to verify the mast bolts on each mast when lowering the platform to make sure they are tightened to the proper torque and are in good condition, especially on **brand-new mast sections**, as the galvanized coating may have compressed. In all cases, mast bolts must be tightened to a torque of 120 lb-ft (163 N-m). Failure to tighten bolts properly may lead to serious injury or death.

Preparing for operation

- 13- Once all tie levels are in place, all accessories can be used and weather protection tarps and shields, if required, can be installed.
- 14- Before authorizing workers to use the motorized unit, perform every step in the daily inspection checklist. If required, fill out the handover sheet to complete the installation. Refer to p. 120 of the *Transport, Storage and Maintenance* section for more information about the daily inspection checklist and to p. 124 for information about the handover sheet.



WARNING

During pre-installation, when weather protection is required and allowed, only the structure can be installed. Tarps and shields must only be installed once all tie levels are in place up to the top of the work.



Single unit configuration with mast ties – pre-installation

The following installation steps can be used for a **non-standard configuration requiring additional equipment but no accessories other than a hoist.** Refer to fig. 1.27, fig. 1.28 and fig. 1.29 on p. 22, for details about the restrictions and allowances for a configuration. Refer also to p. 17 of this section for more information about standard and non standard configurations.

C

Positioning the motorized unit

- 1- Prepare the motorized unit and the area where the setup will be installed as described in the general guidelines on p. 18 (steps 1 through 15). Make sure that all base outriggers are completely closed.

It is important to note that cantilever bridges must not be installed until all tie levels are in place.

Setup and configurations



Single unit configuration with mast ties – pre-installation

Installation of the hoist

- 2- If required and allowed, install a hoist. It is important to note that during pre-installation, the hoist can be used **only** to handle mast sections and cannot be used above the last tie level installed. For information on the installation and use of the hoist, refer to p. 103 of the *Accessories* section.

Verification of the setup

- 3- Make a final verification of the setup before starting to install mast sections. Make sure all the guardrails are in place and secure (see p. 91 of the *Accessories* section for more information about guardrails). In all cases where workers are exposed to fall hazards greater than specified by local regulations, the installation of guardrails or face guardrail supports is **mandatory**.

Installation of mast sections and mast ties

- 4- Using a crane or a rough terrain forklift, load mast sections on the unit. **Mast sections should be stored horizontally and distributed equally on the motorized unit to ensure good balance.** Refer to the *Load Capacities* section on p. 80 for more information about loading the platform.
- 5- Install mast sections until a first tie level is required. Refer to p. 69 of the *Mast and Mast Ties* section for instructions on how to install mast sections. It is important to install mast sections alternately – one on one mast, then one on the other, to ensure good balance. For more information about the schedule of installation of tie levels, refer to the *Mast Tie Schedule* table on p. 70 of the *Masts and Mast Ties* section. Refer to p. 70 of the *Masts and Mast Ties* section for instructions on how to install mast ties.
- 6- Install as many mast sections as the plan layout requires and as is allowed. A setup with mast ties should not be raised above 250' (76 m). Make sure throughout the process that each mast remains plumb on both its front and side axis and that tie levels are installed when required.
- 7- It is important to make sure to verify the mast bolts on each mast when lowering the platform to make sure they are tightened to the proper torque and are in good condition, especially on **brand-new mast sections**, as the galvanized coating may have compressed. In all cases, mast bolts must be tightened to a torque of 120 lb-ft (163 N-m). Failure to tighten bolts properly may lead to serious injury or death.

Installation of bridges and additional equipment

- 8- With the motorized unit at base level, install as many bridges as is required and allowed. For instructions on how to install a bridge, refer to p. 43 of the *Bridges* section. Refer to the *Load Capacities* section on p. 80 for the maximum number of bridges allowed in a setup. It is important to note that **loads cannot be applied on bridges during pre-installation.**
- 9- Install additional equipment as is required and allowed. For information about the combined use of equipment and accessories allowed for a configuration, refer to the *Combination of Standard and Non Standard Configurations* table in fig. 1.24, p. 17. For instructions on the installation and use of forward extension or swivel bridges, refer to the *Bridges* section on p. 43.

Installation of outriggers and planking

- 10- Adjust the outriggers and install planks, as required and allowed (see p. 95 of the *Accessories* section for more information).

Preparing for operation

- 11- Once all tie levels are in place, the hoist can be used as required.
- 12- Before authorizing workers to use the motorized unit, perform every step in the daily inspection checklist. If required, fill out the handover sheet to complete the installation. Refer to p. 120 of the *Transport, Storage and Maintenance* section for more information about the daily inspection checklist and to p. 124 for information about the handover sheet.



Setup and configurations

Multiple units configuration with mast ties – pre-installation (requires the use of two bearing bridge adapters – sold separately)

The following installation steps can be used for a **non-standard configuration requiring additional equipment but no accessories other than a hoist**. Refer to fig. 1.27, fig. 1.28 and fig. 1.29 on p. 22, for details about the restrictions and allowances for a configuration. Refer also to p. 17 of this section for more information about standard and non standard configurations.



Positioning the first motorized unit

- 1- Prepare the first motorized unit and the area where the setup will be installed as described in the general guidelines on p. 18 (steps 1 through 15). Make sure that all base outriggers are completely closed.

Positioning the second motorized unit

- 2- Determine the position of the second motorized unit while making sure that the ideal distance is kept between the two motorized units. Refer to the installation instructions for a bearing bridge structure, on p. 46 of the *Bridges* section.
- 3- Prepare the second motorized unit and the area where it will be installed as described in the general guidelines on p. 18 (steps 1 through 15).

Installation of the bearing bridge structure

- 4- Proceed with the installation of the bearing bridge structure. Refer to steps 1 through 12 **only** of the installation instructions for a bearing bridge structure on p. 46 of the *Bridges* section. Cantilever bridges **must not be installed at this point**. It is important to note that **loads cannot be applied on bridges during pre-installation**.

It is important to note that cantilever bridges must not be installed until all tie levels are in place.

Installation of the hoist

- 5- If required and allowed, install the hoist(s). It is important to note that during pre-installation, any hoist installed can be used **only** to handle mast sections and cannot be used above the last tie level installed. For information on the installation and use of the hoist, refer to p. 103 of the *Accessories* section.

Verification of the setup

- 6- Make a final verification of the setup before starting to install mast sections. Make sure all the guardrails are in place and secure (see p. 91 of the *Accessories* section for more information about guardrails). In all cases where workers are exposed to fall hazards greater than specified by local regulations, the installation of guardrails or face guardrail supports is **mandatory**.

Installation of mast sections and mast ties

- 7- Using a crane or a rough terrain forklift, load mast sections on the units. **Mast sections should be stored horizontally and distributed equally on each motorized unit to ensure good balance**. Refer to the *Load Capacities* section on p. 80 for more information about loading the units.
- 8- Install mast sections until a first tie level is required. Refer to p. 69 of the *Mast and Mast Ties* section for instructions on how to install mast sections. It is important to install mast sections alternately – on the first motorized unit, then on the second, to ensure good balance. For more information about the schedule of installation of tie levels, refer to the *Mast Tie Schedule* table on p. 70 of the *Masts and Mast Ties* section. Refer to p. 70 of the *Masts and Mast Ties* section for instructions on how to install mast ties.



Setup and configurations

Multiple units configuration with mast ties – pre-installation (requires the use of two bearing bridge adapters – sold separately)

Installation of mast sections and mast ties (cont'd)

- 9- Install as many mast sections as the plan layout requires and as is allowed. A setup with mast ties should not be raised above 250' (76 m). Make sure throughout the process that each mast remains plumb on both its front and side axis and that tie levels are installed when required.
- 10- It is important to make sure to verify the mast bolts on each mast when lowering the platform to make sure they are tightened to the proper torque and are in good condition, especially on **brand-new mast sections**, as the galvanized coating may have compressed. In all cases, mast bolts must be tightened to a torque of 120 lb-ft (163 N-m). Failure to tighten bolts properly may lead to serious injury or death.

Installation of cantilever bridges and additional equipment

- 11- With the motorized unit at base level, proceed with the installation of cantilever bridges at the ends of the motorized units opposite to the bearing structure, as required and allowed. Refer to p. 44 of the *Bridges* section for instructions on the installation of a cantilever bridge and to the *Load Capacities* section on p. 80 for the maximum number of bridges allowed in a setup.
- 12- Install additional equipment as is required and allowed. For information about the combined use of equipment and accessories allowed for a configuration, refer to the *Combination of Standard and Non Standard Configurations* table in fig. 1.24, p. 17. For instructions on the installation and use of forward extension or swivel bridges, refer to the *Bridges* section on p. 43. For instructions on the installation and use of a 5 to 8 plank configuration, refer to the *Accessories* section on p. 91.

Installation of outriggers and planking

- 13- Adjust the outriggers and install planks, as required and allowed (see p. 95 of the *Accessories* section for more information).

Preparing for operation

- 14- Once all tie levels are in place, the hoist can be used as required.
- 15- Before authorizing workers to use the motorized unit, perform every step in the daily inspection checklist. If required, fill out the handover sheet to complete the installation. Refer to p. 120 of the *Transport, Storage and Maintenance* section for more information about the daily inspection checklist and to p. 124 for information about the handover sheet.



WARNING

During pre-installation, only mast sections can be loaded on the motorized unit. It is important to note that no loads are allowed on the bridges until the pre-installation process is complete.



WARNING

During pre-installation, the hoist can **only** be used to load mast sections. It is important to note that the hoist cannot be used above the last tie level installed.

Setup and configurations

Dismantling an installation

SAFETY comes first. It is essential that the **dismantling** of an M2 Series motorized unit setup be carried out by qualified erectors/dismantlers under the supervision of a **competent person** and be performed with the same care and precaution taken during the installation.

It is mandatory to make sure that the motorized unit installation remains stable and secure throughout the dismantling maneuvers. For the definition of a qualified erector/dismantler, refer to p. 5 of this section.

Safety guidelines for dismantling an installation

- 1- Make sure all the equipment necessary for a safe dismantlement of the installation is on hand (slings, crane or rough terrain forklift, etc., as required).
- 2- Perform every step in the daily inspection checklist. Refer to p. 120 of the *Transport, Storage and Maintenance* section for more information about the daily inspection checklist.
- 3- Make sure to choose the appropriate method for dismantling the installation. For more information about standard and non standard configurations, refer to p. 17 of this section. For instructions on the dismantling of an installation using adapter bases for sidewalk canopy installation, refer to p. 114 of the *Accessories* section. For installation using mast base plates, refer to p. 116 of the *Accessories* section for dismantling guidelines.

Dismantling a standard single unit installation – freestanding

- 1- Prepare the installation as described in the safety guidelines for dismantling an M2 Series installation above.
- 2- Bring the motorized unit to the top of the work, verifying mast bolts on each mast on the way up. Make sure that all mast bolts are tightened at the appropriate torque.
- 3- Lower the motorized unit to base level, removing mast sections on the way down. Refer to p. 75 of the *Masts and Mast Ties* section for instructions on how to remove and transport mast sections. **Mast sections should be stored horizontally and distributed equally on the motorized unit to ensure good balance.**
- 4- Once at base level, remove all loads from the platform and make all workers step down.
- 5- Remove all planking, push in all outriggers and secure in place. Remove and store all guardrails. For instructions on the removal and storage of guardrails, refer to p. 118 of the *Transport, Storage and Maintenance* section.
- 6- Remove all installed cantilever bridges on each side of the motorized unit.
- 7- Push in and close all base outriggers.
- 8- If the unit is to be stored for any significant length of time, refer to p. 118 of the *Transport, Storage and Maintenance* section for instructions on how to properly store an M2 Series motorized unit.

Dismantling a standard multiple units installation – freestanding

- 1- Prepare the installation as described in the safety guidelines for dismantling an M2 Series installation above.
- 2- Bring the motorized units to the top of the work, verifying mast bolts on each mast on the way up. Make sure that all mast bolts are tightened at the appropriate torque.



WARNING

It is essential that the **dismantling** of an M2 Series motorized unit setup be carried out with the same care and precaution taken during the installation.

Setup and configurations

Dismantling an installation



Dismantling a standard multiple units installation – freestanding

- 3- Lower the motorized units linked by a bearing bridge until the units are two rungs (20" or 50 cm) above base level, removing mast sections on the way down. To make sure that the installation remains stable, remove mast sections alternately – on one motorized unit, then one on the other. Refer to p. 75 of the *Masts and Mast Ties* section for instructions on how to remove and transport mast sections. **Mast sections should be stored horizontally and distributed equally on the motorized units to ensure good balance.**
- 4- Once at base level, remove all loads from the platform and make all workers step down.
- 5- Remove all planking, push in all outriggers and secure in place. Remove and store all guardrails. For instructions on the removal and storage of guardrails, refer to p. 118 of the *Transport, Storage and Maintenance* section.
- 6- First remove any installed cantilever bridge, then dismantle the bearing bridge structure as described in the instructions on p. 48 of the *Bridges* section.
- 7- Push in and close all base outriggers.
- 8- If any of the units is to be stored for any significant length of time, refer to p. 118 of the *Transport, Storage and Maintenance* section for instructions on how to properly store an M2 Series motorized unit.



WARNING

It is **mandatory** to make sure that **all tension (or compression) is released** from the mast tie before attempting to unpin it from the wall tie



Dismantling a single unit installation with mast ties

A

B

The following dismantling steps can be used for a **standard configuration**. The following steps also apply to a **non-standard configuration equipped with accessories but no additional equipment**. Refer to fig. 1.27, fig. 1.28 and fig. 1.29 on p. 22, for details about the restrictions and allowances for a configuration. Refer also to p. 17 of this section for more information about standard and non standard configurations.

- 1- Prepare the installation as described in the safety guidelines for dismantling an M2 Series installation, on p. 32.
- 2- If the installation is equipped with weather protection, remove all tarps and shields before the start of dismantling operations.
- 3- It is important to note that any installed **monorail must not be used** during dismantling operations.
- 4- It is important to consider that any installed hoist can **only** be used to unload mast sections and cannot be used above the last tie level installed.
- 5- Bring the motorized unit to the top of the work, verifying mast bolts and mast ties on each mast on the way up. Make sure that all mast bolts are tightened at the appropriate torque and that all mast ties are properly tied to the face of the work.



WARNING

Tarps and shields used for weather protection **must be removed before the start of dismantling operations**. Any installed monorail must not be used during dismantling operations.



WARNING

During dismantling, a hoist can **only** be used to unload mast sections and cannot be used above the last tie level installed.

Setup and configurations

Dismantling an installation



Dismantling a single unit installation with mast ties

- 6- Lower the motorized unit to base level, removing all mast sections and mast ties on the way down. Refer to p. 75 of the *Masts and Mast Ties* section for instructions on how to remove and transport mast sections. Refer to p. 75 of the *Masts and Mast Ties* section for instructions on how to remove mast ties. **Mast sections should be stored horizontally and distributed equally on the motorized unit to ensure good balance.**
- 7- Make sure to avoid overloading the motorized unit. On higher installations, it may be required to use a crane to remove mast sections from the motorized unit to avoid any overloads. Refer to the *Load Capacities* section on p. 80 of for more information about loads allowed on a motorized unit.
- 8- Once at base level, remove any installed accessory such as hoist, monorail and weather protection structure.
- 9- Remove all loads from the platform and make all workers step down.
- 10- Remove all planking, push in all outriggers and secure in place. Remove and store all guardrails. For instructions on the removal and storage of guardrails, refer to p. 118 of the *Transport, Storage and Maintenance* section.
- 11- Remove all installed cantilever bridges on each side of the motorized unit.
- 12- If the unit is to be stored for any significant length of time, refer to p. 118 of the *Transport, Storage and Maintenance* section for instructions on how to properly store an M2 Series motorized unit.



WARNING

It is **mandatory** to make sure that **all tension (or compression) is released** from the mast tie before attempting to unpin it from the wall tie



Dismantling a standard multiple units installation – with mast ties

The following dismantling steps can be used for a **standard configuration**. The following steps also apply to a **non-standard configuration equipped with accessories but no additional equipment**. Refer to fig. 1.27, fig. 1.28 and fig. 1.29 on p. 22, for details about the restrictions and allowances for a configuration. Refer also to p. 17 of this section for more information about standard and non standard configurations.

- 1- Prepare the installation as described in the safety guidelines for dismantling an M2 Series installation, on p. 32.
- 2- If the installation is equipped with weather protection, remove all tarps and shields before the start of dismantling operations.
- 3- It is important to note that any installed **monorail must not be used** during dismantling operations.
- 4- It is important to consider that any installed hoist can **only** be used to unload mast sections and cannot be used above the last tie level installed.
- 5- Bring the motorized units to the top of the work, verifying mast bolts and mast ties on each mast on the way up. Make sure that all mast bolts are tightened at the appropriate torque and that all mast ties are properly tied to the face of the work.
- 6- Lower the motorized units linked by a bearing bridge until the units are two rungs (20" or 50 cm) above base level, removing mast sections and mast ties on the way down. To make sure that the installation remains stable, remove mast sections alternately – one on one motorized unit, then one on the other. Refer to p. 75 of the *Masts and Mast Ties* section for instructions on how to remove and transport mast sections. Refer to p. 75 of the *Masts and Mast Ties* section for instructions on how to remove mast ties. **Mast sections should be stored horizontally and distributed equally on the motorized units to ensure good balance.**

Setup and configurations

Dismantling an installation



Dismantling a standard multiple units installation – with mast ties

- 7- Make sure to avoid overloading the motorized units. On higher installations, it may be required to use a crane to remove mast sections from the motorized units to avoid any overloads. Refer to the *Load Capacities* section on p. 80 of for more information about loads allowed on a motorized unit.
- 8- Once at base level, remove any installed accessory such as hoist, monorail and weather protection structure.
- 9- Remove all loads from the platform and make all workers step down.
- 10- Remove all planking, push in all outriggers and secure in place. Remove and store all guardrails. For instructions on the removal and storage of guardrails, refer to p. 118 of the *Transport, Storage and Maintenance* section.
- 11- First remove any installed cantilever bridge, then dismantle the bearing bridge structure as described in the instructions on p. 48 of the *Bridges* section.
- 12- If any of the units is to be stored for any significant length of time, refer to p. 118 of the *Transport, Storage and Maintenance* section for instructions on how to properly store an M2 Series motorized unit.



WARNING

Tarps and shields used for weather protection **must be removed before the start of dismantling operations**. Any installed monorail must not be used during dismantling operations.

Dismantling a single unit installation with mast ties



The following dismantling steps can be used for a **non-standard configuration with additional equipment but no accessories other than a hoist**. Refer to fig. 1.27, fig. 1.28 and fig. 1.29 on p. 22, for details about the restrictions and allowances for a configuration. Refer also to p. 17 of this section for more information about standard and non standard configurations.

- 1- Prepare the installation as described in the safety guidelines for dismantling an M2 Series installation, on p. 32.
- 2- It is important to consider that any installed hoist can **only** be used to unload mast sections and cannot be used above the last tie level installed.
- 3- Lower the motorized unit to base level and remove all cantilever bridges and any installed equipment such as a forward extension, swivel bridge or planking wider than four planks.
- 4- Bring the motorized unit to the top of the work, verifying mast bolts and mast ties on each mast on the way up. Make sure that all mast bolts are tightened at the appropriate torque and that all mast ties are properly tied to the face of the work.
- 5- Lower the motorized unit to base level again, removing all mast sections and mast ties on the way down. Refer to p. 75 of the *Masts and Mast Ties* section for instructions on how to remove and transport mast sections. Refer to p. 75 of the *Mast and Mast Ties* section for instructions on how to remove mast ties. **Mast sections should be stored horizontally and distributed equally on the motorized unit to ensure good balance.**



WARNING

During dismantling, a hoist can **only** be used to unload mast sections and cannot be used above the last tie level installed. .

Setup and configurations

Dismantling an installation

Dismantling a standard single unit installation – with mast ties

- 
- 6- Make sure to avoid overloading the motorized unit. On higher installations, it may be required to use a crane to remove mast sections from the motorized unit to avoid any overloads. Refer to the *Load Capacities* section on p. 80 of for more information about loads allowed on a motorized unit.
 - 7- Once at base level, remove the hoist, if installed.
 - 8- Remove all loads from the platform and make all workers step down.
 - 9- Remove all planking, push in all outriggers and secure in place. Remove and store all guardrails. For instructions on the removal and storage of guardrails, refer to p. 118 of the *Transport, Storage and Maintenance* section.
 - 10- If the unit is to be stored for any significant length of time, refer to p. 118 of the *Transport, Storage and Maintenance* section for instructions on how to properly store an M2 Series motorized unit.

Dismantling a multiple units installation with mast ties



The following dismantling steps can be used for a **non-standard configuration with additional equipment but no accessories other than a hoist**. Refer to fig. 1.27, fig. 1.28 and fig. 1.29 on p. 22, for details about the restrictions and allowances for a configuration. Refer also to p. 17 of this section for more information about standard and non standard configurations.

- 
- 1- Prepare the installation as described in the safety guidelines for dismantling an M2 Series installation, on p. 32.
 - 2- It is important to consider that any installed hoist can **only** be used to unload mast sections and cannot be used above the last tie level installed.
 - 3- Lower the motorized units to base level and remove all cantilever bridges and any installed equipment such as a forward extension, swivel bridge or planking wider than four planks.
 - 4- Bring the motorized units to the top of the work, verifying mast bolts and mast ties on each mast on the way up. Make sure that all mast bolts are tightened at the appropriate torque and that all mast ties are properly tied to the face of the work.
 - 5- Lower the motorized units linked by a bearing bridge until the units are two rungs (20" or 50 cm) above base level, removing mast sections and mast ties on the way down. To make sure that the installation remains stable, remove mast sections alternately – one on one motorized unit, then one on the other. Refer to p. 75 of the *Masts and Mast Ties* section for instructions on how to remove and transport mast sections. Refer to p. 75 of the *Masts and Mast Ties* section for instructions on how to remove mast ties. **Mast sections should be stored horizontally and distributed equally on the motorized units to ensure good balance.**
 - 6- Make sure to avoid overloading the motorized units. On higher installations, it may be required to use a crane to remove mast sections from the motorized units to avoid any overloads. Refer to the *Load Capacities* section on p. 80 of for more information about loads allowed on a motorized unit.
 - 7- Once at base level, remove the hoist, if installed.
 - 8- Remove all loads from the platform and make all workers step down.
 - 9- Remove all planking, push in all outriggers and secure in place. Remove and store all guardrails. For instructions on the removal and storage of guardrails, refer to p. 118 of the *Transport, Storage and Maintenance* section.
 - 10- Dismantle the bearing bridge structure as described in the instructions on p. 48 of the *Bridges* section.
 - 11- If any of the units is to be stored for any significant length of time, refer to p. 118 of the *Transport, Storage and Maintenance* section for instructions on how to properly store an M2 Series motorized unit.

Setup and configurations

Lifting and moving a motorized unit or a setup

The lift and relocation of an M2 Series motorized unit or setup must be carried out with extreme care, using proper certified lifting equipment.

It is **mandatory** to refer to and comply with the capacities and limitations of the lifting device as specified by the manufacturer. It is important to consider that a 24' (7,3 m) motorized unit that must be lifted has a total weight of 7300 lb (3311 kg), while a 14' (4,3 m) motorized unit weighs a total of 6000 lb (2722 kg).

If required and if terrain is flat and solid, the M2 Series optional wheel set can be used to relocate an M2 Series motorized setup. For instructions on the installation and use of the wheel set, refer to p. 102 of the *Accessories* section.

Preparation

- 1- Before lifting and moving a motorized unit, a bearing bridge or a cantilever setup, make sure that all the workers have stepped down and that all tools, equipment and loads have been removed from the platform.
- 2- Remove all the planking, masts and mast ties **leaving only one mast section** in place. Make sure that all the guardrails and other components are secure, and that the mast locking bars are in place.
- 3- In reference to the plan/layout drawing, establish the position where the motorized unit or setup must be moved to and determine if there are obstacles.
- 4- Make sure that the lifting, transport and destination areas are clear of workers and equipment and that there are no obstacles.

	<p>WARNING</p> <p>An M2 Series motorized unit setup must only be lifted by the designated areas under the deck of the motorized unit.</p>
---	--

Lifting a motorized unit with a rough terrain forklift

This method must be used to lift and position a **motorized unit only**. It is **mandatory** to make sure that there aren't any bridges attached to the motorized unit before lifting and transporting it.

Lifting by the forklift tubes

- 1- Prepare the motorized unit as described in the preparation instructions above.
- 2- Insert the forks in the designated areas (forklift tubes) under the deck of the motorized unit (fig. 1.30).

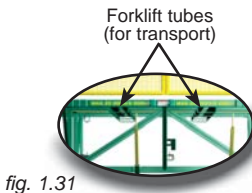

fig. 1.31

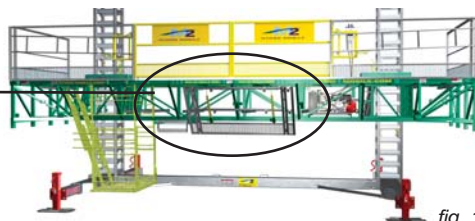

fig. 1.30

Setup and configurations

Lifting and moving a motorized unit or a setup

Lifting by the forklift tubes (cont'd)

- 3- Lift and position the motorized unit over its destination area. Before lowering the unit on the bearing surface, lower the base jacks by 4" to 5" (11 cm to 13 cm). Refer to p. 18 for more information about the installation and positioning of a motorized unit.



fig. 1.32



fig. 1.33

Lifting with chains, using a forklift

- 1- Prepare the motorized unit as described in the preparation instructions on p. 37.
- 2- Slip chains through the forklift tubes on the motorized unit. Secure the chains to the forks of a rough terrain forklift (fig. 1.34). Make sure to use an appropriate forklift attachment to secure the chains (shown in red, in fig. 1.34 and fig. 1.35).
- 3- Make sure that two workers, wearing proper personal protection (PPE), are standing on the ground using tag lines to help stabilize the structure during the lift, transport and landing of the motorized unit.
- 4- Lift and position the motorized unit over its destination area. Before lowering the unit on the bearing surface, lower the base jacks 4" to 5" (11 cm to 13 cm). Refer to p. 18 for more information about the installation and positioning of a motorized unit.

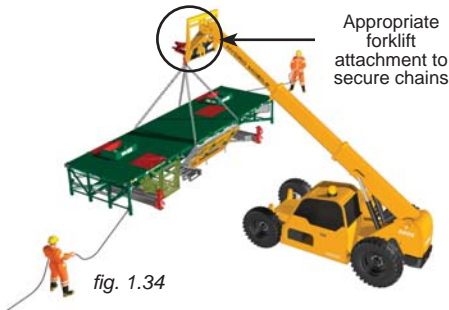

fig. 1.34

Appropriate forklift attachment to secure chains

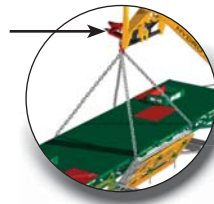

fig. 1.35

Lifting a motorized unit or a cantilever setup with a crane

This method can be used to lift and position a motorized unit or a motorized unit **cantilever** setup measuring a maximum of 64' (19,5 m).

Lifting with chains, using a crane

- 1- Prepare the motorized unit as described in the preparation instructions on p. 37.
- 2- Slip slings through the forklift tubes on the motorized unit (see fig. 1.34, p. 38). Secure the chains to the slings and to the crane.

Setup and configurations

Lifting and moving a motorized unit or a setup

Lifting with chains, using a crane (cont'd)

- 3- Make sure that two workers, wearing proper personal protection (PPE), are standing on the ground using tag lines to help stabilize the structure during the landing of the motorized unit.
- 4- Lift and position the motorized unit or the cantilever setup over its destination area. Before lowering the unit on the bearing surface, lower the base jacks by 4" to 5" (11 cm to 13 cm). Refer to p. 18 for more information about the installation and positioning of a motorized unit.



fig. 1.36

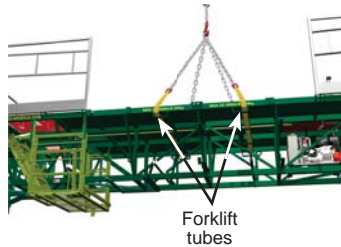

fig. 1.37

Lifting and moving a motorized unit with the wheel set

This method can be used to lift and position a **motorized unit** using the optional M2 Series wheel set under one end of the unit. It is important to note that **masts** must have a **maximum height** of 10' (3 m) when using this procedure to move a motorized unit.

- 1- Carefully follow the steps described in the preparation instructions on p. 37. Make sure to select a sling, a cable or chains that can lift a **minimum weight** of 7000 lb (3175 kg).
- 2- Install the optional wheel set under one end of the motorized unit (fig. 1.38). For instructions on the installation and use of a wheel set, refer to p. 102 of the *Accessories* section.



fig. 1.38

- 3- Slide chains, a cable or a sling through the other end of the motorized unit and secure it crosswise to the forks of a rough terrain forklift. Make sure to use an appropriate forklift attachment to secure the sling (shown in red, in fig. 1.34 and fig. 1.35, p. 38).
- 4- Move the motorized unit to its destination area. Position the motorized unit. Before lowering the unit on the bearing surface, lower the base jacks by 4" to 5" (11 cm to 13 cm). Refer to p. 18 for more information about the installation and positioning of a motorized unit.

Setup and configurations

Lifting and moving a motorized unit or a setup

Lifting and moving a cantilever setup with the wheel set

This method can be used to lift and position a **cantilever** setup measuring a maximum of 64' (19,7 m) using the optional M2 Series wheel set at one end of the structure. It is important to note that **masts** must have a **maximum height** of 10' (3 m) when using this procedure to move a cantilever setup.

- 1- Carefully follow the steps described in the preparation instructions on p. 37. Make sure to select a sling, a cable or chains that can lift a **minimum weight** of 7000 lb (3175 kg).
- 2- Install the optional wheel set under the second vertical member of the bridge in the cantilever structure closest to the motorized unit (fig. 1.39 and fig. 1.40). For more information about the installation and use of a wheel set, refer to p. 102 of the *Accessories* section.



fig. 1.39



fig. 1.40

- 3- Slide chains, a cable or a sling through the last bridge installed at the other end of the setup and secure it crosswise to the forks of a rough terrain forklift. Make sure to use an appropriate forklift attachment to secure the sling (shown in red, in fig. 1.34 and fig. 1.35, p. 38).
- 4- Move the cantilever setup to its destination area. Position the motorized unit. Before lowering the unit on the bearing surface, lower base jacks by 4" to 5" (11 cm to 13 cm). Refer to p. 18 for more information about the installation and positioning of a motorized unit.



WARNING

Installing the wheel set under an area of the bridge without a vertical member will damage the bridge structure permanently.

Lifting and moving a bearing bridge structure with the wheel set

This method can be used to lift and position a **bearing bridge** structure measuring a maximum of 62' (18,9 m) using the optional M2 Series wheel set at one end of the structure.

- 1- Carefully follow the steps described in the preparation instructions on p. 37. Make sure to select a sling that can lift a **minimum weight** of 4500 lb (2041 kg).
- 2- Install the optional wheel set under the second vertical member of the first bridge at one end of the bearing bridge structure. For more information about the installation and use of a wheel set, refer to p. 102 of the *Accessories* section.



fig. 1.41

- 3- Slide chains, a cable or a sling through the last bridge installed at the other end of the structure and secure it crosswise to the forks of a rough terrain forklift. Make sure to use an appropriate forklift attachment to secure the sling (shown in red, in fig. 1.36).
- 4- Move the bearing bridge structure to its destination area. Refer to p. 18 for more information about the installation and positioning of multiple units linked by a bearing bridge.

Safety Devices

Safety Hooks System

Activation of the safety hooks system

- 1- In the event of an activation of the safety hooks system, the qualified operator must contact the distributor/service center or the Hydro Mobile technical support team.
- 2- All precautions must be immediately taken to ensure the safe return of all workers to the nearest safe evacuation point according to the evacuation plan (see step 21 on p. 6 of the *Performance and Safety Rules* section). **The motorized unit must be immediately put out of service.**
- 3- Make sure the safety hooks system is properly engaged (fig. 2.2).

The following steps must be performed by a qualified technician. For the definition of a qualified technician, refer to p. 5 of the *Performance and Safety Rules* section.

- 4- Determine what caused the activation of the safety hooks system.
- 5- Remove as much load from the motorized unit and the bridges as possible.
- 6- Perform a thorough inspection of the entire installation from base level to the top of the work, including structures, mast ties, anchoring system for any damages possibly caused by the incident.
- 7- Take the necessary actions to have the motorized unit repaired properly, according to Hydro Mobile standards. It is **mandatory** to visually inspect the safety hooks and replace the hook that was activated. Any **triggered** safety hook **cannot be used a second time and must be replaced immediately** before operating the motorized unit. It is **mandatory** to also replace the bolt and nut of the safety hook.
- 8- Once all the mandatory corrective actions described in the previous steps have been carried out, make sure that the cylinder hook and the secondary hook are properly engaged on a mast rung on each mast (fig. 4.23, p. 66) and **carefully lower** the motorized unit to base level.
- 9- In all cases, the motorized unit must be thoroughly inspected and all the necessary repairs must be made according to Hydro Mobile's recommendations before resuming normal operation of the motorized unit.

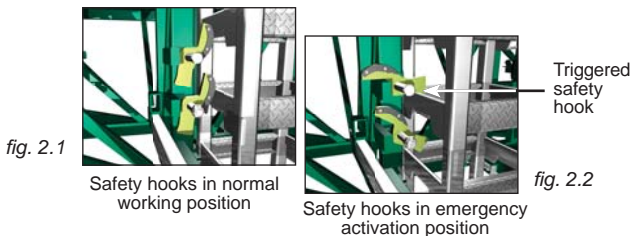

Safety Devices

Fall Protection Equipment (not provided)

The use of fall protection equipment is **mandatory** for all workers on an M2 Series motorized unit setup whenever a fall hazard is present. It is recommended to use a combination of full body harness and a shock-absorbing lanyard. It is mandatory to use certified fall protection equipment that is clean and in good working condition. Fall protection equipment should be inspected before each use and be replaced if found to be defective. Refer to the manufacturer's recommendations for more information about the use and care of the selected equipment. Refer also to local regulations for more information about fall protection equipment requirements.

Safety Devices

Fall Protection Equipment (not provided)

When climbing or descending the mast

The use of fall protection equipment is **recommended** when climbing or descending the mast when the height of lift is over 10' (3 m) above base level and is **mandatory** for climbing or descending the mast when the height of lift is between 30' and 69' (9 m and 21 m). It is not recommended to climb or descend the mast when the setup is at heights over 69' (21 m) because of the time and effort required to reach such heights. The use of alternate equipment compliant with local regulations, such as a rapid mast climber, a transport platform system, or a conventional scaffold stair system will prove to be more efficient. Refer to local regulations for more information.

- 1- Attach a rope to a self-retracting lifeline hook for easy retrieval from base level.
- 2- Using the designated tie point (fig. 2.5) on the motorized unit, secure the fall protection equipment. Tie points are designed to resist to a maximum arrest force of 5000 lb (2268 kg) and can be used by workers to tie themselves to the unit (not more than one worker per tie point).
- 3- Attach the body harness to the self-retracting lifeline before climbing or descending the mast.



fig. 2.3
Self-retracting lifeline



fig. 2.4

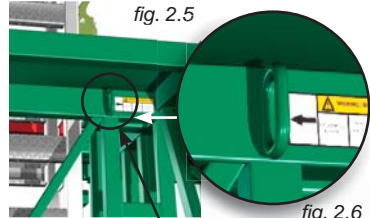

fig. 2.5
Tie a lifeline with a rope grab or a self-retracting lifeline to the designated tie point under the motorized unit

fig. 2.9



fig. 2.7
Tie point located at the front of the motorized unit



fig. 2.8
Fall arrest bracket



Cross-arm anchorage strap (not manufactured by Hydro Mobile)

When moving planks

The use of fall protection equipment is **mandatory** when moving planks – for example, when moving planks away from in front of the masts to pass a tie level or to modify the planking configuration.

- 1- Using the designated tie point (fig. 2.5) on the motorized unit, an optional fall arrest bracket installed on two guardrails (fig. 2.8) or a cross-arm anchorage strap tied to two guardrails (fig. 2.9), secure the fall protection equipment. Tie points are designed to resist to a maximum arrest force of 5000 lb (2268 kg) and can be used by workers to tie themselves to the unit (not more than one worker per tie point).
- 2- Move planks in front of each mast to pass a tie level or modify the planking configuration.

Bridges

Bridges are assembled to the motorized unit to be used in cantilever or bearing bridge setups or as extensions to the platform work surface. Modular bridges have a dedicated wall side that must be installed towards the face of the work.

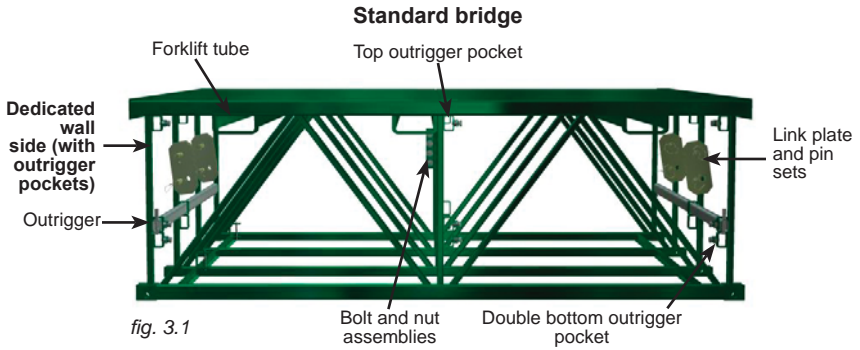

10' (3 m) modular bridge assembly shown in illustration

Bridge Types

10' (3 m) modular bridge

	
Size	120 1/8" x 87 13/16" x 39 3/16" (305 cm x 223 cm x 100 cm)
Weight	1360 lb (617 kg)
Guardrail	2x 60" (1,5 m) – 42 lb (19 kg) each
Outrigger	2x 2 1/2" x 1 1/2" x 3/16" x 72" long (6,4 cm x 3,8 cm x 0,5 cm x 183 cm)
Bolt and nut set	4x 1" x 2" long (GR5)
Link plates and pins set	4x standard link plates and pins sets

fig. 3.2

5' (1,5 m) modular bridge

	
Size	60 1/16" x 87 13/16" x 39 3/16" (153 cm x 223 cm x 100 cm)
Weight	795 lb (361 kg)
Guardrail	1x 60" (1,5 m) – 42 lb (19 kg)
Outrigger	1x 2 1/2" x 1 1/2" x 3/16" x 72" long (6,4 cm x 3,8 cm x 0,5 cm x 183 cm)
Bolt and nut set	4x 1" x 2" long (GR5)
Link plates and pins set	4x standard link plates and pins sets

fig. 3.3

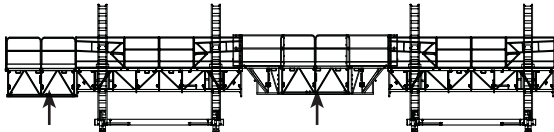
Bridge Types

6' (1,8 m) bearing bridge adapter

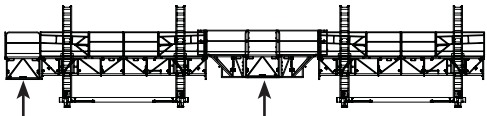
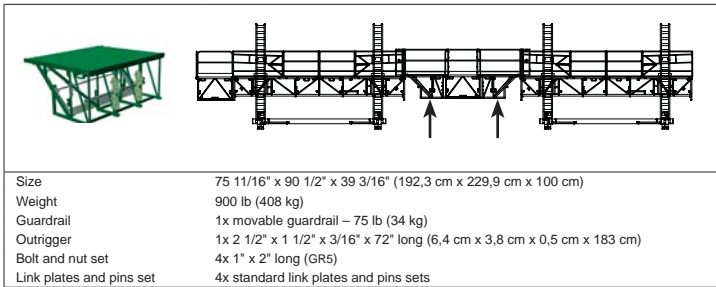

fig. 3.4

Multi-purpose insert bridge (MPI)

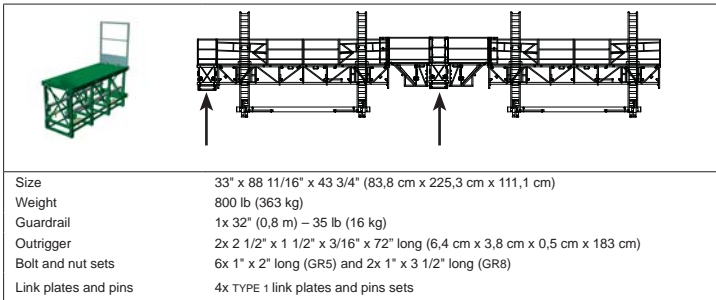

fig. 3.5

Bridge Setups

Cantilever Bridge

A cantilever bridge is the assembly of a bridge or an insert at one end of a motorized unit. To ensure stability, refer to the *Load Capacities* section on p. 80 for the number of bridges allowed in a cantilever configuration.

Installation

- 1- Make sure at least one mast section has been installed on top of each of the bottom mast sections welded on the base of the motorized unit.

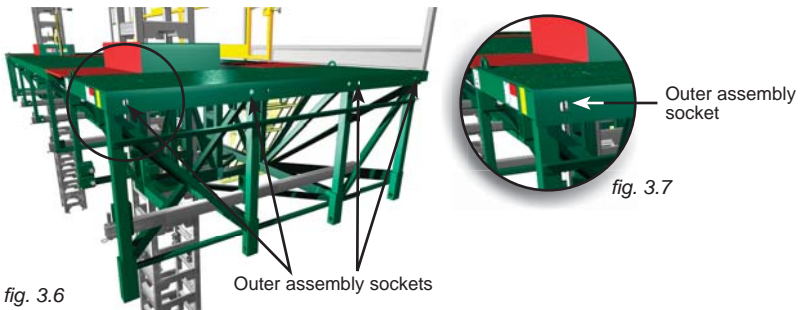

fig. 3.6

fig. 3.7

Bridge Setups

Cantilever Bridge

Installation (cont'd)

- 2- Raise the motorized unit by two mast rungs above base level. Refer to p. 65 of the *Power Pack and Operating Components* section for instructions on how to raise a motorized unit.
- 3- Using a rough terrain forklift or a crane, lift the bridge by the forklift tubes (fig. 1.4, p. 9) and align the top and bottom parts with the bridge or the motorized unit it must be attached to, according to the layout. For the installation of 10' (3 m) and 5' (1,5 m) modular bridges, make sure that the dedicated wall side (with outrigger pockets) is turned towards the face of the work (fig. 3.1, p. 43).
- 4- Assemble the top part of the bridge to the other bridge or to the motorized unit using four 1" x 2" long (GR5) bolt and nut assemblies through the **four outer assembly sockets** (fig. 3.6, p. 44) in the front and back. **Do not tighten the bolt and nut assemblies yet.**
- 5- Attach the bottom part of the bridge to the other bridge or to the motorized unit using link plates and pins sets (4) at the cantilever setting ("C" on fig. 3.8).

C = Cantilever setting

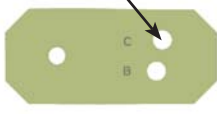

fig. 3.8

Link plate cantilever setting



fig. 3.9



fig. 3.10

- 6- **Tighten the nut and bolt assemblies** (4) at the top of the bridge to 100 lb-ft (136 N-m) of torque and install the appropriate guardrails. Refer to p. 91 of the *Accessories* section for more information on the installation and use of guardrails.
- 7- Repeat steps 3 to 6 to attach a second bridge assembly on the other side of the motorized unit.
- 8- Install as many additional bridges as required and allowed. It is important to install each bridge **alternately** on one side, then on the other side of the unit, to avoid throwing the structure out of balance. The number of bridges should be **equal on both sides** of a cantilever installation. Refer to the *Load Capacities* section on p. 80 for information on the number of bridges allowed in a cantilever bridge configuration.
- 9- If required, install optional cantilever outrigger supports. For more information about the installation and use of a cantilever outrigger support, refer to p. 100 of the *Accessories* section.



WARNING

In a cantilever configuration, it is important to install each bridge alternately on one side, then on the other side of the motorized unit to avoid throwing the structure out of balance. The number of bridges should be equal on both sides of a cantilever installation.

Bridge Setups

Bearing Bridge

(requires the use of two motorized units and two bearing bridge adapters – sold separately)

A bearing bridge is the assembly of a bridge structure that will be installed between two motorized units in a multiple units installation. The standard M2 Series bearing bridge structure will include two 6' (1,8 m) bearing bridge adapters at each end of the bearing bridge.

For the installation of a bearing bridge structure using a flush bearing bridge adapter, refer to p. 110 of the *Accessories* section.

Safety guidelines

- 1- In a bearing bridge setup (multiple units), it is mandatory to install any additional cantilever bridge **after** the bearing bridge structure has been installed to avoid throwing the structure off balance. Dismantle all the components of the structure in reverse order.
- 2- It is **mandatory** that two qualified operators handle all rise and descent operations and coordinate the motion of the two motorized units linked by a bearing bridge to ensure that the structure slope does not exceed 2° or $1" / 24"$ (2,5 cm / 61 cm). Refer to p. 5 of the *Motorized Unit* section for the definition of a qualified operator.
- 3- It is also important to make sure that the safety chains (two at each end) are properly hooked at all times (see step 10 of the installation instructions on p. 47).

Installation

- 1- Choose a clear, level surface close to the work area where the bridges can be temporarily set down to assemble the bearing bridge structure. To make sure that all the link plates are above the ground, set down wood cribbing or mast sections laid horizontally before lowering the bridges in place.
- 2- Using a rough terrain forklift or a crane, lift and lower a bridge on top of the wood cribbing or the laid down mast sections.
- 3- Lift another bridge and align it carefully with the bridge it must be attached to. Assemble the top part of the bridge to the other bridge using four 1" x 2" long (GR5) bolt and nut assemblies through the **four outer assembly sockets** (fig. 3.6, p. 44) in the front and back. **Do not tighten the bolt and nut assemblies yet.**
- 4- Attach the bottom part of the bridge to the other bridge using link plates and pins sets (4) at the bearing setting (fig. 3.11).
- 5- **Tighten the nut and bolt assemblies** (4) at the top of the bridges to 100 lb-ft (136 N-m) of torque.

Link plate bearing setting

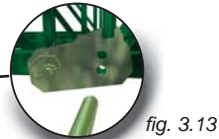
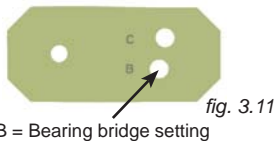

- 6- Repeat steps 2 through 5 to assemble the complete bearing bridge structure using as many bridges as is required and allowed, making sure that a 6' (1,8 m) bearing bridge adapter is installed at each end of the bearing bridge. For more information on the number of bridges allowed in a setup, refer to the *Load Capacities* section on p. 80.
- 7- Measure the length of the bearing bridge structure and subtract $9" \times 2 = 18"$ ($23 \text{ cm} \times 2 = 46 \text{ cm}$) to obtain the ideal distance between the two motorized units.
- 8- Make sure that the ideal distance is kept between the two motorized units installed in order to have an overlap of 9" (23 cm) at each end of the bearing bridge structure.



WARNING

When raising or lowering motorized units linked by a bearing bridge, any bridge slope should not exceed a maximum of 2° or $1" / 24"$ (2,5 cm / 61 cm).

Bridge Setups

Bearing Bridge

(requires the use of two motorized units and two bearing bridge adapters – sold separately)

Installation (cont'd)

- Using a rough terrain forklift or a crane, lift the bearing bridge assembly from the ground and lower it down onto the two motorized units making sure the overlap is between 6" and 12" (15 and 30 cm) at each end. If the bearing bridge structure must be installed off center, make sure it not offset by more than 12" (30,5 cm) at either end.

Bearing bridge structure offset at either end

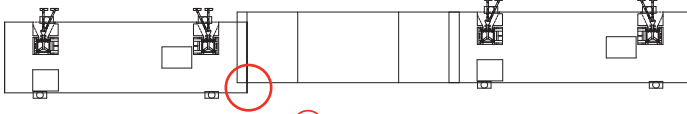

fig. 3.17

○ = Maximum offset of 12" (30,5 cm)

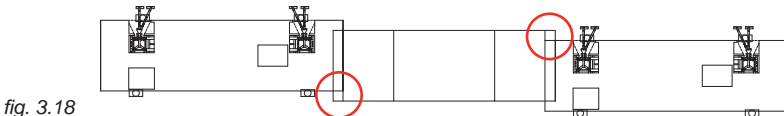

fig. 3.18

Bearing bridge structure offset at both ends



WARNING

When installing a bearing bridge structure off center between two motorized units, it is important to make sure that the structure is not offset by more than 12" (30,5 cm) at either end.

Bearing bridge safety chains

- Using the shackle, tie the bridge safety chain to the safety loop on the motorized unit, making sure the slack does not exceed 1" (2,5 cm) when pulling it tightly towards the motorized unit (fig. 3.15). Perform this step for each safety chain at both ends of the bearing bridge structure (four in total).

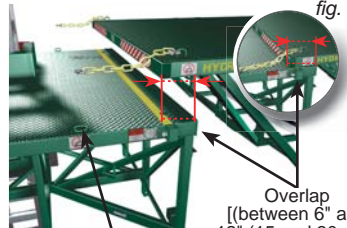

fig. 3.15

fig. 3.14

Anchor point for safety chain

Overlap [(between 6" and 12" (15 and 30 cm)]



WARNING

It is important to make sure that all safety chains are properly hooked at all times.

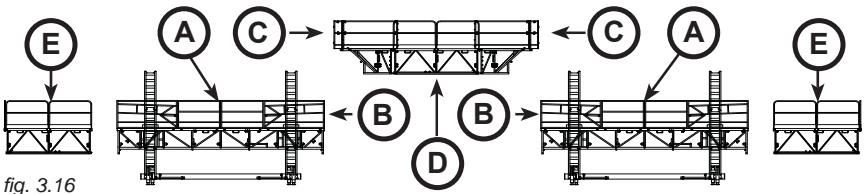

fig. 3.16



WARNING

To ensure safe and proper operation, Hydro Mobile recommends that **two persons** be on hand to perform maneuvers for **each motorized unit in a setup** and that **at least one of those two persons is a qualified operator** for an M2 Series motorized unit and its accessories.

Bridge Setups

Bearing Bridge

(requires the use of two motorized units and two bearing bridge adapters – sold separately)

Dismantling a bearing bridge structure

SAFETY comes first. It is essential that **all dismantling operations** of a bearing bridge be carried out with the same care and precaution taken during the installation. It is mandatory to refer to the safety guidelines and to select the dismantling method appropriate to the installation, starting on p. 32 of the *Motorized Unit* section. The following dismantling steps are for the bearing bridge structure only.

- 1- Follow the dismantling steps appropriate to the installation.
- 2- Unhook the bearing bridge safety chains (four in total).
- 3- To make sure that all the link plates are above the ground, set down wood cribbing or mast sections laid horizontally before lowering the bridges in place.
- 4- Using a rough terrain forklift or a crane, slightly raise the bearing bridge and lower it on wood cribbing or mast sections laid horizontally to facilitate disassembly.

Multi Purpose Insert Bridge (MPI)

Designed to work with both 14' (4,3 m) and 24' (7,3 m) M2 Series motorized units, multi-purpose insert (MPI) bridges can be assembled to create back or forward extensions, as well as regular cantilever bridges. Multiple cantilever, lateral cantilever and narrow bearing bridge setups can also be assembled using optional link plates.

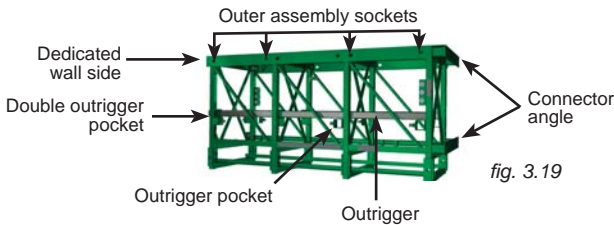

fig. 3.19

Bridge Link Plates

TYPE 1 (factory default)



fig. 3.20

Part number	11011500-1-10000-4
Distance A	7 5/8" (19,4 cm)
Distance B	5 1/2" (14 cm)

TYPE 2 (optional)



fig. 3.21

Part number	11011300-1-10000-4
Distance A	6" (15,2 cm)

TYPE 3 (optional)



fig. 3.22

Part number	11011600-1-10000-4
Distance A	4 1/8" (10,5 cm)
Distance B	8 1/4" (21 cm)

TYPE 4 (optional)



fig. 3.23

Part number	11011700-1-10000-4
Distance A	6 1/2" (16,5 cm)

Bridge Setups

Multi Purpose Insert Bridge (MPI)

As Forward / Back Extension Bridge

Installation as a forward extension

- 1- Using a rough terrain forklift or a crane, lift the first multi purpose insert bridge (MPI) and align the top and bottom parts with the motorized unit, as shown in fig. 3.24. Make sure that the dedicated wall side (fig. 3.19) is turned towards the face of the work.
- 2- Assemble the top part of the MPI bridge to the motorized unit using four 1" x 2" long (GR5) bolt and nut assemblies through the outer assembly sockets (fig. 3.19, p. 48). **Do not tighten the bolt and nut assemblies yet.**
- 3- Using four sets of bridge link plates and pins (TYPE 1 link plates, fig. 3.27), attach the bottom part of the bridge to the motorized unit (fig. 3.24, p. 49).
- 4- **Tighten the nut and bolt assemblies (4)** at the top of the bridge to 100 lb-ft (136 N-m) of torque.
- 5- Lift and align the top and bottom parts of the second MPI bridge with the first MPI bridge installed. Assemble the **top part** of the bridges using two 1" x 3 1/2" long (GR8) bolt assemblies and the **bottom part** of the bridges using two 1" x 2" long (GR5) bolt and nut assemblies.
- 6- **Tighten all the nut and bolt assemblies (4)** at the top and bottom of the bridges to 100 lb-ft (136 N-m) of torque.
- 7- Repeat steps 5 and 6 to continue installing as many MPI bridges as is required and allowed. For more information on the types and number of bridges allowed in a configuration, refer to the *Load Capacities* section on p. 80.
- 8- If required, repeat steps 5 and 6 to install the MPI bridge in the back of the setup where a counterweight must be applied (fig. 3.26). Refer to the *Load Capacities* section on p. 80 for more information about counterweight requirements in a forward / back extension configuration.
- 9- Once the installation is complete, install the appropriate guardrails. Refer to p. 91 of the *Accessories* section for more information on the installation and use of guardrails.

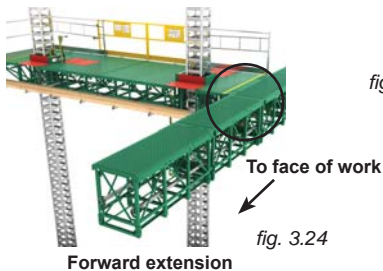

Forward extension

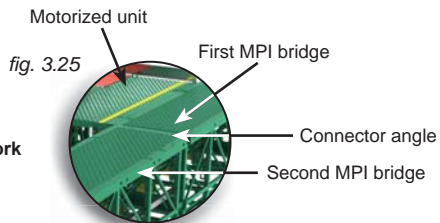
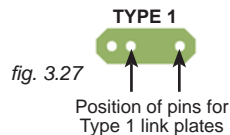

fig. 3.26

Required link plates



Installation as a back extension

- 1- Follow steps 1 through 8 of the installation procedure for a forward extension. Make sure to install the bridges with the dedicated wall side turned **away** from the face of the work.
- 2- Once the installation is complete, install the appropriate guardrails. Refer to p. 91 of the *Accessories* section for more information on the installation and use of guardrails.

Bridge Setups

Multi Purpose Insert Bridge (MPI)

As Cantilever Bridge (requires the use of optional cantilever link plates)

Installation

- 1- Using a rough terrain forklift or a crane, lift the first multi purpose insert bridge (MPI) (fig. 3.30) and align the top and bottom parts with the motorized unit. Make sure that the dedicated wall side (fig. 3.19, p. 48) is turned **towards** the face of the work.
- 2- Assemble the top part of the MPI bridge to the motorized unit using four 1" x 2" long (GR5) bolt and nut assemblies through the outer assembly sockets (fig. 3.19, p. 48). **Do not tighten the bolt and nut assemblies yet.**
- 3- Using four sets of bridge link plates and pins (TYPE 1 link plates, fig. 3.29), attach the bottom part of the bridge to the motorized unit (fig. 3.31).
- 4- **Tighten the nut and bolt assemblies (4)** at the top of the bridge to 100 lb-ft (136 N-m) of torque.
- 5- Lift and align the top and bottom parts of the second MPI bridge with the first MPI bridge installed. Assemble the top part of the bridges as described in step 2.

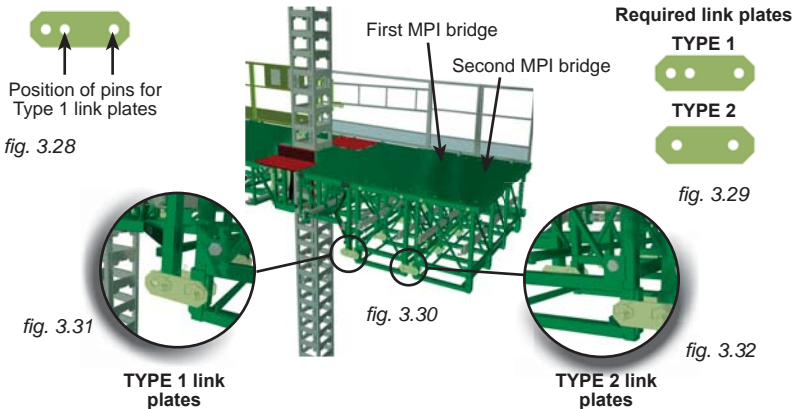

- 6- Using four sets of bridge link plates and pins (TYPE 2 link plates, fig. 3.29), attach the bottom part of the bridge to the other bridge installed. It is important to note that TYPE 2 link plates must be used to attach the bottom part of each subsequent MPI bridge installed (fig. 3.32). **Tighten all bolt assemblies** to 100 lb-ft (136 N-m) of torque.
- 7- Repeat steps 5 and 6 to continue installing as many MPI bridges as is required and allowed. For more information on the types and number of bridges allowed in a configuration, refer to the *Load Capacities* section on p. 80.
- 8- Once the installation is complete, install the appropriate guardrails. Refer to p. 91 of the *Accessories* section for more information on the installation and use of guardrails.

As Lateral Cantilever Bridge (requires the use of optional cantilever link plates)

Installation

- 1- Using a rough terrain forklift or a crane, lift the first multi purpose insert bridge (MPI) and align the top and bottom parts with the motorized unit, as shown in fig. 3.35, p. 51. Make sure that the connector angles (fig. 3.19, p. 48) are turned **towards** the motorized unit.

Bridge Setups
Multi Purpose Insert Bridge (MPI)
As Lateral Cantilever Bridge
 (requires the use of optional cantilever link plates)

Installation (cont'd)

- 2- Assemble the top part of the MPI bridge to the motorized unit using two 1" x 2" long (GR5) bolt and nut assemblies. **Do not tighten the bolt and nut assemblies yet.**
- 3- Using two bridge link plates and pins assemblies (TYPE 1 link plates, fig. 3.34), attach the bottom part of the bridge to the motorized unit (fig. 3.36).
- 4- **Tighten the nut and bolt assemblies (2)** at the top of the bridge to 100 lb-ft (136 N-m) of torque.
- 5- Lift the second MPI bridge and align the top and bottom parts with the first MPI bridge installed.
- 6- Assemble the **top part** of the bridges using two 1" x 3 1/2" long (GR8) bolt assemblies and the **bottom part** of the bridges using two 1" x 2" long (GR5) bolt and nut assemblies (fig. 3.37). It is important to note that a **maximum of two bridges** can be installed in a lateral cantilever configuration. For more information on the types and number of bridges allowed in a configuration, refer to the *Load Capacities* section on p. 80.

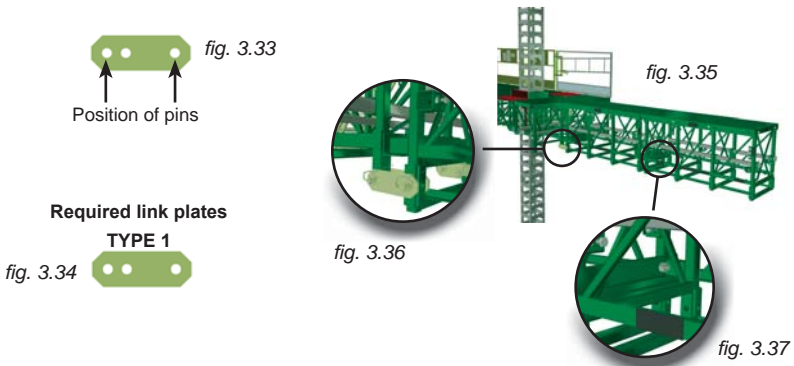

- 7- **Tighten all the nut and bolt assemblies (4)** at the top and bottom of the bridge to 100 lb-ft (136 N-m) of torque.
- 8- Once the installation is complete, install the appropriate guardrails. Refer to p. 91 of the *Accessories* section for more information on the installation and use of guardrails.

As Narrow Bearing Bridge
 (requires the use of optional bearing link plates)

Installation

- 1- Choose a clear, level surface close to the work area where the bridges can be temporarily set down to assemble the bearing bridge structure. To make sure that all the bridge link plates are above the ground, set down wood cribbing or mast sections laid horizontally before lowering the bridges in place.
- 2- Using a rough terrain forklift or a crane, lift the first multi purpose insert bridge (MPI) and align the connector angle (fig. 3.19, p. 48) with the 6' (1,8 m) bearing bridge adapter it must be attached to.
- 3- Assemble the top part of the two bridges using two 1" x 2" long (GR5) bolt and nut assemblies. **Do not tighten the bolt and nut assemblies yet.**
- 4- Using two bridge link plates and pins assemblies (TYPE 3 link plates, fig. 3.39, p. 52), attach the bottom part of the MPI bridge to the 6' (1,8 m) bridge as shown in "A", fig. 3.42, p. 52.

Bridge Setups Multi Purpose Insert Bridge (MPI)

As Narrow Bearing Bridge (requires the use of optional bearing link plates)

Installation (cont'd)

- 5- **Tighten the nut and bolt assemblies (2)** at the top of the bridges to 100 lb-ft (136 N-m) of torque.
- 6- Lift the second MPI bridge and align the connector angle with the first MPI bridge installed.
- 7- Assemble the top part of the bridges using two 1" x 3 1/2" long (GR8) bolt and nut assemblies. **Do not tighten the bolt and nut assemblies yet.**
- 8- Using two bridge link plates and pins assemblies (TYPE 4 link plates, fig. 3.39), attach the bottom part of the bridges as shown in "B", fig. 3.43.
- 9- **Tighten the nut and bolt assemblies (2)** at the top part of the bridges to 100 lb-ft (136 N-m) of torque.
- 10- Repeat steps 6 to 9 to continue installing as many MPI bridges as is required and allowed. For more information on the types and number of bridges allowed in a configuration, refer to the *Load Capacities* section on p. 80.
- 11- Lift and align the 6' (1.8 m) bearing bridge adapter with the last MPI bridge installed. Assemble the top part of the bridge to the last MPI bridge as described in step 7.
- 12- Using two bridge link plates and pins sets (TYPE 3 link plates, fig. 3.39), attach the bottom part of the bridge to the last MPI bridge as shown in "C", in fig. 3.44. **Tighten the nut and bolt assemblies** to 100 lb-ft (136 N-m) of torque.
- 13- Using a rough terrain forklift or a crane, lift the bearing bridge structure and install it between two motorized units. Refer to p. 46 of this section for more information about the installation of a bearing bridge structure.
- 14- Once the installation is complete, install the appropriate guardrails. Refer to p. 91 of the *Accessories* section for more information on the installation and use of guardrails.

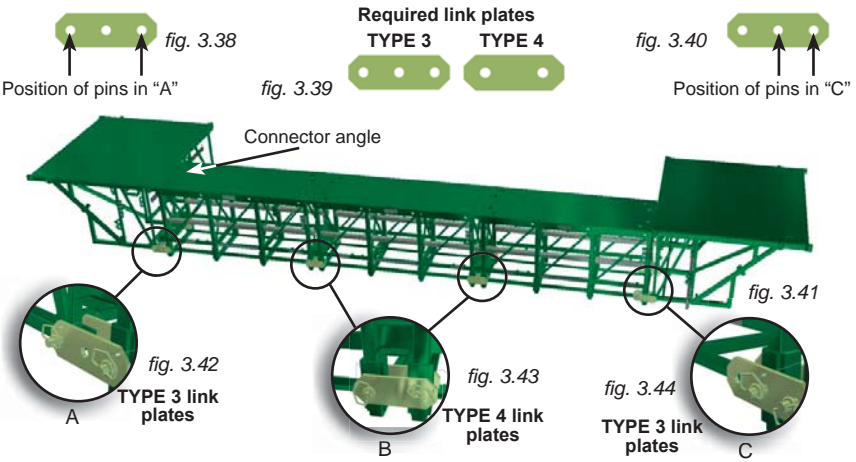

WARNING
Multi purpose insert (MPI) bridges bearing a serial number prior to EXT02-134 require the use of an optional reinforcing kit when used in bearing bridge configurations.

Bridge Setups

Alternate Bridge Configurations

Alternate bridge configurations can be used with M2 Series motorized units to adapt setups to various structures (curvatures, recesses, columns, etc.).

Angled Bearing Bridge Setup (requires the use of one or two optional MPI bridges)

An angled bearing bridge setup is the overlapping of a bearing bridge structure at an angle on one or both motorized units of a multiple units installation (fig. 3.45). It is important to note that flush bearing bridge adapters cannot be used when a bearing bridge must be overlapped at an angle.

The following installation steps must be carried out as part of a selected method of installation appropriate for the configuration. For more information about setups and configurations, refer to p. 18 of the *Motorized Unit* section.

Positioning the first motorized

- 1- Prepare and position the first motorized unit and the area where the setup will be installed as described in the instructions steps included in the method of installation appropriate for the configuration. For more information about methods of installation, refer to p. 18 of the *Motorized Unit* section.

Installation of a multi purpose insert bridge (MPI)

- 2- Install a cantilever multi purpose insert bridge (MPI) to support the angled bearing bridge structure. Refer to steps 1 through 4 of the installation instructions for a cantilever multi purpose insert bridge (MPI) on p. 50 of this section.

Installation of the bearing bridge structure

- 3- Assemble the bearing bridge structure as required and allowed. Refer to steps 1 through 6 of the installation instructions for a bearing bridge structure, on p. 46 of the *Bridges* section.
- 4- Carefully lift and lower one end of the bearing bridge structure at an angle on top of the MPI attached to the motorized unit installed. **Still holding the bearing bridge structure**, make sure the distance between the corners of the bearing bridge structure and the corresponding support points on the surface on which it is overlapped (shown in yellow in fig. 3.46) is not more than 6" (15 cm) at each corner. Adjust the alignment of the structure, as necessary. Make sure the bearing bridge structure is supported at the end where no motorized unit is yet installed.

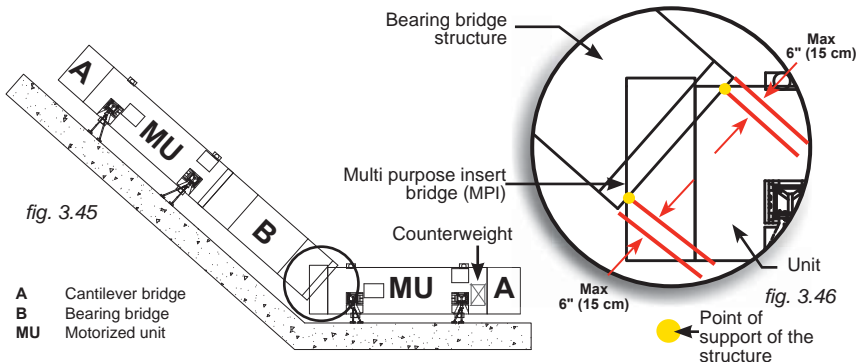

Positioning the second motorized unit

- 5- Prepare and position the second motorized unit and the area where the setup will be installed as described in the instructions steps included in the method of installation appropriate for the configuration. For more information about methods of installation, refer to p. 18 of the *Motorized Unit* section.

Bridge Setups

Alternate Bridge Configurations

Angled Bearing Bridge Setup (requires the use of one or two optional MPI bridges)

Installation of a multi purpose insert bridge (MPI)

- 6- If required, install a cantilever multi purpose insert bridge (MPI) on the second motorized unit to support the bearing bridge structure at an angle. Refer to steps 1 through 4 of the installation instructions for a cantilever multi purpose insert bridge (MPI) on p. 50 of this section.

Complete the installation of the bearing bridge structure

- 7- Carefully lower the bearing bridge structure on the motorized unit or the MPI installed, making sure the overlap is appropriate. Refer to step 4 of these installation instructions if this end of the structure is also at an angle or to the regular bearing bridge installation procedure, on p. 46 of this section.
- 8- Make sure all safety chains are properly installed and secured.
- 9- Proceed with the installation steps as described in the method of installation appropriate for the configuration. For more information about methods of installation, refer to p. 18 of the *Motorized Unit* section.
- 10- Once the bearing bridge structure and the cantilever bridges are installed, apply the appropriate counterweight on the unit supporting the angled bearing bridge structure. The counterweight must be set between the mast section and the edge of the motorized unit (see fig. 3.46). Refer to p. 89 and p. 90 of the *Load Capacities* section for counterweight requirements and load capacities for an angled bearing bridge configuration.

Inside / Outside Corner Bearing Bridge Setup (requires the use of an optional 6' (1,8 m) bridge)

An inside or outside corner bearing bridge setup is the installation of a bearing bridge structure between two motorized units installed at a 90° angle from one another. It is important to note that flush bearing bridge adapters cannot be used when a bearing bridge is used in a corner configuration.

The following installation steps must be carried out as part of a selected method of installation appropriate for the configuration. For more information about setups and configurations, refer to p. 18 of the *Motorized Unit* section.

Positioning the motorized units

- 1- Prepare and position the first motorized unit and the area where the setup will be installed as described in the instructions steps included in the method of installation appropriate for the configuration. For more information about methods of installation, refer to p. 18 of the *Motorized Unit* section.
- 2- Determine the position of the second motorized unit while making sure that the ideal distance is kept between the two motorized units. Refer to the installation instructions for a bearing bridge structure, on p. 46 of the *Bridges* section.

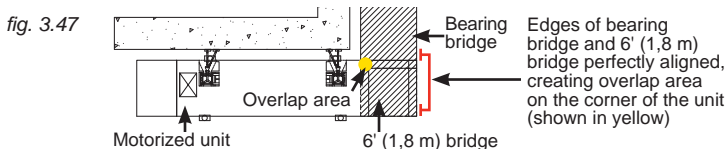

WARNING

During the pre-installation of an angled or corner bearing bridge setup, it is important to make sure that any required counterweight is in place **before** the start of any pre-installation operation.

Bridge Setups

Alternate Bridge Configurations

Inside / Outside Corner Bearing Bridge Setup (requires the use of an optional 6' (1,8 m) bridge)

Installation of the 6' (1,8 m) bridge

- 3- On the corner end of the motorized unit where the bearing bridge will be overlapped, attach a 6' (1,8 m) bridge **to the motorized unit** to provide support for the bearing bridge structure (see "C" in fig. 3.48 and fig. 3.49). Refer to the installation instructions for a cantilever bridge on p. 44 of this section.

Installation of a cantilever bridge

- 4- Install a cantilever bridge (see "D" in fig. 3.48 and fig. 3.49) on the "corner" motorized unit on the side opposite to where the bearing bridge structure will be installed.

Complete the installation of the bearing bridge structure

- 5- Carefully lower the bearing bridge structure on the corner motorized unit and on the 6' (1,8 m) bridge installed on the other unit ("C" in fig. 3.48 and fig. 3.49, making sure the overlap is appropriate at both ends. The edge of the bearing bridge must be in line with the edge of the 6' (1,8 m) bridge on the "corner" unit, creating a 12" (30,5 cm) overlap on the corner of unit (see fig. 3.47, p. 54).
- 6- Make sure all safety chains are properly installed and secured.
- 7- Once the bearing bridge structure and the cantilever bridges are installed, apply the appropriate counterweight on the unit supporting the angled bearing bridge structure. The counterweight must be set between the mast section and the edge of the motorized unit (see "CW" in fig. 3.48 and fig. 3.49). Refer to p. 89 and p. 90 of the *Load Capacities* section for counterweight requirements and load capacities for an inside or outside corner bearing bridge configuration.
- 8- Proceed with the installation steps as described in the method of installation appropriate for the configuration. For more information about methods of installation, refer to p. 18 of the *Motorized Unit* section.

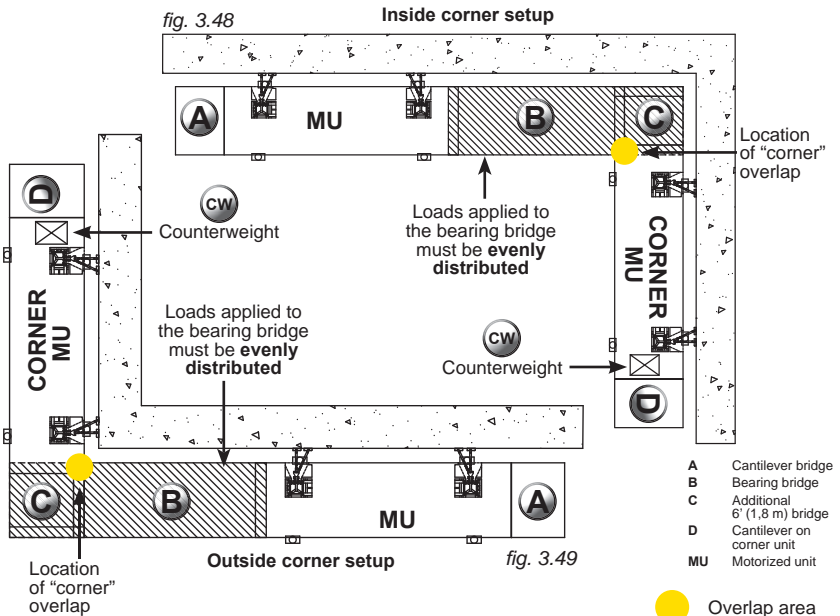

Bridge Setups Swivel Bridge (optional)

Installed directly on the motorized unit, the optional swivel bridge allows creating front 0° to 45° configurations, as well as front corner (90°) configurations for **cantilever installations**. The swivel bridge **cannot be used to achieve back configurations and cannot be installed on the bearing bridge side of a multiple units configuration**.

The use of the swivel bridge on M2 Series installations requires the use of a square bridge adapter and a 5' (1,5 m) square bridge (used for E, F, P and S Series setups), sold separately.

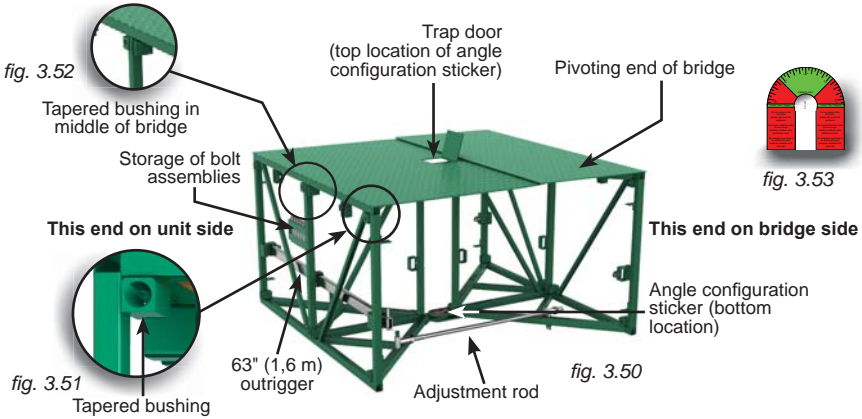

Installation of the square bridge adapter

- 1- Align the adapter (fig. 3.54) with the motorized unit. Assemble the top part of the adapter to the motorized unit using four 1" x 2" long (GR5) bolt and nut assemblies through the **four outer assembly sockets** (fig. 3.6, p. 44) in the front and back. **Do not tighten the bolt and nut assemblies yet.**
- 2- Attach the bottom part using bridge link plates and bolt assemblies. The farthest hole on the bridge link plates is not used for this setup (fig. 3.56).
- 3- Tighten all bolt assemblies to a torque of 100 lb-ft (136 N-m).

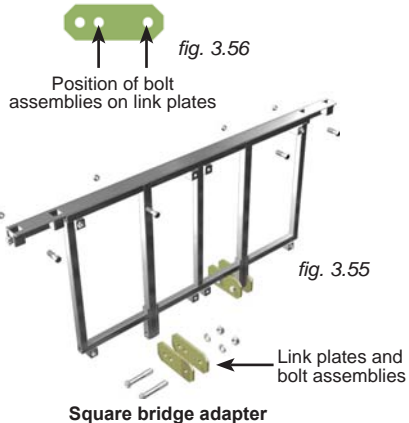
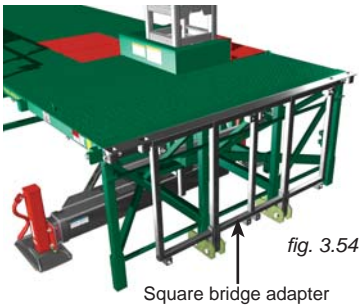

Bridge Setups

Swivel Bridge

Installation of the swivel bridge and the 5' (1,5 m) square bridge

- 1- Using the tapered bushings (fig. 3.51), align the swivel bridge with the adapter installed on the motorized unit. If the welded stoppers on the bottom trusses of the adapter and of the bridge prevent proper alignment, the swivel bridge is not properly positioned.
- 2- Attach the swivel bridge to the adapter using **six** bolt assemblies: one 5/8" x 5 1/2" (GR8) hex bolt, one 5/8" (GR8) lock washer and one 5/8" (GR8) nut in each of the four corner tapered bushings (fig. 3.50 and fig. 3.51, p. 56) and in either **one** of the tapered bushings (left or right) at the **top and bottom** in the middle of the bridge, fig. 3.50 and fig. 3.52, p. 56). Tighten all bolt assemblies to a torque of 120 lb-ft (163 N-m).
- 3- Repeat steps 1 and 2 to attach a 5' (1,5 cm) square bridge to the swivel bridge and to install any subsequent 5' (1,5 cm) square bridge, as required and allowed. Refer to p. 87 of the *Load Capacities* section for the number of bridges allowed in a swivel bridge installation.

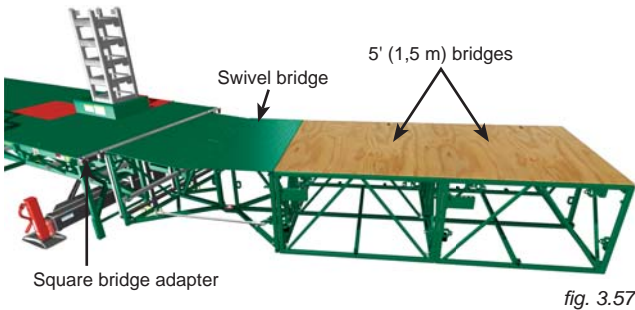
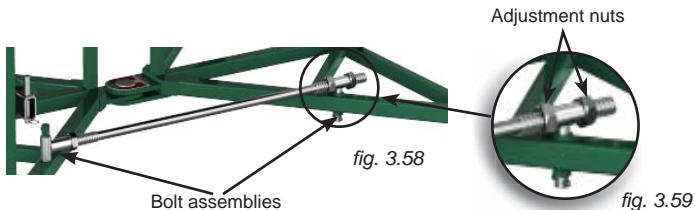

fig. 3.57

Angle adjustment

- 1- Make sure that the adjustment rod is installed on the appropriate side of the swivel bridge to achieve the desired configuration. If required, remove the bolt assemblies at both ends of the adjustment rod and reinstall on the other side of the swivel bridge (fig. 3.58).
- 2- Position the swivel bridge installation at the desired angle using the adjustment nuts (fig. 3.59). Refer to the angle sticker located under the trap door on the bridge deck or on the pivot pin at the bottom of the bridge (fig. 3.50, p. 56) to make sure the installation is at an appropriate angle. A swivel bridge configuration may only be installed at an angle between 0 and 45 degrees or at exactly 90 degrees towards the front.



Bridge Setups Swivel Bridge

Installation of standard guardrails

- 1- Install the 11" (28 cm) guardrail on the square bridge adapter (fig. 3.60).
- 2- Install the 60" (1,5 m) guardrail of the 5' 1,5 m square bridge (fig. 3.60).

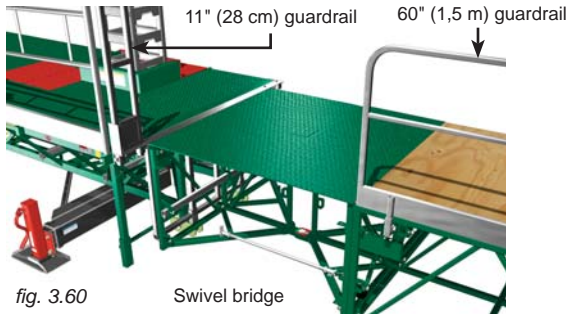

Installation of swivel guardrails

Swivel bridge installations require the use of special guardrails, included with each swivel bridge. The installation of guardrails on a swivel bridge will depend on the angle of the configuration.

Since not all swivel bridge guardrails may be necessary for a given configuration, refer to specific instructions for the configuration for the assembly of the appropriate guardrails.

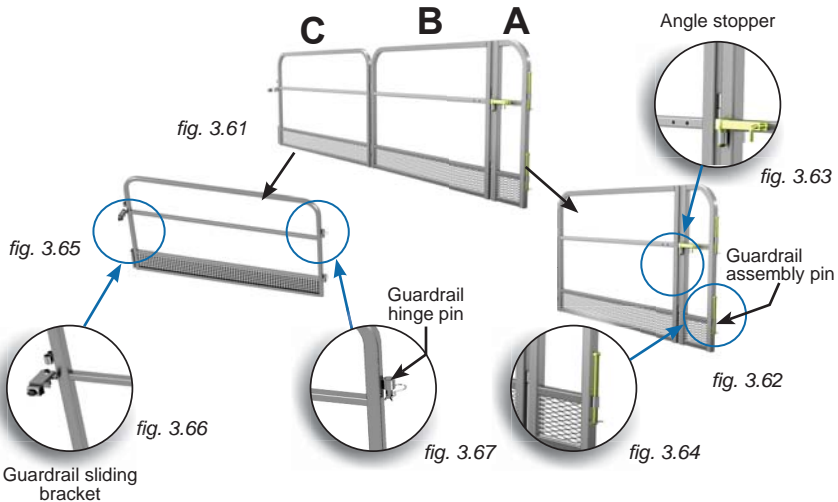

WARNING

Swivel bridge guardrails must not be used as a tie-off point.

Bridge Setups Swivel Bridge

Cantilever Configurations

Front cantilever configurations (0 to 45° and 90°)

- 1- Make sure that the adjustment rod is installed on the appropriate side of the swivel bridge to achieve the desired configuration. If required, remove the bolt assemblies at both ends of the adjustment rod and reinstall it on the other side of the swivel bridge (fig. 3.58, p. 57).
- 2- Lock the angle pivot between parts "A" and "B" of the swivel bridge guardrail assembly at 0° using the angle stopper (fig. 3.63, p. 58).
- 3- Align the hinge tubes on the swivel bridge guardrail assembly with the hinge tubes on the 11" (28 cm) guardrail on the square bridge adapter and secure in place with guardrail assembly pins (fig. 3.64, p. 58).
- 4- Insert the guardrail hinge pins on part "C" in the corresponding hinge tubes on part "B". Secure the assembly with hairpin cotter pins.
- 5- Install the 60" (1,5 m) guardrail of the square bridge attached to the swivel bridge.
- 6- Secure part "C" of the swivel bridge guardrail assembly to the 60" (1,5 m) guardrail by tightening the bolt on the sliding bracket (fig. 3.66, p. 58).
- 7- Make sure all the necessary guardrails are in place and secure (see the *Accessories* section on p. 91 for more information about guardrails). In all cases where workers are exposed to fall hazards greater than specified by local regulations, the installation of guardrails or face guardrail supports is **mandatory**.

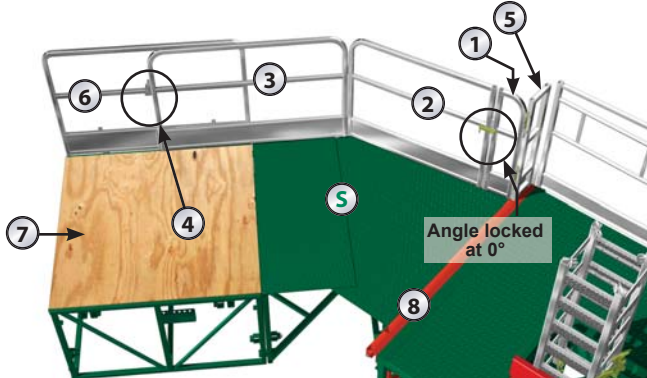

Front 0 to 45° cantilever configurations

fig. 3.68

LEGEND			
①	Part "A" of swivel bridge guardrail assembly	⑦	Square 5' (1,5 m) bridge
②	Part "B" of swivel bridge guardrail assembly	⑧	Adapter for square bridge
③	Part "C" of swivel bridge guardrail assembly	⑤	Swivel bridge
④	Sliding bracket to secure guardrails together	⑥	60" (1,5 m) guardrail for square bridge

Bridge Setups

Swivel Bridge

Swivel Bridge Counterweight Adapter (optional)

The optional counterweight adapter is required to install a square 5' (1,5 m) bridge to support a counterweight (not provided) in a swivel bridge installation with forward cantilever bridges. The use of a counterweight for any other swivel bridge configuration is not advantageous and should not be considered.

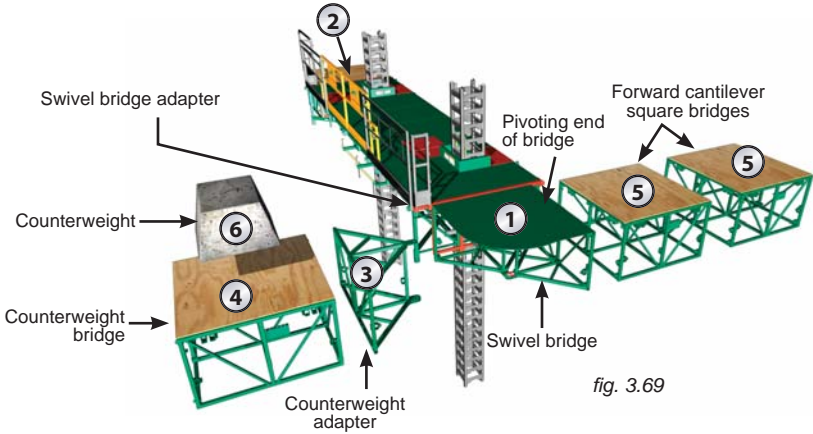

Recommended order of installation:

- 1 Square bridge adapter and swivel bridge
- 2 Cantilever bridge on opposite side of motorized unit (refer to *Load Capacities* section)
- 3 Counterweight adapter
- 4 Square 5' (1,5 m) counterweight bridge
- 5 Square 5' (1,5 m) forward cantilever bridges (as required and allowed)
- 6 Apply counterweight

Installation

- 1- Make sure that there are no bridges installed except for the swivel bridge and a 5' (1,5 m) modular bridge installed on the opposite cantilever side of the unit. For instructions on the installation of a swivel bridge, refer to p. 56 of this section. Refer to p. 57 of this section for instructions on the installation of a 5' (1,5 m) square bridge.
- 2- Make sure that the end of the swivel bridge that is not bolted to the adapter (pivoting end, fig. 3.69) is supported so the two halves of the swivel bridge remain together.
- 3- Remove the lock bolt from the top pivot pin (fig. 3.70, p. 61). It is not necessary to remove the lock bolt from the bottom pivot pin.
- 4- Lift out the top pivot pin until it clears the top part of the pivot structure (fig. 3.71, p. 61) and it is possible to align the hole in the top plate of the counterweight adapter. It is not necessary to remove the pivot pin completely. Lift out the bottom pivot pin until it is possible to insert the bottom plate (forked) of the counterweight adapter around the pivot pin.

Bridge Setups Swivel Bridge

Swivel Bridge Counterweight Adapter (optional)

Installation (cont'd)

- 5- Slide in the bottom plate of the counterweight adapter around the bottom pivot pin and align the hole of the top plate with the top pivot pin. Replace the top pivot pin.
- 6- Replace the lock bolt of the top pivot pin and tighten to secure.

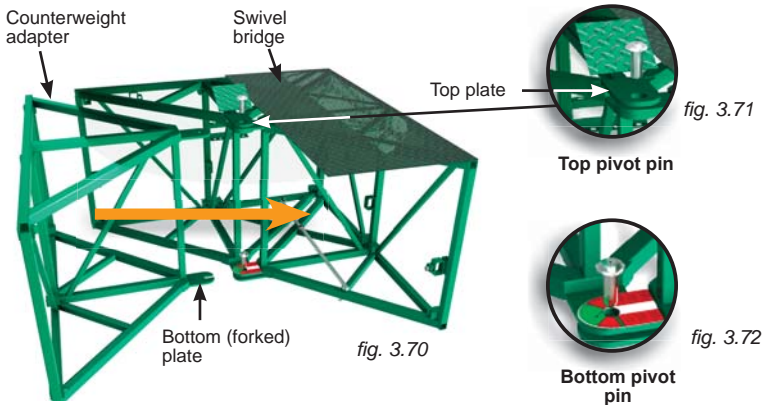

- 7- Secure the counterweight adapter to the frame of the swivel bridge with bolt assemblies to lock it into position (fig. 3.74).
- 8- Bolt a 5' (1,5 m) square bridge to the counterweight adapter as described in steps 1 through 3 of the installation instructions for a swivel bridge and a 5' (1,5 m) square bridge on p. 57 of this section.

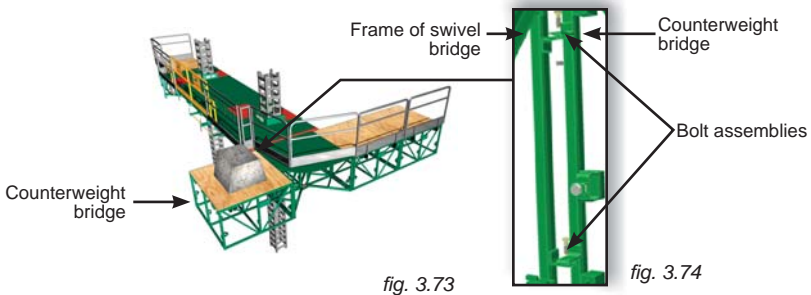

- 9- Install forward cantilever square bridges, as required and allowed (fig. 3.69, p. 60). Refer to the *Load Capacities* section on p. 80 for the number of bridges allowed in a configuration.
- 10- Apply the counterweight on the square bridge attached to the counterweight adapter. For information on the type of counterweight to apply, refer to p. 88 of the *Load Capacities* section.

Power Pack and Operating Components

Motorized unit preparation instructions

- 1- Remove the transport hook from one of the cylinders by taking off the linch pin and sliding out the GR8 clevis pin.

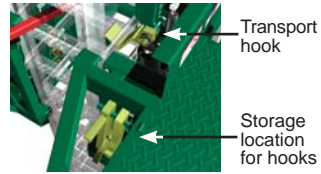

fig. 4.1



fig. 4.2

- 2- Retrieve a cylinder hook from the storage location.

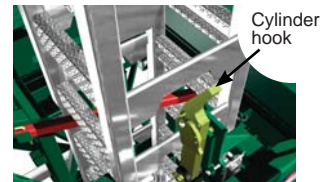

fig. 4.3

- 3- Make sure the rubber is in place and in good condition. Refer to p. 120 for more information about the replacement of the rubber in a cylinder hook. Place a cylinder hook on top of the cylinder. Secure the hook in place with the clevis pin and the linch pin clip.

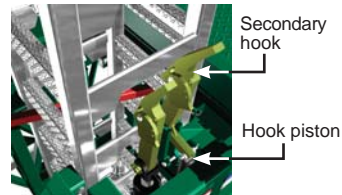

fig. 4.4

- 4- Retrieve the secondary hook and slide it on the secondary hook support. Secure the hook in place with the GR8 clevis pin and the linch pin, making sure the back horizontal part of the hook is secured to the top of the hook piston.

- 5- Store the transport hook in its storage location (fig. 4.1).

- 6- Repeat steps 1 through 5 for the cylinder and secondary hooks on the other mast.

- 7- Remove the mast locking bars from both masts (fig. 4.5) and store them in their storage location (fig. 4.6).



fig. 4.5



fig. 4.6



WARNING

Make sure both mast locking bars are removed before raising the platform. Mast locking bars must not be replaced with any other device or component.

Power Pack and Operating Components

Engine startup preparation instructions

- 1- Open the engine access panel (fig. 4.7).

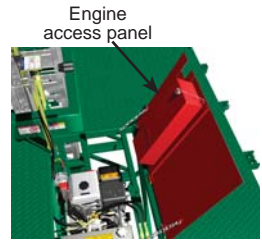

fig. 4.7

- 2- Pull the control post out of its storage location.

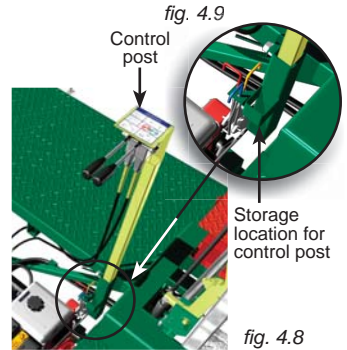

fig. 4.8

- 3- Slide the control post in the holding pocket until the stopper rests on top of the pocket.

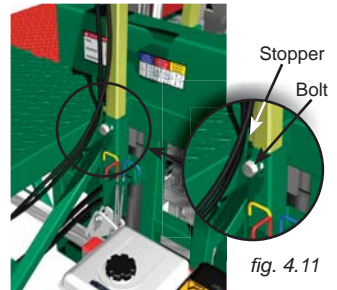

fig. 4.11

- 4- Secure the control post in place by tightening the pocket bolt.

fig. 4.10

- 5- Check the hydraulic oil level to make sure it is at least 3/4 full. Replenish if necessary.



fig. 4.12

- 6- Check the gasoline level and refill if necessary.



Power Pack and Operating Components

Engine startup preparation instructions

- 7- Check the engine oil level and refill if necessary.



- 8- If the motorized unit is brand-new or was not used for a significant amount of time, connect the battery.

Engine startup procedure

- 1- Move the engine gasoline shutoff valve lever to the ON position (fig. 4.15).
- 2- If the engine is cold, pull out the choke handle to the closed position (blue control handle, fig. 4.16). If the engine is warm, leave the choke handle in the open position.



fig. 4.14

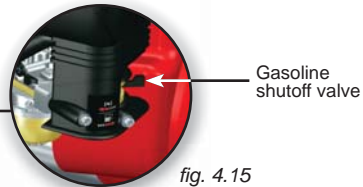

fig. 4.15

- 3- Pull out the throttle handle about halfway (yellow control handle, fig. 4.16).
- 4- Pull out the ignition handle (red control handle, fig. 4.16) and release it as soon as the engine is running (hold for a maximum of 10 seconds). If the engine does not start, wait another 10 seconds before trying again.
- 5- Once the engine has started, slowly push down the choke handle all the way to the open position.
- 6- Adjust the engine speed by pulling the throttle handle up to reach maximum RPM.
- 7- Before shutting down the engine, let it run at idle for about 30 seconds.
- 8- Use the ignition handle to shut down the engine. The choke handle must never be used to shut down the engine, as this will leave the ignition on and drain the battery.

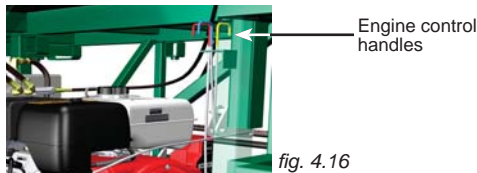

fig. 4.16

Storage of the control post

To store the control post, loosen the bolt on the control post pocket located on the motorized unit and pull out the control post completely. Insert the control post in its storage pocket and let it slide down slowly until the cover plate sits on the storage pocket.





WARNING

The choke handle (blue control handle) must never be used to shut down the engine, as this will leave the ignition on and drain the battery. Before shutting down the engine, let it run at idle for about 30 seconds.

Power Pack and Operating Components

SAFETY comes first. The raising and lowering of the platform must be visually monitored at all times. It is mandatory to make sure that **both** hooks are properly engaged on a mast rung on each mast before raising or lowering the platform. Failure to engage the hooks correctly may cause the platform to drop, leading to equipment damage, injury, even death.

	<p>RAISING the control levers will cause the cylinders to extend and generate a downward motion of the platform</p> <p>GREEN ARROW indicates to raise and hold the control levers until the cylinders extend completely</p> <p>YELLOW ARROW indicates to raise and hold the control levers until the cylinders have extended sufficiently for the task to perform</p>
	<p>LOWERING the control levers will cause the cylinders to retract and generate an upward motion of the platform</p> <p>GREEN ARROW indicates to lower and hold the control levers until the cylinders retract completely</p> <p>YELLOW ARROW indicates to lower and hold the control levers until the cylinders have retracted sufficiently for the task to perform</p>

Raising the platform

- 1- Before raising the platform, make sure that the motorized unit and plank outriggers clear the building, balconies, etc., that the mast tie door is open and that planking has been removed from in front of each mast when passing a tie level.

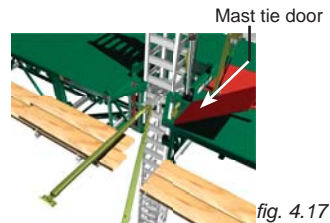

- 2- Lock the lowering cams on the cylinder hook and the secondary hook on each mast (fig. 4.18).

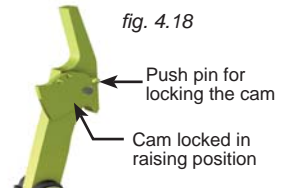

- 3- Make sure that the engine is running at full throttle. Visually make sure that the cylinder hook and the secondary hook are properly engaged (fig. 4.19 and fig. 4.20) and on the same mast rung (fig. 4.23, p. 66) on both masts. Failure to engage the hooks correctly can cause the platform to drop.

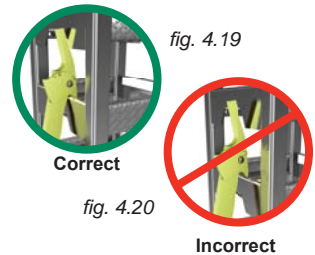

To facilitate rise and descent operations, it is suggested to engage both the cylinder hook and the secondary hook on the same mast rung on both masts, as shown in fig. 4.23, p. 66.



WARNING

Visually make sure the cylinder hook and the secondary hook are properly engaged on a mast rung on each mast before raising or lowering platform (fig. 4.19 and fig. 4.20). Failure to engage hooks correctly can cause the platform to drop, leading to equipment damage, injury, even death.

Power Pack and Operating Components

Raising the platform (cont'd)

- 4- Raise the control levers until the hydraulic cylinders are extended completely (to a height equal to two rungs) (fig. 4.21). The engine will slow down when the cylinders are fully extended.

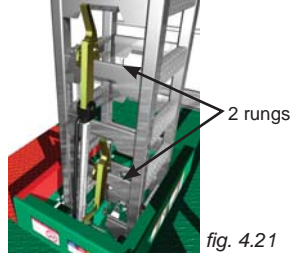

- 5- Lower the control levers so the cylinder hooks lower enough to engage onto a mast rung.



Check visually on both masts to make sure that the cylinder hooks are properly engaged on a mast rung.

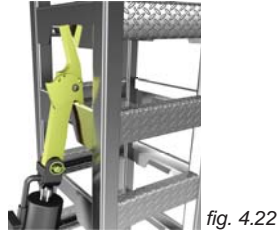

- 6- Lower the control levers and let the platform rise until each secondary hook is above the rung where the cylinder hook is engaged. The lift can be 10" or 20" (25,4 cm or 50,8 cm), or a height equal to one or two mast rungs.



- 7- Raise the control levers enough to engage the secondary hook on the mast rung on each mast. Both hooks should now be side by side on the same mast rung on both masts.

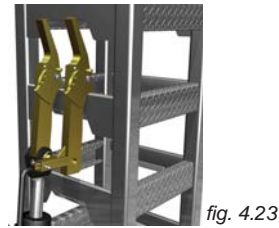

- 8- Repeat steps 4 through 7 to continue raising the platform.
- 9- Once the platform has reached the desired height, make sure that both hooks are properly engaged on the same mast rung on each mast.



WARNING

In a bearing bridge configuration, it is mandatory to coordinate the raising and lowering operations on each motorized unit linked by the bearing bridge to ensure that any slope of the bridge structure does not exceed 2 degrees or 1" / 24" (35 cm / 61 cm).



The use of shorter planks will facilitate the passing of tie levels.



WARNING

The use of fall protection equipment is **mandatory** to handle operations when passing tie levels. Properly tied to the unit, slide planks away from in front of the masts and open the mast tie doors. Close the mast tie doors once the tie levels are passed.

Power Pack and Operating Components

Lowering the platform

- 1- Before lowering the platform, make sure that the motorized unit and plank outriggers clear the building, balconies, etc., that the mast tie door is open and that planking has been removed from in front of each mast when passing a tie level.

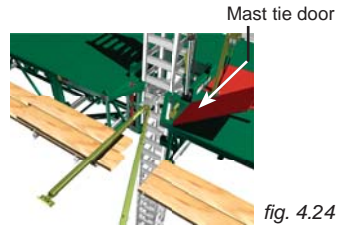

- 2- Unlock the lowering cam on both the cylinder hook and the secondary hook on both masts (fig. 4.25).

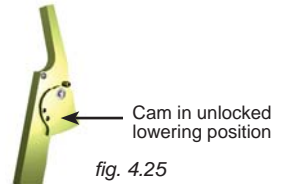

- 3- Make sure that the engine is running at full throttle. Visually make sure that the cylinder hook and the secondary hook are properly engaged (fig. 4.26 and fig. 4.27) and on the same mast rung (fig. 4.32, p. 68) on both masts. Failure to engage the hooks correctly can cause the platform to drop.

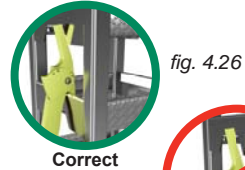

- 4- Lower the control levers to retract the cylinders completely so the lowering cam on each secondary hook can swing toward the mast. The engine will slow down when the cylinders are fully retracted.

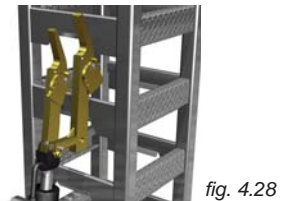

- 5- Raise the control levers to extend the cylinders completely. The engine will slow down when the cylinders are fully extended. The platform will lower by 10" or 20" (25,4 cm or 50,8 cm), or a height equal to one or two mast rungs (fig. 4.29).

**WARNING**

Visually make sure the cylinder hook and the secondary hook are properly engaged on a mast rung on each mast before raising or lowering platform (fig. 4.26 and fig. 4.27). Failure to engage hooks correctly can cause the platform to drop, leading to equipment damage, injury, even death.

Power Pack and Operating Components

Lowering the platform (cont'd)

- 6- Lower the control levers to retract the cylinders enough so the secondary hook is above the mast rung on each mast (but not its lowering cam).



- 7- Raise the control levers so the secondary hooks lower enough to engage onto the mast rungs.



Before lowering the platform, check visually to make sure that the secondary hook is properly engaged on the mast rung on both masts.



fig. 4.30

- 8- Raise the control levers again to extend each cylinder completely and force its lowering cam to swing toward the mast.



- 9- Lower the control levers to fully retract the cylinders completely. The engine will slow down when the cylinders are fully retracted.



- 10- Raise the control levers to extend each cylinder enough until its hook is above the mast rung (but not its lowering cam).



- 11- Lower the control levers so the cylinder hooks lower enough to engage onto the mast rungs.



Both the cylinder and secondary hooks will be side by side on the same mast rung on each mast.



fig. 4.31

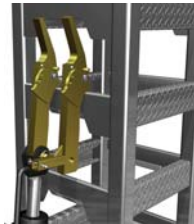

fig. 4.32

- 12- Repeat steps 4 through 11 to continue lowering the platform.
- 13- Monitor the last 10' (3 m) of lowering to base level to ensure the proper seating of the access walkway.
- 14- Once the platform has been brought down to base level or to the desired height, make sure that both hooks are properly engaged on the same mast rung on each mast.



WARNING

In a bearing bridge configuration, it is mandatory to coordinate the raising and lowering operations on each motorized unit linked by the bearing bridge to ensure that any slope of the bridge structure does not exceed 2 degrees or 1" / 24" (35 cm / 61 cm).



WARNING

The use of fall protection equipment is **mandatory** to handle operations when passing tie levels. Properly tied to the unit, slide planks away from in front of the masts and open the mast tie doors. Close the mast tie doors once the tie levels are passed.

Masts and Mast Ties

The installation of mast sections must be performed with care. The front face of mast sections must always be parallel to the face of the work. It is important to verify that each mast remains parallel throughout the installation of mast sections.

Mast sections loaded on the motorized unit using a crane or a rough terrain forklift **must be stored horizontally on the motorized unit to ensure good balance**. Refer to the *Load Capacities* section on p. 80 for more information about loading the motorized unit.

Installation of a mast section

- 1- To connect one mast section to another, align the mast section to be installed on top of the bottom mast section. Insert the anti-error stubs on top of the bottom section into the bottom tubes of the section to be installed, making sure the mast sections line up square and that rungs for the hooks are on the same side.
- 2- Flip the 5/8" x 6 1/2" toggle bolt, mast clamp and flange nut onto the connecting lug and tighten by hand. Perform this operation for all four (4) corners.
- 3- Tighten all toggle bolts to 120 lb-ft (163 N-m) of torque. Use a cross-pattern sequence when tightening (fig. 5.1).
- 4- Repeat steps 1, 2 and 3 for each mast section to be installed at every 5' (1,5 m) of rise. Install mast sections alternately – on one mast, then on the other.
- 5- For faster assembly, lengths of mast sections can be pre-assembled (also referred to as "sticks"). The length of pre-assembled mast allowed is equal to the height in feet (meters) authorized between tie levels for the installation. For more information about tie levels, refer to the *Mast Tie Installation Schedule* on p. 70 of this section. It is recommended to use an optional multiple mast handler to handle pre-assembled lengths of mast sections. For instructions on the use of the optional mast handler, refer to p. 117 of the *Accessories* section.
- 6- Always make sure that the mast assemblies are plumb on both the front and side axis.
- 7- It is important to make sure to verify the mast bolts on each mast when lowering the platform to make sure they are in good condition and tightened to the proper torque, especially on **brand-new mast sections**, as the galvanized coating may have compressed. In all cases, mast bolts must be tightened to a torque of 120 lb-ft (163 N-m). Failure to tighten bolts properly may lead to serious injury or death.

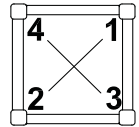



fig. 5.1

 WARNING / AVERTISSEMENT / ADVERTENCIA		
<p>It is important to make sure to verify the mast bolts on each mast before using the installation and when lowering the platform to make sure they are tightened to the proper torque and are in good condition, especially on brand-new mast sections, as the galvanized coating may have compressed.</p> <p>In all cases, mast bolts must be tightened to a torque of 120 lb-ft (163 N-m). Tightening mast bolts to a lower or higher torque than the torque prescribed may lead to serious injury or death.</p>	<p>Il est important de vérifier les boulons de mât sur chaque mât avant d'utiliser l'installation ou lors de la descente de la plate-forme afin de s'assurer qu'ils sont en bon état et qu'ils sont resserrés au bon couple de serrage, particulièrement pour les sections de mât toutes neuves, puisque le revêtement galvanisé peut s'être comprimé.</p> <p>Dans tous les cas, il faut resserrer les boulons de mât à un couple de serrage de 120 lb-pi (163 N-m). Resserrer les boulons de mât à un couple de serrage supérieur ou inférieur au couple de serrage prescrit peut entraîner des blessures sérieuses, voire la mort.</p>	<p>Es importante verificar los pernos de mástil on cada mástil antes de usar la instalación o durante la bajada de la plataforma para asegurar que estén en buenas condiciones y que estén apretados al par de torsión apropiado, siempre que la capa galvanizada puede haberse comprimido.</p> <p>En todos los casos apriete los pernos del mástil a un par de torsión de 120 lb-ft (163 N-m). Apretar los pernos de mástil a un par de torsión inferior o superior al par prescrito puede causar lesiones graves o la muerte.</p>
		<small>A0801900-0001 R0.03</small>

fig. 5.2

 WARNING	
<p>It is important to make sure to verify the mast bolts when lowering the platform to make sure they are in condition and are tightened to the proper torque, especially on brand-new mast sections, as the galvanized coating may have compressed.</p>	

Masts and Mast Ties

Installation of mast ties

- 1- Slide the mast tie attachment assembly into the mast section.
- 2- Spread open the mast tie attachment assembly until the four corner stoppers are positioned properly.
- 3- Flip the 5/8" x 6 1/2" toggle bolt, mast clamp and flange nut on the mast tie attachment assembly and tighten to 120 lb-ft (163 N-m) of torque.
- 4- Refer to p. 72 and p. 73 for the plank configuration appropriate for the setup. Refer to the *Mast Tie Components Requirements - 0-4 planks* table on p. 72 and the *Mast Tie Components Requirements - 5-8 planks* table on p. 73 to choose the components required according to the plank configuration.

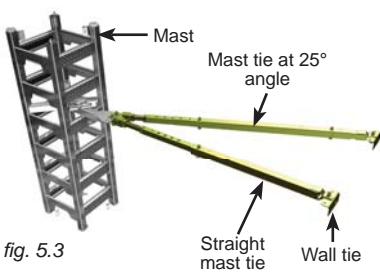

fig. 5.3

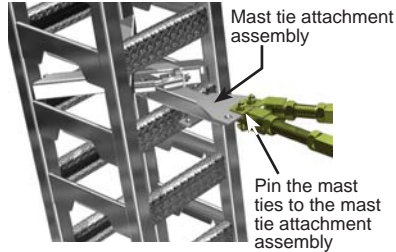

fig. 5.4

fig. 5.5

MAST TIE INSTALLATION SCHEDULE			
Platform height	Standard setup (0 to 4 planks)	Non standard configurations	Sidewalk canopy adapter base or mast base plate
14' (4,3 m) units 0 - 25' (0 - 7,6 m)	Freestanding (not more than 3 planks allowed)	No freestanding allowed	No freestanding allowed
24' (7,3 m) units 0 - 35' (0 - 10 m)	Freestanding (not more than 3 planks allowed)	No freestanding allowed	No freestanding allowed
0 - 250' (0 - 76 m) (both unit models)	Every tie at 20' (6 m) OR 30' (9,1 m) with tie levels pre-installed to the top of the setup before the start of any work	Every tie at 10' (3 m) OR 20' (6 m) with tie levels pre-installed to the top of the setup before the start of any work	First tie level at 5' (1,5 m) from base of mast (three mast ties per mast for first tie level)
			Second tie level at 5' (1,5 m) above first tie level (three mast ties per mast for second tie level)
			All subsequent tie levels as per setup (see corresponding column at left)
Maximum travel distance above the last tie level	20' (6,1 m)	10' (3 m)	See corresponding column at left

Definition of a non standard configuration

A **non standard configuration**, referred to throughout this owner's manual and related documentation, is an installation that **requires** the use of additional equipment, such as a forward extension bridge, a swivel bridge or a planking configuration wider than four planks or the use of accessories such as weather protection, a hoist or a monorail.



WARNING

It is important to verify each mast tie of an installation that has been exposed to winds exceeding 94 mph (150 km/h).

Masts and Mast Ties

Installation of mast ties (cont'd)

- 5- Pin the required straight mast tie to the mast tie attachment using a clevis pin and a linch pin.
- 6- Pin the straight mast tie to the wall tie and adjust its length until the mast is perfectly plumb on the front axis. Use the threaded rod and the pin for adjustment, leaving a maximum length of threaded rod inside the mast tie tube for added strength.
- 7- Install the required mast tie at a 25° angle (fig. 5.1, p. 69) and use the threaded rod to adjust its length until the mast is perfectly plumb on the side axis. Mast ties installed at a 25° angle must be installed outside or inside, using the same configuration on both masts, as shown in fig. 5.6 and fig. 5.7. Mast ties must never be installed in a parallel fashion.



WARNING - WIND SPEEDS

The **erection and dismantling** of a motorized unit setup (including the base, the bridges, the masts, the mast ties and all the other components) must not be conducted when wind speeds exceed **28 mph (45 km/h)**. **Freestanding installations and setups equipped with weather protection**, when allowed, must not be used with wind speeds exceeding **28 mph (45 km/h)**. **Weather protection**, when allowed, **must not be used** when work is performed on an **open air structure**. A motorized unit setup with **mast ties must not be operated** when wind speeds exceed **35 mph (56 km/h)**.

When a motorized unit is not in use

- It is mandatory to leave the platform between two tie levels when the motorized unit is not in use.
- Remove all loads from the setup when the motorized unit is not in use.
- It is mandatory to leave all the counterweights applied on the setup in place when the motorized unit is not in use.
- In a freestanding installation, when allowed, the motorized unit must be brought down to base level when not in use.
- If wind speeds are expected to exceed **94 mph (150 km/h)**, the motorized unit must be brought down to base level when not in use.

APPROPRIATE MAST TIE INSTALLATION

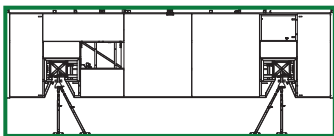
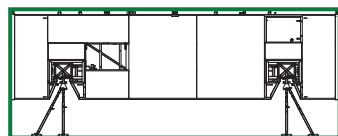

fig. 5.6

INSIDE

OR



OUTSIDE

fig. 5.7

INCORRECT MAST TIE INSTALLATION

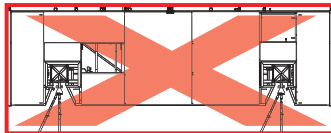

fig. 5.8

Mast ties must always be installed with the angled mast tie outside or inside, as shown in fig. 5.6 and fig. 5.7, using the same configuration for both masts. Mast ties must never be installed in a parallel fashion as shown in fig. 5.8.

Masts and Mast Ties

Mast Tie Requirements for Planking Configurations
0 to 4 Planks Configurations

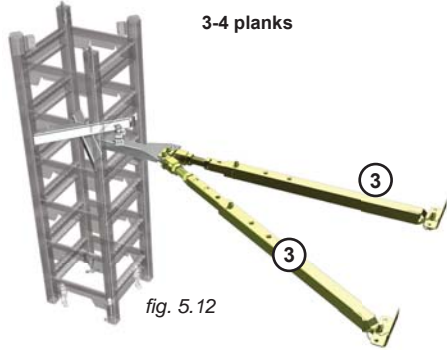
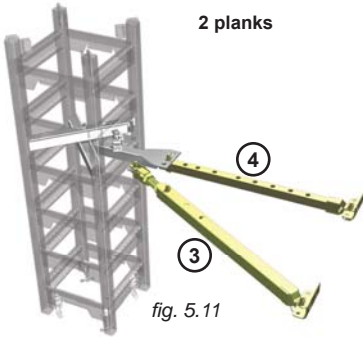
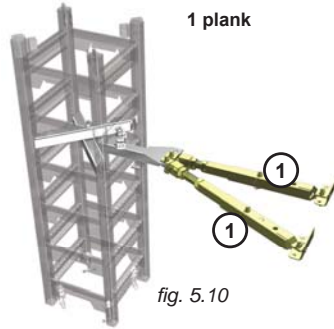
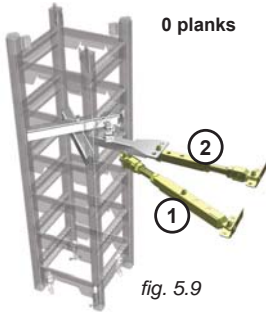
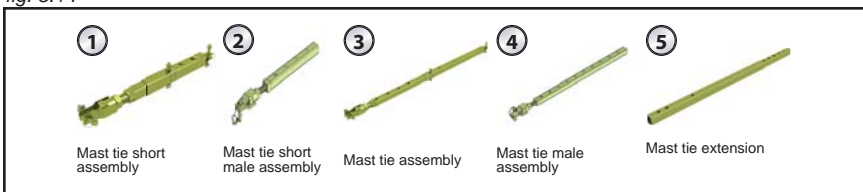

fig. 5.13

MAST TIE REQUIREMENTS FOR PLANK CONFIGURATION - 0 to 4 PLANKS						
Ref	Component	0 planks	1 plank	2 planks	3 planks	4 planks
①	Mast tie short assembly	1	2	0	0	0
②	Mast tie short male assembly	1	0	0	0	0
③	Mast tie assembly	0	0	1	2	2
④	Mast tie male assembly	0	0	1	0	0

Note: Parts required are based on number of planks x 10" (25,4 cm) + 6" to 8" (15 cm to 20 cm) of play per mast per tie level

fig. 5.14



Masts and Mast Ties

Mast Tie Requirements for Planking Configurations 5 to 8 Planks Configurations

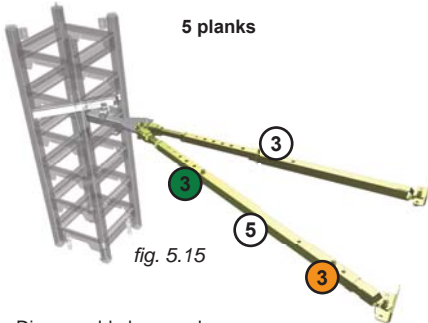

Assembling a mast tie and a mast tie extension

- 1- Remove the mast tie pin holding both ends of the mast tie assembly together.
- 2- Insert the male end of the mast tie assembly into the female end of the mast tie extension and secure with a mast tie pin.
- 3- Insert the male end of the mast tie extension into the female end of the mast tie assembly and secure with a mast tie pin.

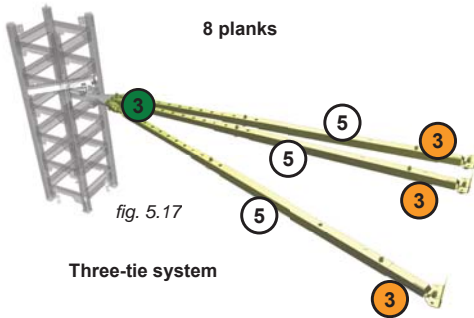
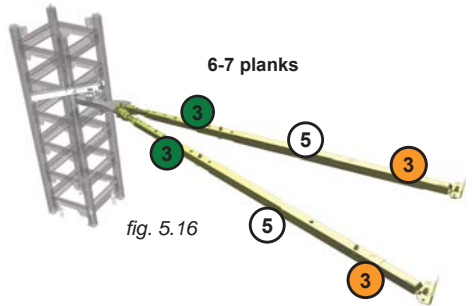
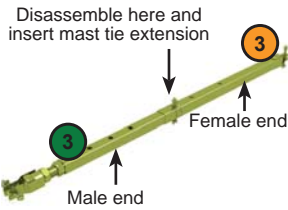

Three-tie system

MAST TIE REQUIREMENTS FOR PLANK CONFIGURATION - 5 to 8 PLANKS					
Ref	Component	5 planks	6 plank	7 planks	8 planks
③	Mast tie assembly	2	2	2	3
⑤	Mast tie extension	1	2	2	3
Note: Parts required are based on number of planks x 10" (25,4 cm) + 6" to 8" (15 cm to 20 cm) of play per mast per tie level					

fig. 5.19

fig. 5.18

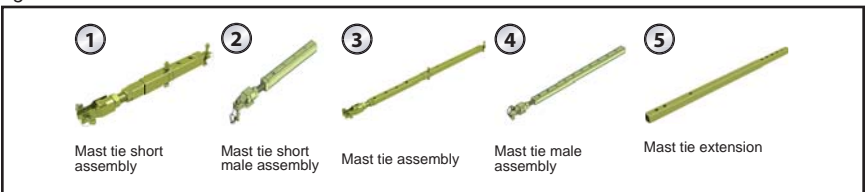

Masts and Mast Ties

Angle of Mast Ties and Wall Tie Distances 0 to 7 Planks Configurations

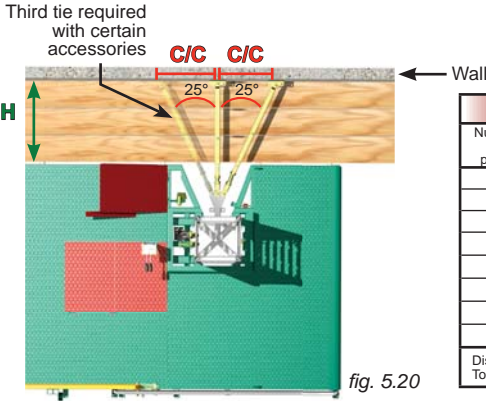

Wall tie distance		
Number of planks	H in (cm)	C/C in (cm)
0	8" (20 cm) minimum	11" (28 cm)
1	17" (43 cm)	15" (38 cm)
2	27" (69 cm)	21" (53 cm)
3	37" (94 cm)	24" (61 cm)
4	47" (119 cm)	33" (84 cm)
5	57" (145 cm)	34" (86 cm)
6	68" (173 cm)	38" (97 cm)
7	78" (198 cm)	42" (107 cm)

Distances above are given as a reference only. Tolerance rate is of $\pm 2"$ (5 cm).

fig. 5.21



The planking configurations (5, 6, 7 and 8 planks) shown on the previous page require the use of optional outriggers and accessories. Refer to p. 95 of the *Accessories* section for more information on outriggers and planking configurations.

Angle of Mast Ties and Wall Tie Distances 8 Planks Configuration

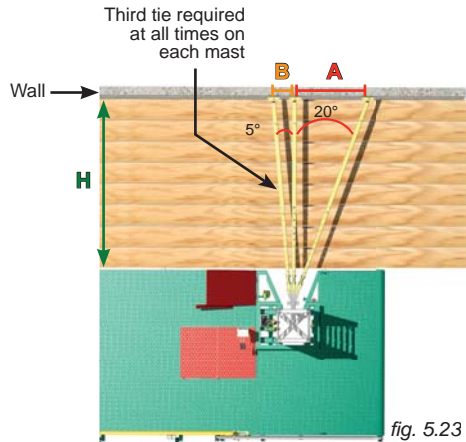
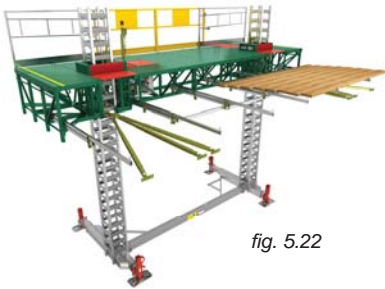

Wall tie distance			
Number of planks	H in (cm)	A in (cm)	B in (cm)
8	88" (223 cm)	37" (94 cm)	11" (28 cm)

Distances above are given as a reference only. Tolerance rate is of $\pm 2"$ (5 cm).

fig. 5.24

A planking configuration with 8 planks requires a **three-tie system on each mast**. It is important to refer to p. 95 of the *Accessories* section for more information about wide plank configurations and their restrictions.

Masts and Mast Ties

Passing mast tie levels

The use of fall protection equipment is **mandatory** to handle operations when passing tie levels. To safely pass mast tie levels, slide planks away from the front area of each mast and open the mast tie doors. The use of shorter planks will facilitate this task. It is recommended to use the designated tie point located on the motorized unit and on the substructure to anchor the fall protection equipment. For information about tie points on the units and the substructure, refer to p. 42 of the *Accessories* section.

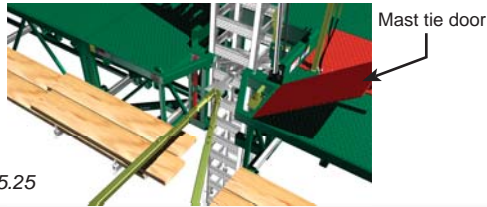

fig. 5.25



The use of shorter planks will facilitate the passing of tie levels.

Removal of mast ties

- 1- Loosen the adjustment rod on the angle mast tie until the mast tie is loose enough to be easily unfastened from the wall tie installed on the face of the work.
- 2- Repeat step 1 for the straight mast tie. The straight mast tie must be the last mast tie removed.
- 3- Repeat steps 1 and 2 for each tie level on each mast.

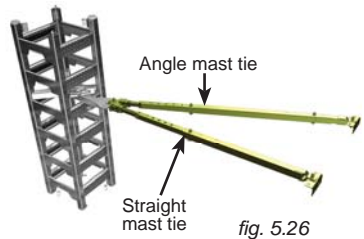

WARNING

It is **mandatory** to make sure that **all tension (or compression)** is released from the mast tie before attempting to unpin it from the wall tie.

Removal and transport of mast sections

- 1- To remove one mast section, loosen the toggle bolt assembly and disengage from the connecting lug (fig. 5.27). Perform this operation for all four (4) corners.
- 2- Pull the top mast section off the bottom mast section. If mast sections are to be stored on the platform during dismantling, make sure they are set down horizontally and distributed equally on the motorized unit.
- 3- Store mast sections on a flat surface away from work areas and construction traffic.
- 4- Masts can be removed and carried in lengths of mast sections (also referred to as "sticks"). It is recommended to use an optional multiple mast handler to handle pre-assembled lengths of mast sections. For instructions on the use of the optional mast handler, refer to p. 117 of the *Accessories* section.
- 5- For best results when carrying mast sections in bundles, it is recommended to strap them in groups of nine (9). Make sure that mast sections positioned in the middle are securely strapped to the other sections to prevent them from slipping out during transport.



fig. 5.27

Masts and Mast Ties

Angled Mast Ties

Some mast tie configurations require that the mast ties be attached at an angle (between 5 and 30 degrees from horizontal) through windows or other building openings (fig. 5.32).

These angled mast tie configurations require the use of the optional 30-degree mast tie kit (fig. 5.28) and an anchoring system suitable for ties on a floor. An angled mast tie installation **must not exceed** a 30-degree angle from horizontal (fig. 5.33, p. 77). It is **mandatory** to use **three** mast ties for each tie point of an angled mast tie installation.

Only **one** optional mast tie extension is allowed for each mast tie in an angled mast tie configuration.

fig. 5.28

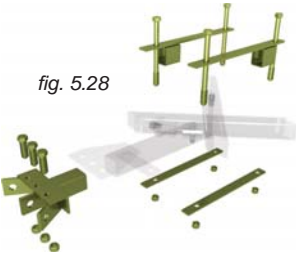

Mast tie attachment assembly with 30-degree mast tie kit



Mast tie bracket – type 2 fig. 5.29

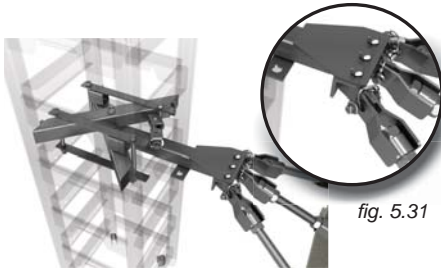

fig. 5.31

fig. 5.30 Angle bracket

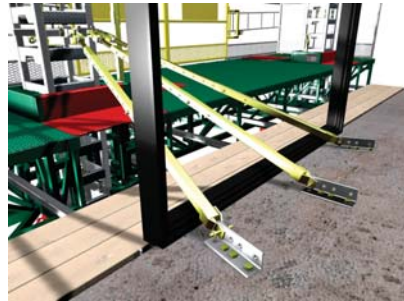

fig. 5.32

Installation of the angle bracket

- 1- Install the mast tie attachment assembly as described in steps 1 through 3 of the mast tie installation procedure on p. 70.
- 2- Slide the top part (two angle bars) of the 30-degree mast tie bracket in the mast over the mast tie attachment assembly and make sure they are inserted in both the front and back mast rungs (fig. 5.30).
- 3- Slide the bottom part of the 30-degree mast tie bracket in the mast under the mast tie attachment assembly.
- 4- Align the top two angle bars with the bottom part of the 30-degree mast tie bracket and bolt them together using 5/8" bolt and nut assemblies (4).
- 5- Attach the angle bracket (fig. 5.31) to the front of the mast tie attachment assembly with 9/16" bolt, washer and nut assemblies (3).
- 6- Tighten all the nut and bolt assemblies to 60 lb-ft (81 N-m) of torque.



WARNING

An angled mast tie installation **must not exceed** a 30-degree angle from horizontal. Only **one** optional mast tie extension is allowed for **each** mast tie in an angled mast tie configuration.

Masts and Mast Ties

Angled Mast Ties

Installation of extended mast ties

- 1- Remove the linch pin and clevis pin joining the two parts of the mast tie assembly together.
- 2- Insert the male part of the mast tie assembly into an optional mast tie extension. Secure with a clevis pin and a linch pin.
- 3- Insert this new assembly into the female part of the mast tie assembly. Secure with a clevis pin and a linch pin.
- 4- Pin the required straight mast tie to the mast tie attachment using a clevis pin and a linch pin.
- 5- Pin the straight mast tie to the floor tie and adjust its length until the mast is perfectly plumb on the front axis. Use the threaded rod and the pin for adjustment, leaving a maximum length of threaded rod inside the mast tie tube for added strength. Floor ties must be able to sustain 1500 lb (680 kg) of tension/compression and 3000 lb (1361 kg) of shear force.
- 6- Repeat steps 1 through 5 to install the other **two** required mast ties at a 25° angle (fig. 5.20, p. 74) and use the threaded rods to adjust their length until the mast is perfectly plumb on the side axis.

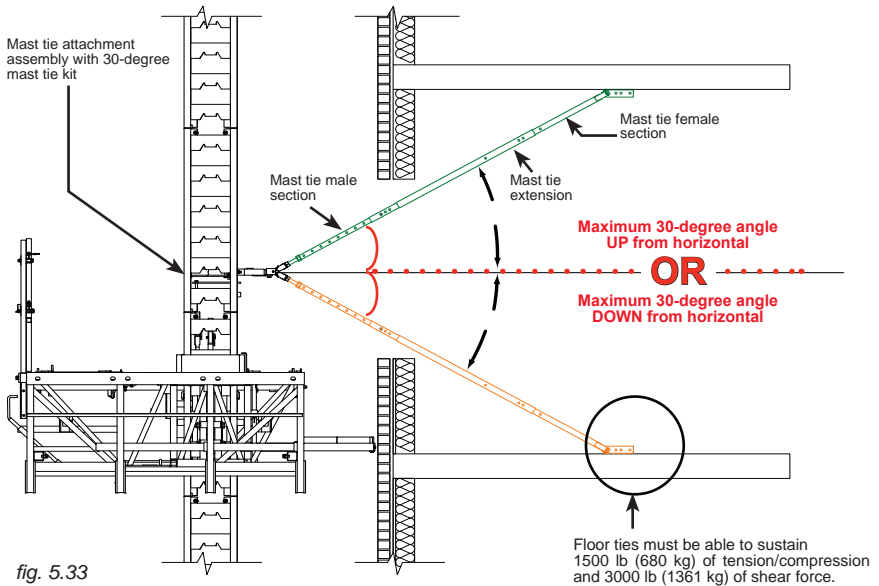

0 to 30-degree UPPER angle
OR
 0 to 30-degree LOWER angle

Calculation of a mast tie angle

A 5-degree slope represents a 12" to 1" (30 cm to 2,5 cm) ratio

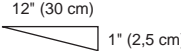

A 30-degree slope represents a 12" to 7" (30 cm to 18 cm) ratio

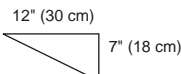

Masts and Mast Ties

Anchoring System

Wall tie types

Before attaching masts to the building using the mast tie system, wall ties must be installed on a solid component of the building structure. It is important to understand that whether the anchoring installation is a wall or floor type, values for tension / compression and shear forces will be **inverted**.

Concrete slabs, columns, steel beams, relief angles and other structural elements can be used provided they and the anchoring system chosen can sustain 3000 lb (1360 kg) of tension / compression and 1500 lb (680 kg) of shear force for an **anchoring installation on a wall** and 1500 lb (680 kg) of tension / compression and 3000 lb (1360 kg) of shear force for an **anchoring installation on a floor**.

There are 4 types of wall ties that can be used. As the installation is rising, install the wall ties as per the *Mast Tie Schedule* table (fig. 5.5, p. 70). **It is important to note that M1 Series wall ties do not meet minimum strength requirements for Hydro Mobile M2 equipment setups.**

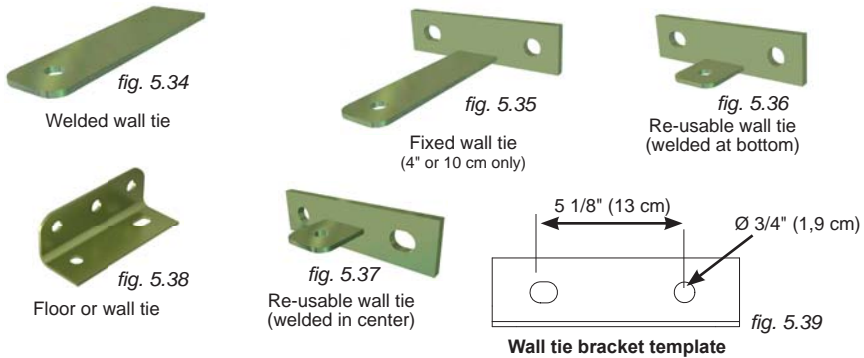



 WARNING / AVERTISSEMENT / AVISO		
<p>Wall ties must be installed on a structure capable of withstanding 3000 lb (1360 kg) of tension or compression and 1500 lb (680 kg) of shear.</p> <p>Adjust mast ties until mast is plumb.</p>	<p>Les attaches murales doivent être installées sur une structure pouvant résister à une traction ou compression de 1360 kg (3000 lb) et une force de cisaillement de 680 kg (1500 lb).</p> <p>Ajuster les attaches de mât de façon à ce que le mât soit d'aplomb.</p>	<p>Las ataduras murales deben ser puestos sobre una estructura capaz de resistir a una tracción o compresión de 1360 kg (3000 lb) y una fuerza de cizallamiento de 680 kg (1500 lb).</p> <p>Ajustar las ataduras de mástil para poner el mástil de plomo.</p>
A0800500-0005		

fig. 5.40

	<p>WARNING</p> <p>It is important to note that M1 Series wall ties do not meet minimum strength requirements for Hydro Mobile M2 equipment setups.</p>
--	--

Masts and Mast Ties

Anchoring System

Installation guidelines for floor ties

Floor anchoring can be installed at angles ranging from 0° up to 30° from horizontal. Floor ties must be able to sustain 1500 lb (680 kg) of tension/compression and 3000 lb (1361 kg) of shear force.



fig. 5.41

Floor tie

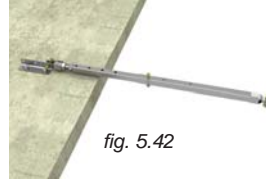

fig. 5.42

Installation guidelines for fixed wall ties

Fixed wall ties can be installed on a wall between two layers of brick (fig. 5.43). It is important to make sure that several layers of brick have been laid on top of the fixed wall ties and that the mortar has cured properly **before attaching mast ties to the wall ties**.

Distance between the anchoring structure and the back of the brick wall must not be greater than 1 1/2" (3,8 cm), as show in fig. 5.44.



fig. 5.43

Maximum distance
1 1/2" (3,8 cm)

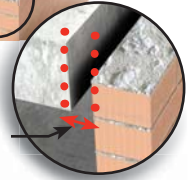

fig. 5.44

Installation guidelines for a welded wall tie on a beam

The welded wall tie is 6 7/8" (17,5 cm) long and should protrude from the beam by a maximum of 3 7/8" (10 cm), as shown in fig. 5.46.

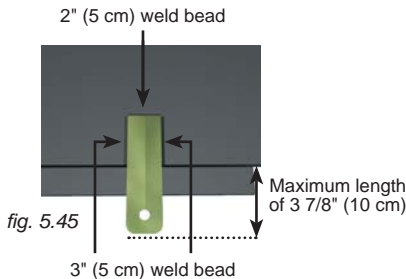

fig. 5.45

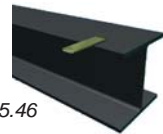

fig. 5.46

Wall tie welded to beam

The welded wall tie can be fastened to the beam by three 3/16" (5 mm) wide weld beads. The two weld beads along the length of the wall tie will be 3" (5 cm) long, while the weld bead along the width of the wall tie will be 2" (5 cm) long.

Installation guidelines for a re-usable wall tie

Used mainly for masonry work projects, the re-usable wall tie is installed in a cavity left unfilled in a brick wall under construction.

When dismantling the setup and removing mast ties, the re-usable wall tie is removed and the brickwork is completed.



fig. 5.47

Installation of the re-usable
wall tie

Load Capacities

Changes to the calculation method of load capacities

It is important to note that in versions prior to version 4.0 of the M2 Series owner's manual, the load allowed to be placed on a bridge or a unit was as shown in the load capacities charts: users did not have to take into account the weight of planks or the weight of workers (including their personal tools) on the setup, except for the number of workers. The interpretation of the M2 Series load capacities diagrams has been modified in order to standardize the method used for all Hydro Mobile series.

For point load configurations, contact the Hydro Mobile technical support team.

Load capacity calculation guidelines

The load capacities charts included in this owner's manual apply to installations using modular bridges or old-style bridges, as well as a combination of both.

- 1- **The weight of planks and any additional accessory being used must be deducted from the load capacities.**
- 2- **Each worker's weight (personal tools and equipment included) must be deducted from load capacities.**
- 3- To ensure stability in a single unit modular setup, the length of cantilever bridges on either side of the unit must be equal at all times, with the exception of the setup shown in the single unit capacity chart for 24' (7,3 m) units. It is also recommended that the loads applied on the platform be as evenly distributed as possible.
- 4- To ensure stability in a multiple unit modular setup, the minimum load applied on the bearing bridge must be similar to the total load applied on the cantilever bridges.
- 5- It is recommended that there be a **maximum** number of workers for each installation, calculated as follows: overall length of installation divided by 7' (2,1 m) and rounded **up**, **PLUS** two workers for each motorized unit in the installation, with at least one of those two workers being a qualified user/operator for an M2 Series motorized unit and its accessories. For example, on a setup with an overall length of 108' (32,9 m), the calculation would be: $108' / 7'$ (or $32,9 \text{ m} / 2,1 \text{ m}$) rounded up to **16**, **PLUS two workers for each motorized unit** (in this case, two units) = **4**, resulting in a **maximum of 20 workers** for the installation, including **two qualified users/operators**. Refer to p. 5 of the *Performance and Safety Rules* section for the definition of a qualified user/operator.
- 6- The weight of each person working in a given area reduces the load capacity of that area.
- 7- **The load capacities charts stickers displayed on the motorized unit used in the setup will take precedence over the information included in this owner's manual.**
- 8- The load capacity for the unit is shown in the green box on the same line as the cantilever bridge chosen, both on single and multiple unit setups load capacity charts.
- 9- Multiple unit setups can be a combination of any cantilever bridge on one side with any bearing bridge shown on the charts. Exclusions are shown in red in the charts (see fig. 6.3, p. 82 and fig. 6.4, p. 83).
- 10- To calculate the load capacity of a standard, authorized multiple unit configuration that is not shown in the charts included in this manual, take the length of the bearing bridge to be installed and refer to the capacities of the bearing bridge in the chart that is longer and closest to it. For example, for a 48' (15 m) bearing bridge, the load capacities and positioning of a 52' (16 m) bearing bridge would be used.

WARNING



To ensure safety at all times on a mast climbing work platform system, bridges should not be loaded beyond their maximum rated weight capacities. In addition, to prevent a mast climbing work platform system from stalling because of an overload, maximum rated load capacities of the motorized unit(s) should be observed. Overloading a mast climbing work platform system could result in serious injury or death.

Make sure that there is never two workers standing on the same plank outrigger at the same time.

LEGEND



Motorized unit



5' (1,5 m) modular bridge assembly



10' (3 m) modular bridge assembly



6' (1,8 m) bearing bridge adapter



Length of bridge setup

Load Capacities

Single unit setups [14' (4,3 m) motorized unit] – Evenly distributed

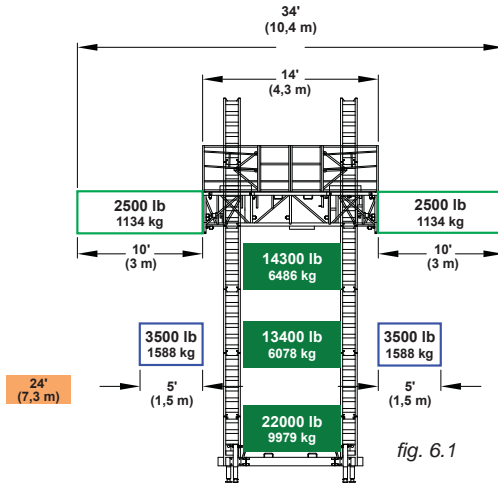

Single unit setups [24' (7,3 m) motorized unit] – Evenly distributed

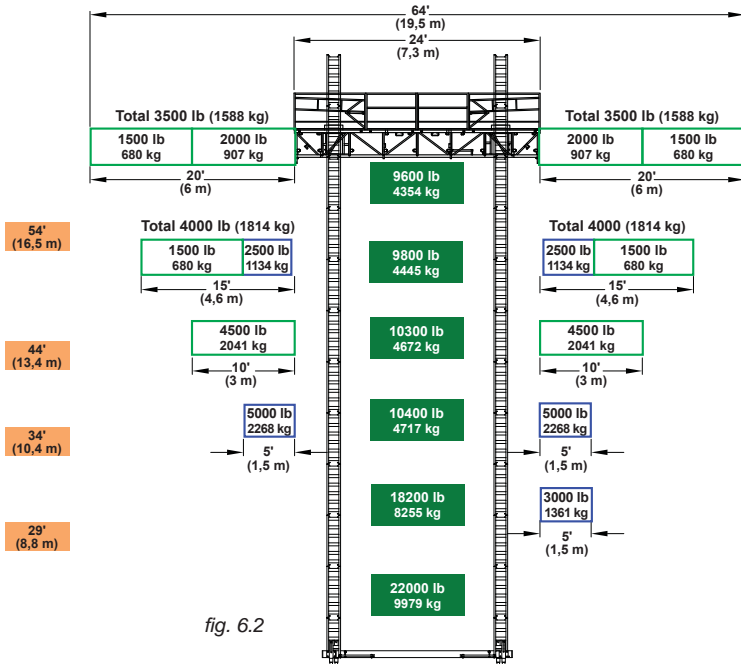

 To ensure safety at all times, refer to guidelines, warnings and legend on p. 80 for more information on load capacities. These load capacities charts apply to configurations using modular bridges or old-style bridges, as well as a combination of both.

Load Capacities

Multiple unit setups [14' (4,3 m) motorized units] – Evenly distributed

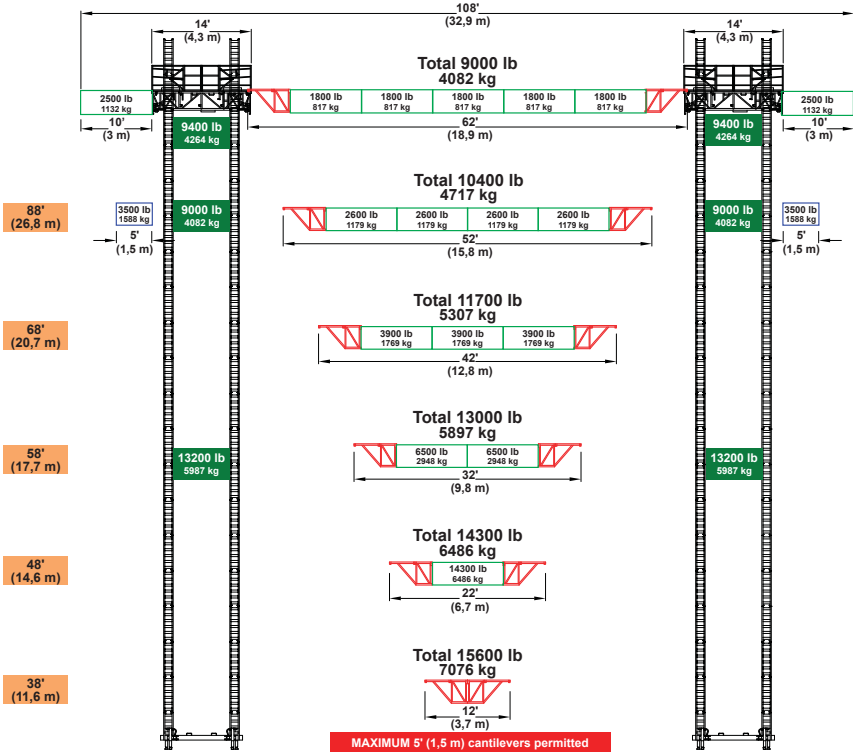

fig. 6.3

For point load configurations, contact the Hydro Mobile technical support team.

Calculating the maximum number of workers allowed on a given installation

Formula

Overall length of installation / 7' (2,1 m), rounded up
 +
 Two (2) workers per motorized unit in the installation

Calculation example for a 108' (32,9 m) installation

108' (32,9 m) / 7' (2,1 m), rounded up → 16
 +
 Two (2) workers for each motorized unit in the installation → 4
 Total of workers allowed on the installation → 20



To ensure safety at all times, refer to guidelines, warnings and legend on p. 80 for more information on load capacities. These load capacities charts apply to configurations using modular bridges or old-style bridges, as well as a combination of both.

Load Capacities

Multiple unit setups [24' (7,3 m) motorized units] – Evenly distributed

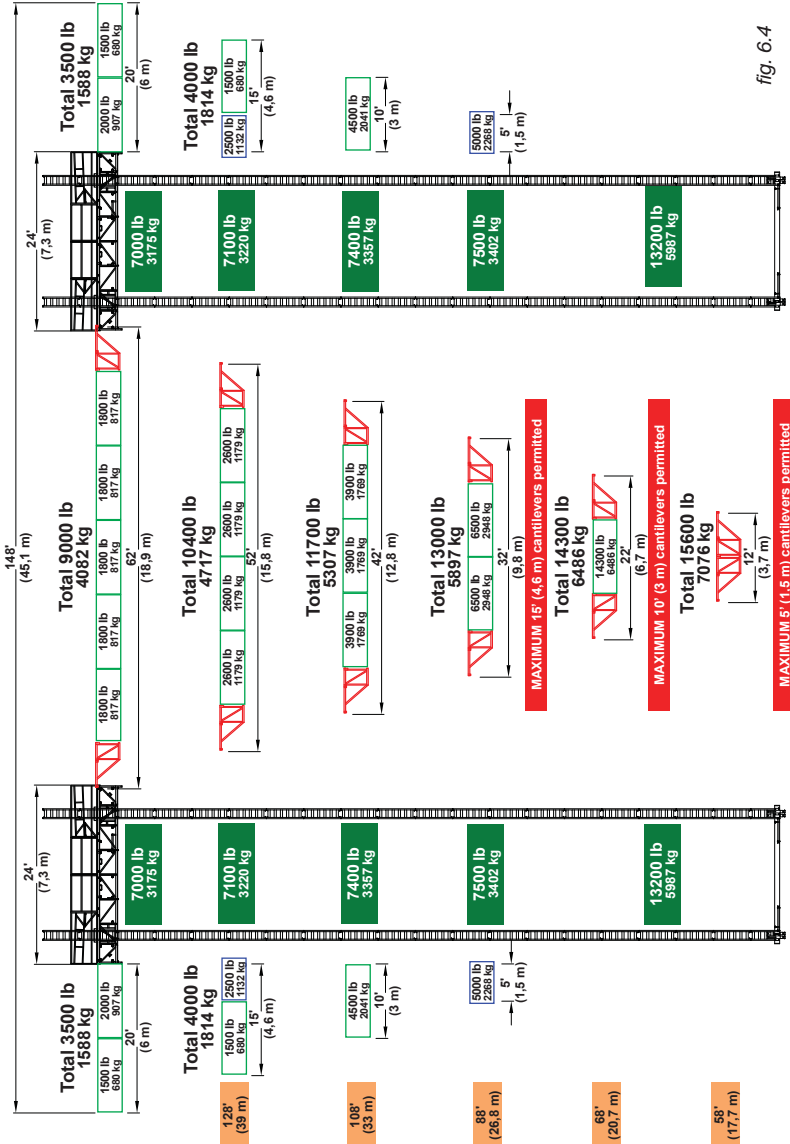

fig. 6.4

For point load configurations, contact the Hydro Mobile technical support team.

To ensure safety at all times, refer to guidelines, warnings and legend on p. 80 for more information on load capacities. These load capacities charts apply to configurations using modular bridges or old-style bridges, as well as a combination of both.

Load Capacities

Multi purpose insert bridge (MPI) – Evenly distributed
Lateral cantilever setups — with 24' (7,3 m) motorized unit

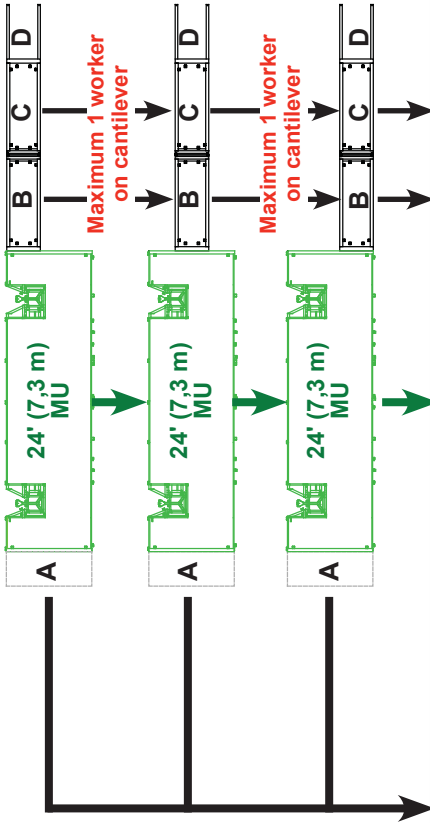

Any lateral or forward extension setup	A		MU 24' (7,3 m) Remaining capacity	Cantilever		Minimum length
	Bearing	Cantilever min.		Cantilever max.	B	
Any length of standard bearing bridge (for capacities, refer to bearing bridge load capacity charts)	No cantilever	5' (1,5 m)	10 400 lb (4717 kg)	2000 lb (907 kg)	not used	31' (9,4 m)
				5' (1,5 m)	10' (3 m)	500 lb (227 kg)

Maximum configuration of 3 planks at the end of the lateral cantilever, shown as "D" in the chart above.



To ensure safety at all times, refer to guidelines, warnings and legend on p. 80 for more information on load capacities. These load capacities charts apply to configurations using modular bridges or old-style bridges, as well as a combination of both.

fig. 6.5

Load Capacities

Multi purpose insert bridge (MPI) – Evenly distributed
Forward extension setups — with 24' (7,3 m) motorized unit

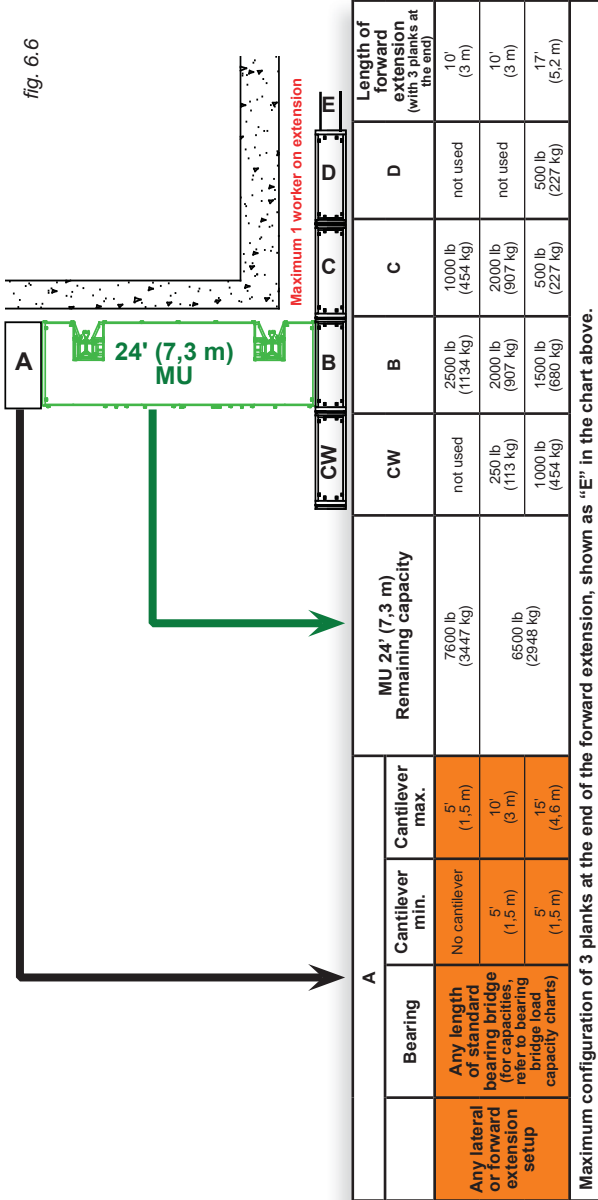

fig. 6.6

To ensure safety at all times, refer to guidelines, warnings, and legend on p. 80 for more information on load capacities. These load capacities charts apply to configurations using modular bridges or old-style bridges, as well as a combination of both.



Load Capacities

Multi purpose insert bridge (MPI) – Evenly distributed
Narrow bearing bridge setups — with 24' (7,3 m) motorized unit

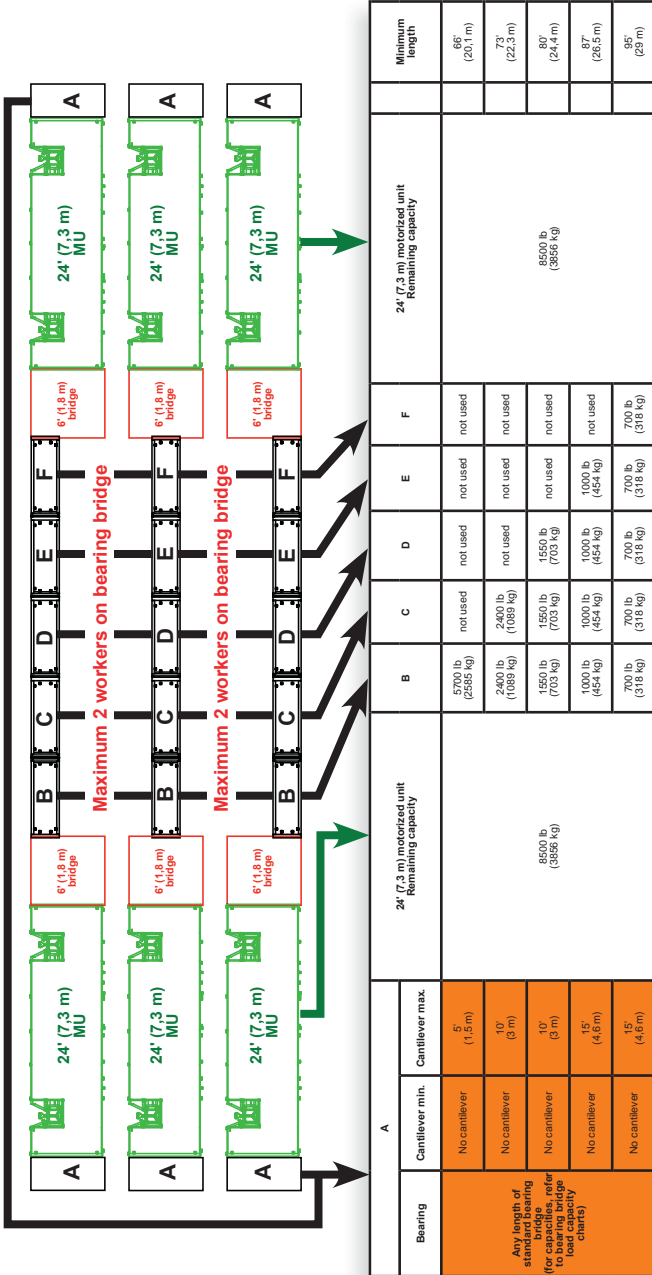

fig. 6.7



WARNING
Only configurations with maximum of three planks are allowed at all times. The configuration shown above are authorized for multi purpose bridges (MPI) with Serial number EXT02-134 and up ONLY. Special reinforcing kits must be used with MPI bridges having previous serial numbers. To ensure safety at all times, refer to guidelines, warnings and legend on p. 80 for more information on load capacities. These load capacities charts apply to configurations using modular bridges or old-style bridges, as well as a combination of both.

Load Capacities

Swivel bridge installation on a 24' (7,3 m) motorized unit
Single unit (Front 0-45 degrees)

At this end, it is mandatory to install a bridge. The only bridge configurations allowed are a cantilever bridge measuring **at least 5' (1,5 m)** and a **maximum of 10' (3 m)** with capacities as shown in the load capacities charts for single unit setups (see fig. 6.2, p. 81)

— OR —
any bearing bridge configuration shown in the load capacities charts for multiple unit setups (see fig. 6.3, p. 82)

— OR —
any swivel configuration shown on this load capacity chart.

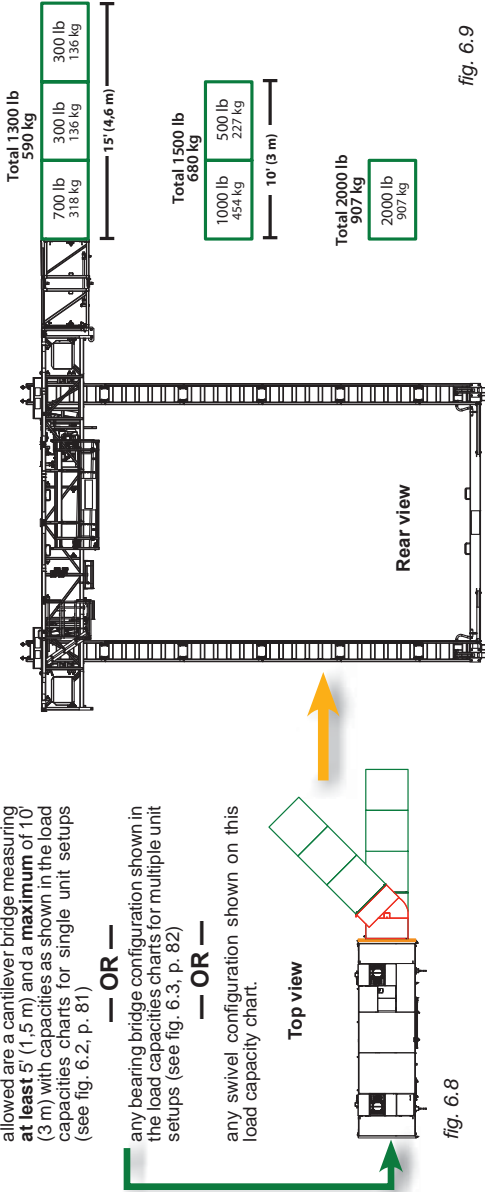
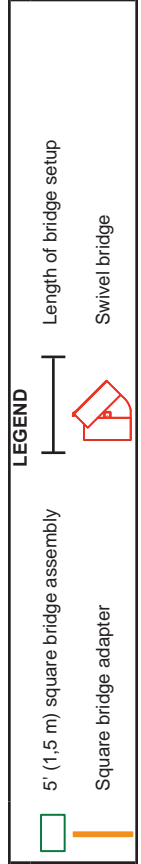



fig. 6.8

fig. 6.9



 To ensure safety at all times, refer to load calculation guidelines and warnings on p. 80.

Load Capacities

**Swivel bridge installation on a 24' (7,3 m) motorized unit
Single unit with counterweight adapter — Front 90 degrees**

At this end, it is mandatory to install a bridge. The only bridge configurations allowed are a cantilever bridge measuring **at least 5' (1,5 m)** and a **maximum of 10' (3 m)** with capacities as shown in the load capacities charts for single unit setups (see fig. 6.2, p. 81)

— OR —

any bearing bridge configuration shown in the load capacities charts for multiple unit setups (see fig. 6.3, p. 82).

NO OTHER CONFIGURATION THAN THOSE ABOVE ARE ALLOWED AT THIS END

fig. 6.12

CW	Load capacities for three bridges		
	A	B	C
300 lb (136 kg)	900 lb (408 kg) evenly distributed on three bridges — OR — 600 lb (272 kg) on one of the three bridges		
800 lb (363 kg)	1200 lb (544 kg) evenly distributed on three bridges — OR — 800 lb (363 kg) on one of the three bridges		
1100 lb (499 kg)	1400 lb (635 kg) evenly distributed on three bridges — OR — 950 lb (431 kg) on one of the three bridges		
1500 lb (680 kg)	1700 lb (771 kg) evenly distributed on three bridges — OR — 1150 lb (522 kg) on one of the three bridges		
1600 lb (726 kg)	1800 lb (816 kg) evenly distributed on three bridges — OR — 1200 lb (544 kg) on one of the three bridges		

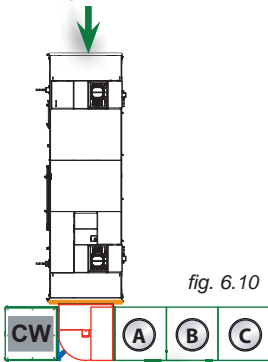

fig. 6.10

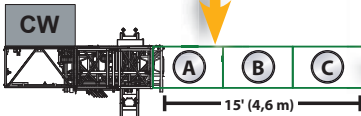
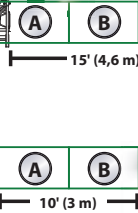

fig. 6.11

CW	Load capacities for two bridges	
	A	B
300 lb (136 kg)	1000 lb (453 kg)	1000 lb (453 kg)
500 lb (227 kg)	1500 lb (680 kg)	1000 lb (453 kg)
500 lb (227 kg)	2000 lb (907 kg)	750 lb (340 kg)
1000 lb (453 kg)	1500 lb (680 kg)	1250 lb (567 kg)
1000 lb (453 kg)	1950 lb (885 kg)	1000 lb (453 kg)

fig. 6.13



LEGEND

- 5' (1,5 m) square bridge assembly
- Square bridge adapter
- Counterweight adapter

- Length of bridge setup
- Swivel bridge
- CW Counterweight

To ensure safety at all times, refer to load calculation guidelines and warnings on p. 80.

Load Capacities

Angled and Corner Installations – Inside Corner with 24' (7,3 m) motorized units

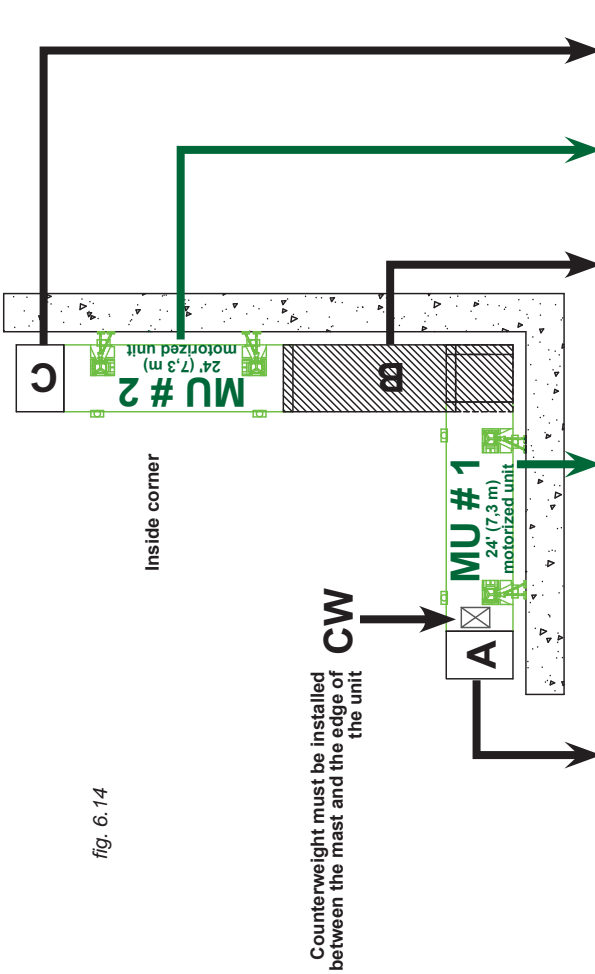

fig. 6.14

Counterweight must be installed between the mast and the edge of the unit

A		MU #1		B			MU #2	C
Cantilever length		Remaining capacity		Length	Capacity		Remaining capacity	Cantilever length
None			10,600 lb (4808 kg)	12' (3,7 m)	6800 lb (3084 kg)	11,500 lb (5216 kg)	Any cantilever as shown on fig. 6.4, p. 83	
CW = 1000 lb (454 kg)	5' (1,5 m)	No CW	Capacities as shown on fig. 6.4, p. 83	22' (6,7 m)	5400 lb (2449 kg)			
	10' (3 m)	No CW		32' (9,8 m)	4000 lb (1814 kg)			
	15' (4,6 m)	No CW	Capacities as shown on fig. 6.4, p. 83					
	20' (6,1 m)	No CW		Capacities as shown on fig. 6.4, p. 83				

Load Capacities

Angled and Corner Installations – Outside Corner with 24' (7,3 m) motorized units

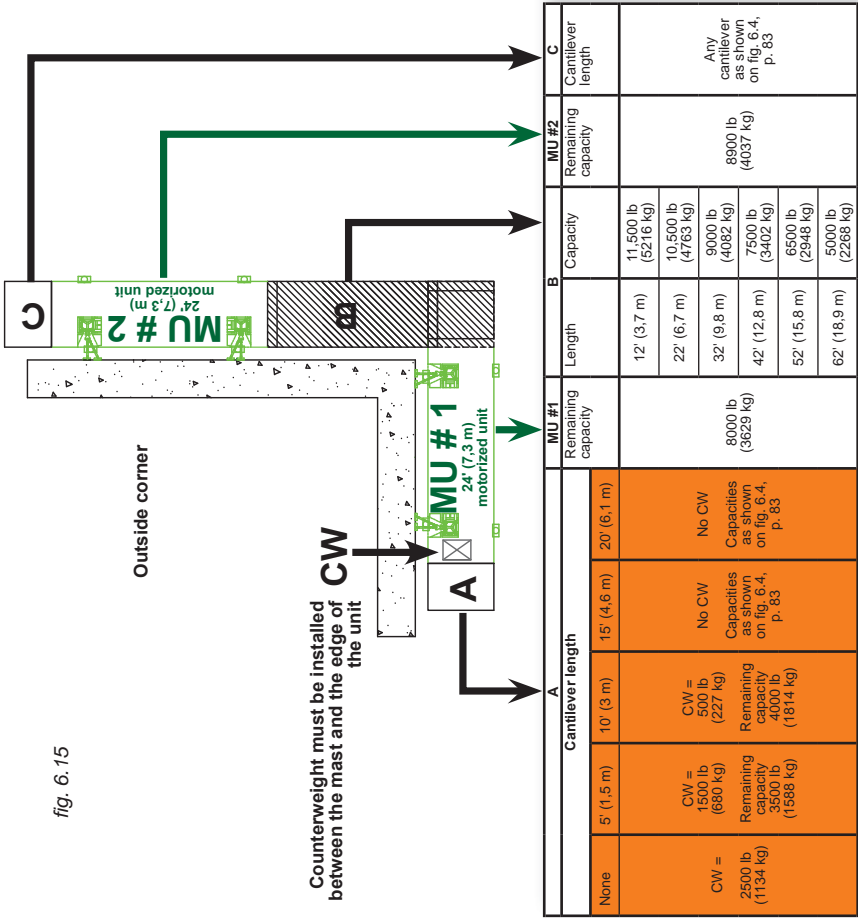

fig. 6.15

Safety Accessories

SAFETY comes first. While most hazards that may occur when operating an M2 Series motorized unit setup can be avoided by using extreme care and common sense, the use of safety accessories, such as a rest platform and appropriate guardrails and plank support outriggers, is recommended when areas and activities involve heights or positioning of the setup that put workers at risk.

Guardrails

In all cases where workers are exposed to fall hazards greater than specified by local regulations, the installation of appropriate guardrails is **mandatory** to ensure safety.

Installation of standard bridge guardrails

- 1- Slide the guardrail legs in the guardrail pockets at the top of the motorized unit or the bridge (fig. 7.1).
- 2- To secure the guardrail in place, tighten the bolt in each guardrail pocket to a torque of 30 lb-ft (41 N-m).
- 3- Install as many guardrails as is required by the setup.

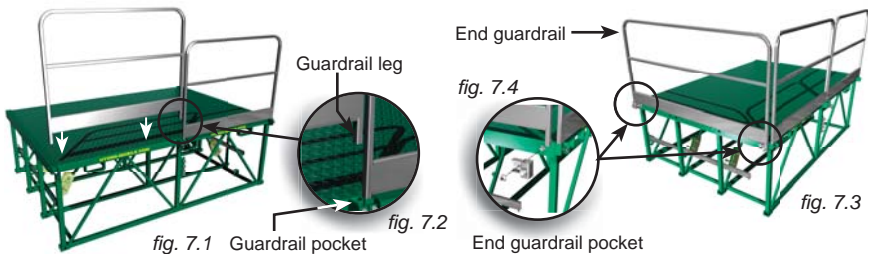

Installation of end guardrails

- 1- Align an end guardrail pocket with an outer assembly socket at one end of the motorized unit or the bridge (fig. 7.3). Secure in place with a 1" x 2" long (GR5) bridge bolt assembly.
- 2- Repeat step 1 to install the second end guardrail pocket in the opposite corner.
- 3- Slide the guardrail legs in the end guardrail pockets (fig. 7.4).
- 4- To secure the end guardrail in place, tighten the bolt in each guardrail pocket to a torque of 30 lb-ft (41 N-m).
- 5- Install as many end guardrails as is required by the setup.

Face Guardrail Supports (optional)

Face guardrail supports must be installed when the distance between the end of planking (or deck, if not using planks) and the structure is greater than what local regulations allow or 6" (15 cm) (ex. recess in a wall, end of a building, etc.), the most stringent of conditions taking precedence over the others. On all M2 Series motorized units and bridges, the face guardrail supports can be installed at the **bottom** or **top** outrigger position.



fig. 7.5

Installation

- 1- If there are no outriggers installed, install the outriggers at the top or bottom position, as required. Refer to p. 95 for instructions on the installation of outriggers. Make sure not to install any plank stop pins. If outriggers are already installed, remove the plank stop pins and proceed to step 2.

Safety Accessories

Guardrails

Installation

- 2- Slide the face guardrail support over the outrigger tube.
- 3- Secure in place by sliding a clevis pin through the face guardrail support and the outrigger. Secure the support in place with a hitch pin clip.

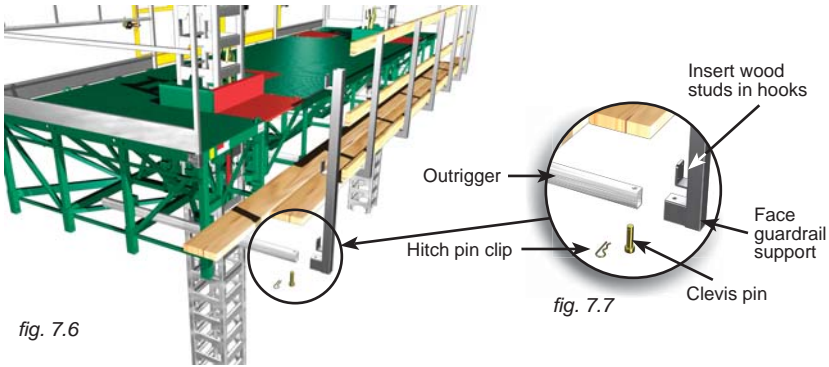

- 4- Repeat steps 2 and 3 for each guardrail face support required to secure the hazardous opening.
- 5- Insert wood studs in the hooks of each face guardrail support to cover the hazardous opening (fig. 7.6). It is important to make sure to use 2" x 6" (5 cm x 5 cm) wood studs at the bottom position. Secure the studs in place with nails or screws.



WARNING

It is important to make to use 2" x 6" (5 cm x 5 cm) wood studs at the bottom position.

Plank-End Guardrails

Plank-end guardrails must be installed at the ends of planking as fall protection. In a two-plank configuration, the opening must be closed by placing one plank-end guardrail over two planks.

Installation

- 1- Slide the bottom end of the plank-end guardrail over the end of two planks.
- 2- Drive one or two nails or screws into the planks through the top plate to secure the guardrail in place.
- 3- A three-plank configuration will require the installation of two plank-end guardrails. Follow steps 1 and 2 to install the first plank-end guardrail.
- 4- Slide a second plank-end guardrail second guardrail backwards over the end of two planks, overlapping the first one installed. Secure the second guardrail in place as described in step 2.



Note: Two plank-end guardrails face to face are shown above

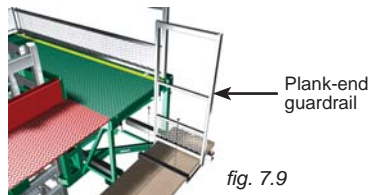

Safety Accessories

Guardrails

Movable Guardrails (optional)

To ensure the safety of workers in a more flexible way, movable guardrails may be installed on bridges. Install standard guardrails and secure the movable guardrail to the standard guardrails with toggle pins (as shown in fig. 7.10). Refer to p. 91 for instructions on the installation of standard guardrails. The small section of the movable guardrail ("B" in fig. 7.10) can be installed at either end of the main section ("A" in fig. 7.10).

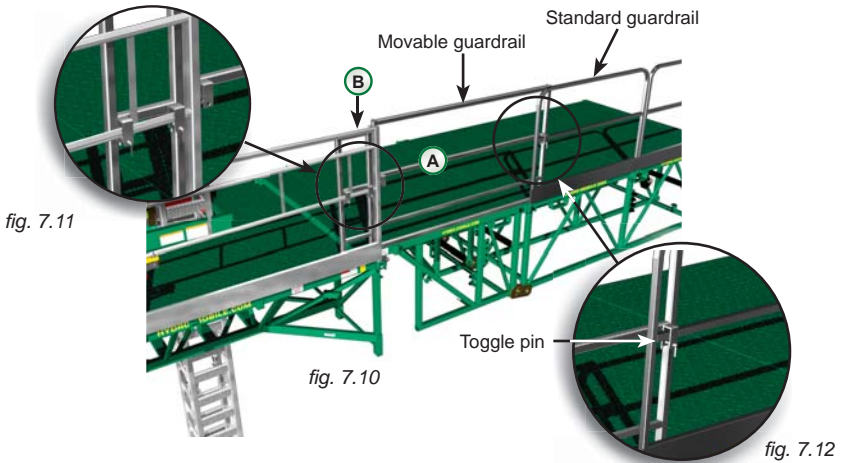

WARNING

A movable guardrail cannot be used as a tie-off point.

Universal Plank Safety Support (optional)

The universal plank safety support is installed at the extremities of planking to prevent planks from lifting, tipping and slipping.

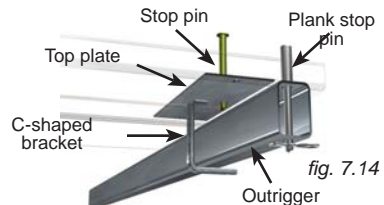
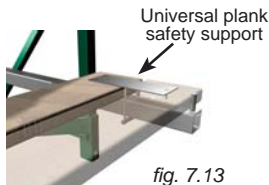

Installation

- 1- Remove the stop pin (fig. 7.14) and slide the plank safety support between two planks.
- 2- Secure the C-shaped plank safety support around the outrigger and replace the stop pin.
- 3- Using screws or nails, secure the top plate of the plank safety support to the planks (fig. 7.13).

Safety Accessories

Retractable Rest Platform (optional)

The use of an automatically retractable rest platform is recommended to reach work areas at heights between 30' and 69' (9 m and 21 m). It is not recommended to climb up the mast to reach work areas at heights over 69' (21 m) because of the time and effort required to reach such heights. The use of alternate equipment compliant with local regulations, such as a rapid mast climber, a transport platform system, or a conventional scaffold stair system will prove to be more efficient. Refer to local regulations for more information.

It is recommended to inspect the rest platform before every working shift to make sure it is clean and in good working condition.

Installation

- 1- For safety reasons, it is recommended that the rest platform be installed from the platform of the motorized unit or from a man basket underneath the motorized unit. The rest platform must be installed on the back side of the mast, when the platform of the motorized unit has been raised to more than 30' (9 m) from base level.
- 2- Remove the 3/8" nuts and bolts from the folder part (fig. 7.17).
- 3- Unfold the rest platform and leave the handle on top.
- 4- Slide the rest platform inside the mast with its rectangular step resting against the back side of the mast (fig. 7.16).
- 5- Install the folder part on a rung facing the wall using 3/8" bolts and nuts.
- 6- Let the rest platform retract slowly inside the mast.
- 7- Remove the 3/8" bolt and nut from the handle.
- 8- Install the handle 5 rungs above the rest platform (fig. 7.18). Fasten with the 3/8" bolt and nut.
- 9- Test the rest platform by raising the handle. Doing so will retrieve the rest platform from inside the mast. When the handle is released the rest platform will fold and retract inside the mast.
- 10- If the rest platform unfolds and retracts as and when it should, it is safe to use the rest platform.

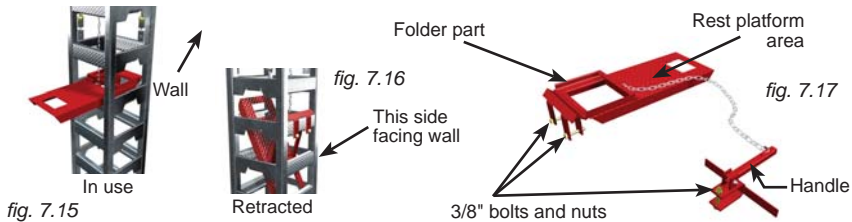

Using the retractable rest platform

- 1- Climb up the mast until one step above the rest platform.
- 2- Raise the handle to a vertical position to retrieve the rest platform from inside the mast.
- 3- Step on the rest platform only when the handle is in a vertical position.
- 4- Once on the rest platform, release the handle.
- 5- Resuming the climb up the mast will make the rest platform retract into the mast automatically.



Outriggers

M2 Series motorized units and bridges are shipped with outriggers that may be used at the top or bottom position.

Plank support outriggers must be installed 5' (1,5 m) from one another. The 72" (183 cm) outrigger, installed at the bottom position close to the walkway assembly, **must not be replaced** by any other outrigger. Installing any outrigger other than the 72" (183 cm) outrigger in front of the walkway will lead to damages to the walkway assembly and could lead to injuries.

The size and number of outriggers required will vary according to the planking configuration. Planking configurations of five to eight planks will require the use of additional, optional components such as longer outriggers and cross boxes. Refer to the *Outrigger Selection* table (fig. 7.19) for more information about the size and number of outriggers required for each planking configuration. Refer also to p. 96 for more information on the installation and use of doubled outriggers.

For any outrigger configuration other than those described in this owner's manual, contact the Hydro Mobile technical support team.

Planking configurations

OUTRIGGER SELECTION TABLE		
Planking configuration	Outrigger size	
0 to 4 planks	2 1/2" x 1 1/2" x 3/16" x 72" (6,4 cm x 3,8 cm x 0,5 cm x 183 cm) (standard outrigger, as provided with unit or bridge)	SINGLE
5 planks *	2 1/2" x 1 1/2" x 1/4" x 84" (6,4 cm x 3,8 cm x 0,6 cm x 213 cm)	SINGLE
6 planks *	2 1/2" x 1 1/2" x 1/4" x 120" (6,4 cm x 3,8 cm x 0,6 cm x 305 cm)	DOUBLED
7 planks *	2 1/2" x 1 1/2" x 1/4" x 120" (6,4 cm x 3,8 cm x 0,6 cm x 305 cm)	DOUBLED
8 planks *	2 1/2" x 1 1/2" x 1/4" x 120" (6,4 cm x 3,8 cm x 0,6 cm x 305 cm)	DOUBLED

* Refer to the planking configuration guidelines for more information.

fig. 7.19

Planking configuration guidelines

PLANKING CONFIGURATIONS – WIDTH ALLOWED ON INSTALLATION			
Number of planks	Motorized unit	Bearing bridge	Cantilever bridge(s)
0 to 4 planks	100% of total width	100% of total width	100% of total width
5 to 8 planks	100% of total width	50% of total width	Max width 5' (1,5 m)

fig. 7.20

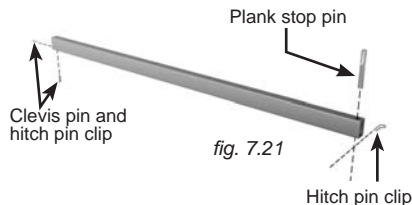

fig. 7.21



WARNING

The 72" (183 cm) outrigger installed close to the walkway assembly must not be replaced by any other outrigger

Outriggers

Doubled outriggers (optional)

Planking configurations of six to eight planks wide require the use of doubled outriggers and optional cross boxes. For more information about the installation and use of optional cross boxes, refer to p. 97 of this section. Refer to the *Outrigger Selection* table (fig. 7.19, p. 95) for more information on the outrigger size required for each planking configuration.

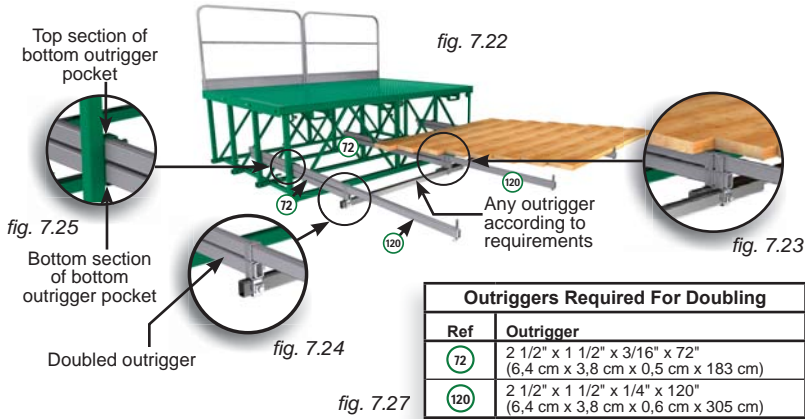

Installation

- 1- Remove the hitch pin clip and the clevis pin (fig. 7.21, p. 95) and slide one outrigger in the **top section** of the bottom outrigger pockets (fig. 7.25) on the motorized unit or the bridge.
- 2- Slide the **top section** of a cross box (fig. 7.26, p. 96) on the outrigger until it is about halfway through (fig. 7.22). Slide the **top section** of a second cross box on the end of the outrigger (fig. 7.24). Tighten the bolt on the cross boxes by hand only to hold them in place.
- 4- Slide the second outrigger into the **bottom section** of the bottom outrigger pockets (fig. 7.25) and the **middle section** of the cross box (fig. 7.26, p. 96) until its end is pushed in by about 6" (15 cm) from the end of the top outrigger.

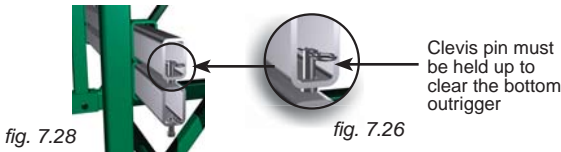

- 5- Insert the clevis pin into the top outrigger (fig. 7.27) and pull it up until its head is snug against the outrigger.
- 6- Still holding up the clevis pin on the top outrigger, pull out the bottom outrigger until both outriggers are even (fig. 7.28). Secure the clevis pin on the top outrigger with a hitch pin clip. Insert a clevis pin in the bottom outrigger and secure it in place with a hitch pin clip.
- 7- Tighten the bolts on all the outrigger pockets and on the top and middle sections of the cross boxes to a torque of 30 lb-ft (41 N-m).
- 8- Repeat steps 1 through 7 for each doubled outrigger required.
- 9- Slide a cross outrigger through the bottom section of the cross boxes on the end of the doubled outriggers (fig. 7.22 and fig. 7.23). Secure in place by tightening the bottom bolt on the cross boxes to a torque of 30 lb-ft (41 N-m).

Outriggers

Cross Boxes (optional)

Cross boxes are used to install auxiliary outriggers, as required when planking the inside corner of a forward extension or the recessed area in a wall. Cross boxes are also used when doubling outriggers is required.

Installation

- 1- Remove the clevis pin, hitch pin clip and plank stop pin (fig. 7.21, p. 95) from two outriggers.
- 2- Slide a cross box on the back and the front of each of the two outriggers (fig. 7.29). Replace the clevis pin, hitch pin clip and plank stop pin on each outrigger and tighten the pocket bolts on both outriggers.

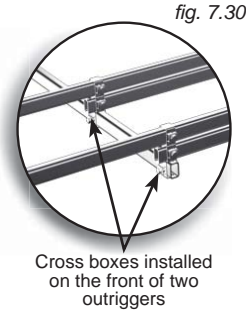
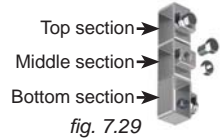

- 3- Slide the cross outriggers through the cross boxes until they are halfway through.
- 4- Install a cross box on each cross outrigger and extend each outrigger in position.
- 5- Slide auxiliary outriggers through the cross boxes on the cross outriggers until they are in position. Secure them in place with a clevis pin and a hitch pin clip. Install a plank stop pin in each of the auxiliary outriggers.
- 6- Once the planks are in place, adjust the auxiliary outriggers until the plank stop pins rest snugly against the planks.
- 7- Secure the outriggers in place by tightening all the bolts on the cross boxes to a torque of 30 lb-ft (41 N-m).

Non Standard Planking Configurations

Special planking configurations may be required according to job site requirements, to install planking in areas not covered by standard planking. **Only the following three non standard planking configurations are allowed.** The following planking configurations will require the use of optional cross boxes and, in some cases, optional 120" (305 cm) outriggers. It is mandatory to install the cross boxes as close to the bridge outrigger pockets as possible.

Non Standard Planking Configuration #1

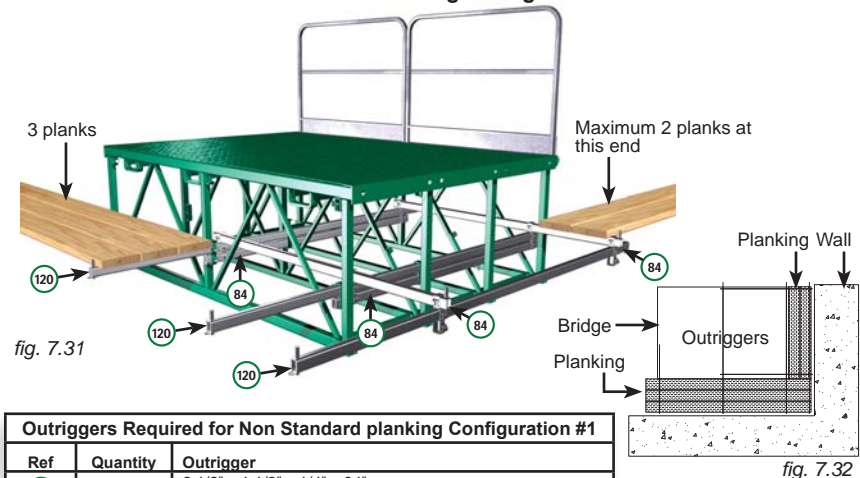

Outriggers Required for Non Standard planking Configuration #1		
Ref	Quantity	Outrigger
84	4	2 1/2" x 1 1/2" x 1/4" x 84" (6,4 cm x 3,8 cm x 0,6 cm x 213 cm)
120	3	2 1/2" x 1 1/2" x 1/4" x 120" (6,4 cm x 3,8 cm x 0,6 cm x 305 cm)

fig. 7.33

Outriggers

Non Standard Planking Configurations

Non Standard Planking Configuration #2

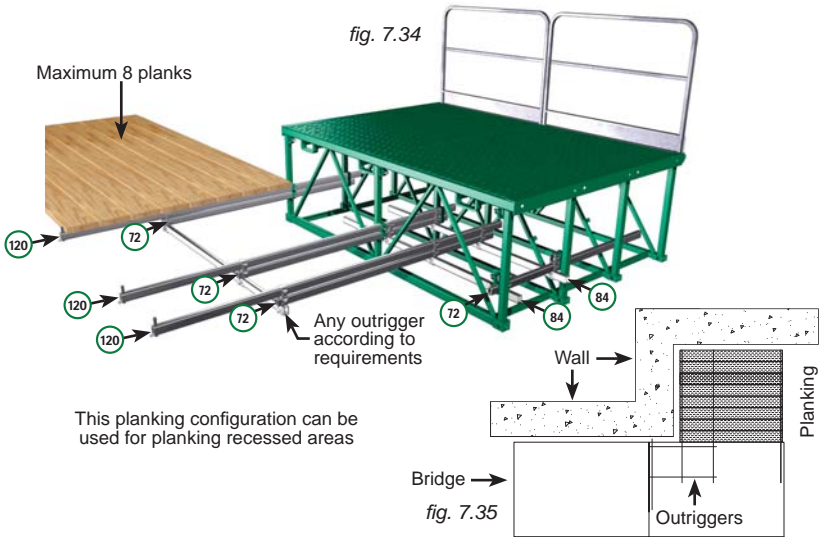

This planking configuration can be used for planking recessed areas

Outriggers Required for Non Standard planking Configuration #2		
Ref	Quantity	Outrigger
72	4	2 1/2" x 1 1/2" x 3/16" x 72" (6,4 cm x 3,8 cm x 0,5 cm x 183 cm)
84	2	2 1/2" x 1 1/2" x 1/4" x 84" (6,4 cm x 3,8 cm x 0,6 cm x 213 cm)
120	3	2 1/2" x 1 1/2" x 1/4" x 120" (6,4 cm x 3,8 cm x 0,6 cm x 305 cm)

fig. 7.36

Non Standard Planking Configuration #3

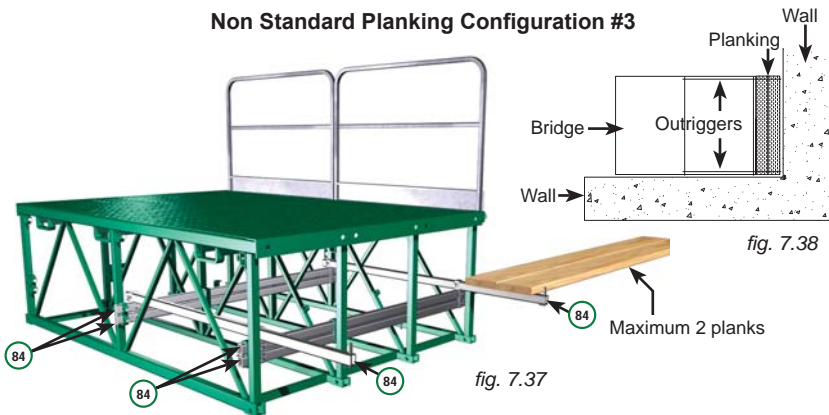

Outriggers Required for Non Standard planking Configuration #3		
Ref	Quantity	Outrigger
84	6	2 1/2" x 1 1/2" x 1/4" x 84" (6,4 cm x 3,8 cm x 0,6 cm x 213 cm)

fig. 7.39

Outriggers

Top outriggers (optional)

Outriggers used at the top position can be inserted either from the **front** or the **back** of the motorized unit or the bridge.

In a configuration where 72" (183 cm) outriggers are used at the **top** position only, the maximum width of planking allowed is **four** planks. In a configuration where 72" (183 cm) outriggers are used at both the **top** and **bottom** position (fig. 7.2), the maximum width of planking allowed at the **top** position is **two** planks. Refer to the outrigger selection table and the planking configuration guidelines for more information.

Each outrigger installed at the top position has a maximum capacity of 265 lb (120 kg) and can be used for workers and material.

Installation

- 1- Remove the hitch pin clip, the clevis pin and the plank stop pin (fig. 7.21, p. 95) and slide the outrigger in the top outrigger pockets on the motorized unit or the bridge, leaving no more than 21" (53,3 cm) protruding from the structure if bottom outriggers are installed, or no more than 41" (104 cm) if there are no bottom outriggers installed. Replace the hitch pin clip, the clevis pin and the plank stop pin.
- 2- Once the planks are in place, push in the outrigger until the plank stop pin rests snugly against the planks.
- 3- Secure the outrigger in place by tightening the outrigger pocket bolts to a torque of 30 lb-ft (41 N-m).



The outrigger configuration shown in fig. 7.40 requires the use of additional outriggers not factory-provided with M2 Series bridges and units.

Bottom outriggers

Outriggers used at the bottom position can be inserted either from the **front** or the **back** of the motorized unit or the bridge. Each outrigger at the bottom position can be used by **workers only** (including personal tools and equipment). The bottom outriggers **cannot be used** to store material, tools, equipment or to support any other load. In a configuration where 72" (1,8 cm) outriggers are used at the **bottom** position, the maximum width of planking allowed is **four** planks. Refer to the *Outrigger Selection* table on p. 95 and to the planking configuration guidelines on p. 95 for more information.

Installation

- 1- Remove the hitch pin clip, the clevis pin and the plank stop pin (fig. 7.21, p. 95). Slide the outrigger in the bottom outrigger pockets on the motorized unit or the bridge, leaving no more than 41" (104 cm) protruding from the structure. Replace the hitch pin clip, the clevis pin and the plank stop pin.
- 2- Once the planks are in place, push in the outrigger until the plank stop pin rests snugly against the planks.
- 3- Secure the outrigger in place by tightening the outrigger pocket bolt to a torque of 30 lb-ft (41 N-m).

Cantilever Outrigger Supports (optional)

In a cantilever installation, it is possible to install cantilever outrigger supports at the ends of the cantilever bridges on both sides of the mast to complete the installation of planking on bottom outriggers along the entire length of the setup, if necessary. The **maximum width** of planking allowed on bottom outriggers is **four planks**.

Installation

- 1- Align and insert the top tube of the cantilever outrigger support into the end tube of the bridge. Push in the support as far as possible.
- 2- Lift up the U-bracket and hold it up against the end tube of the bridge, making sure the holes align properly. Secure the U-bracket in place by sliding a clevis pin through the holes and locking it with a hitch pin clip.
- 3- Insert a 72" (183 cm) outrigger in the bottom tube of the cantilever outrigger support and tighten the tube bolt slightly.
- 4- Once the planking is installed (maximum four planks wide), install a plank stop pin in the outrigger on the cantilever support. Push the outrigger in until it is snug against the planking and tighten the tube bolt properly to secure the outrigger in place.



Sliding Doors

Two sliding doors allow the safe loading and unloading of materials and equipment onto M2 Series motorized units.

Installation

- 1- Retrieve the sliding doors and the door support guardrails from their storage location on the motorized unit (fig. 7.42).



Note: Items depicted in illustrations may differ from actual products.

Sliding Doors

Installation (cont'd)

- 2- Install the two door support guardrails (84" or 213 cm) at each end of the back of the motorized unit, making sure that their mid rail tubes are slanting **toward** the opening (fig. 7.43). For instructions on the installation and use of guardrails, refer to p. 91 of this section.



Door support guardrail

fig. 7.43



fig. 7.44

Bottom guide wheel

Sliding door

- 3- Take the left sliding door. Loosen the top and bottom nuts on the short threaded rod (fig. 7.46) on the bottom guide wheel. Lower the guide wheel completely.
- 4- Insert the left sliding door on the left door support guardrail, making sure the top guide wheel is engaged on the top mid rail tube (fig. 7.43).

fig. 7.45

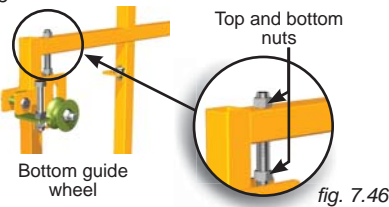

Bottom guide wheel

Top and bottom nuts

fig. 7.46

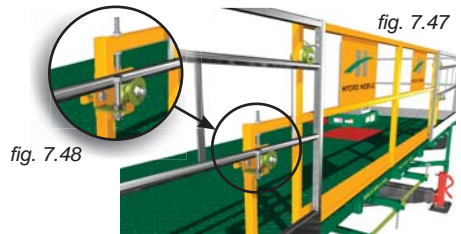

fig. 7.48

fig. 7.47

- 5- Tighten the top nut on the short threaded rod to adjust the height of the guide wheel until the door is parallel to the deck. Secure the door in place by tightening the bottom nut.
- 6- Repeat steps 3 through 5 to install the right sliding door.
- 7- To open the sliding doors, lift each door enough so that it clears the gate latch and slide it open (fig. 7.49).

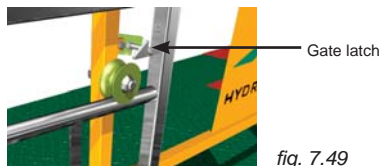

fig. 7.49

**WARNING**

Sliding doors must not be used to tie a lifeline.

**WARNING**

To ensure safety and avoid mishaps, it is important to make sure each sliding door is properly latched when closed.

Wheel Set (optional)

The optional M2 Series wheel set facilitates the relocation of a motorized unit. The wheel set can also be used to move a cantilever setup measuring up to 64' (19,5 m) or a bearing bridge structure of a length of up to 62' (18,9 m). On job sites where space is limited, the wheel set can be unlocked and set in a "crab mode" to enable steering with the two-part tongue. It is important to use extreme care when lifting and moving a motorized unit or a setup with the wheel set.

Installation on a motorized unit

- 1- Remove all loads and equipment from the deck and make sure there are no bridges bolted to the motorized unit. Make sure all doors and guardrails are secure and that there is no one on the platform.
- 2- Make sure that there is at least but not more than one mast section on top of each of the bottom mast sections welded on the base of the unit. Raise the motorized unit to the top of the mast sections. For instructions on how to raise or lower the motorized unit, refer to p. 65 and p. 67 of the *Power Pack and Operating Components* section.
- 3- Using the handle bars, move the wheel set under one end of the motorized unit. Make sure the wheel set is positioned under a vertical member.
- 4- Lower the motorized unit onto the wheel set with precaution, making sure the deck of the motorized unit remains level.
- 5- Secure the wheel set in place with the four locking pins.
- 6- Slide chains, cable or slings through the other end of the motorized unit and secure them crosswise to the forks of a rough terrain forklift, making sure the deck of the motorized unit remains level. Refer to p. 37 of the *Motorized Unit* section for instructions on the lifting and moving of a motorized unit.
- 7- Make sure both cylinders are fully retracted and that the hooks are not engaged on a mast rung. For more information on how to make the cylinders retract themselves, refer to step 4 of the instructions for raising a motorized unit on p. 65 of the *Power Pack and Operating Components* section.
- 8- Retrieve the transport hooks from their storage location. Remove the cylinder hooks and install the transport hooks. Store the cylinder hooks in their storage location. For more information, refer to p. 62 of the *Power Pack and Operating Components* section.
- 9- Make sure the secondary hooks are not engaged on a mast rung. Proceed with caution and extend the cylinders to raise the base off the ground by about 12" (30,5 cm).
- 10- Retrieve the mast locking bars from their storage location and insert them in the masts. Refer to p. 62 of the *Power Pack and Operating Components* for instructions on the storage of locking bars. Lower the motorized unit until the base rests on the mast locking bars. Raise the base jacks, if necessary.
- 11- Move the motorized unit like a trailer to its new location. For more information about the lifting and moving of a motorized unit, refer to p. 37 of the *Motorized Unit* section.

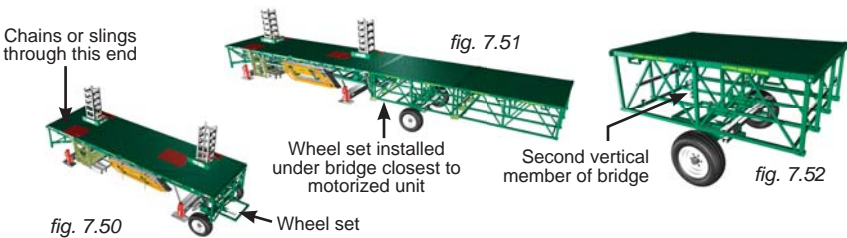

Installation on a cantilever setup

- 1- Follow steps 1 and 2 of the instructions for the installation of the wheel set on a motorized unit.
- 2- Using the handle bars, move the wheel set under the bridge at one end of the cantilever setup. Make sure the wheel set is positioned under a vertical member.

Wheel Set

Installation on a cantilever setup (cont'd)

- 3- Follow steps 4 through 10 of the instructions for the installation of the wheel set on a motorized unit.
- 4- Move the cantilever setup like a trailer to its new location. For more information about the lifting and moving of a cantilever setup, refer to p. 37 of the *Motorized Unit* section.

Installation on a bearing bridge setup

- 1- Make sure the bearing bridge structure is not attached to any motorized unit.
- 2- Follow steps 1 and 2 of the instructions for the installation of the wheel set on a motorized unit, on p. 102.
- 3- Using the handle bars, move the wheel set under the bridge at one end of the bearing bridge structure. Make sure the wheel set is positioned under a vertical member.
- 4- Proceed with steps 4 through 10 of the instructions for the installation of the wheel set on a motorized unit.
- 5- Move the bearing bridge structure like a trailer to its new location (fig. 7.50, p. 102). For more information about the lifting and moving of a bearing bridge structure, refer to p. 37 of the *Motorized Unit* section.

Hoist (optional)

Designed to fit M2 Series motorized units, the hoist system is used to supply material on the work platform. With a nominal capacity of 4000 lb (1815 kg) and equipped with 250' (76 m) of cable, the hoist can lift and handle large bulks of material such as full pallets of blocks or bricks.

The hoist power pack must be installed in the rack mounting pockets on the **right side** of the motorized unit (fig. 7.53). The installation of the hoist engine on a 14' (4,3 m) motorized unit will require the use of the rack adapter (fig. 7.54).

It is important to note that the weight of the hoist system and its components totals 2500 lb (1134 kg) and that this weight must be deducted from the load capacities of the setup. Refer to the *Load Capacities* section on p. 80 to avoid overloading the platform. For instructions on the installation, use and specifications of the hoist system, refer to the Hoist System owner's manual.

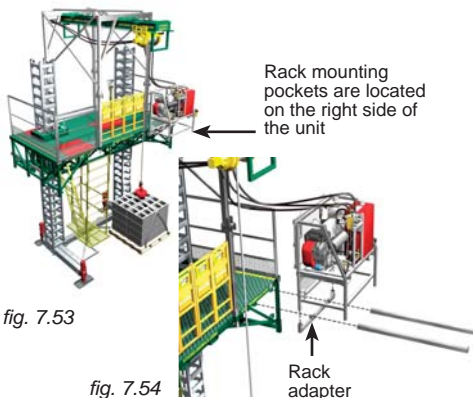

Weather Protection (optional)

The weather protection system can increase work efficiency by protecting workers, material and equipment against adverse climatic conditions. A structure using a combination of steel and wood allows users to fasten tarpaulins quickly. A lower structure can also be installed to cover up to 7' (2,1 m) of wall underneath the platform as an additional protection against cold weather conditions. The weight of the weather protection structure and its accessories must be deducted from the load capacities of the setup. Refer to the *Load Capacities* section on p. 80 for more information.

Installation of the bottom support structure

- 1- With the motorized unit at base level, slide a bottom support assembly under the motorized unit or the bridge (fig. 7.57). Hook the clamp-end tubes (fig. 7.56) on the deck.
- 2- Slide a taper pin from right to left in each clamp-end tube and secure in place with a hitch pin clip. Secure each grip end tube to the deck by tightening the bolt at the bottom (fig. 7.57).
- 3- Install as many bottom support assemblies as is required by the setup. The distance between two bottom supports must not exceed 8' (2,4 m).

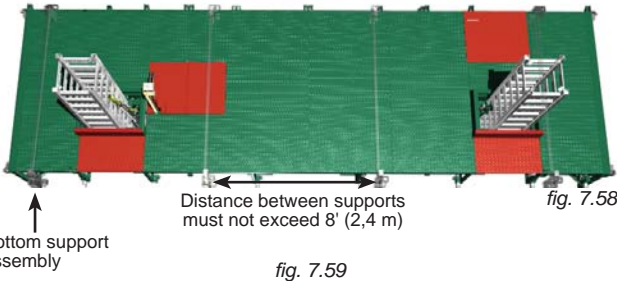
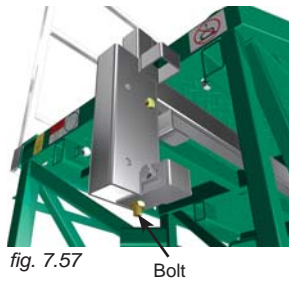
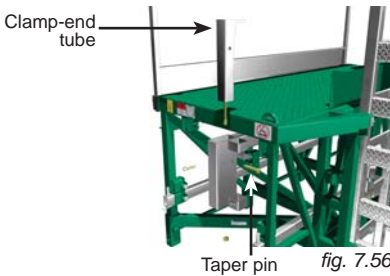

fig. 7.59



Installation of the top support structure

- 1- Insert a vertical post into the rear bottom support bracket (fig. 7.60, p. 105). The diagonal brace on the vertical post must be turned **toward** the face of the work (fig. 7.61, p. 105).

Weather Protection

Installation of the top support structure (cont'd)

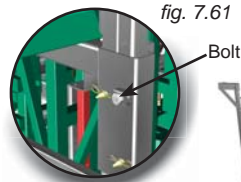
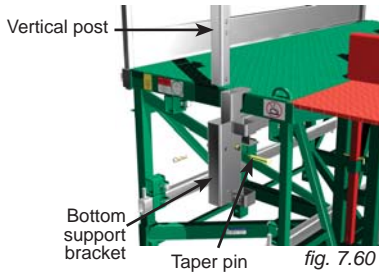
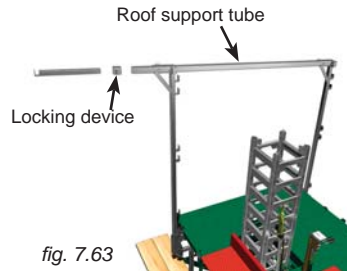
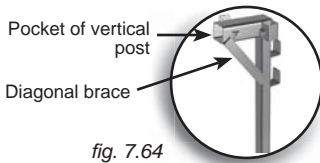

fig. 7.62



Diagonal brace of post facing toward face of work

- 2- Slide a taper pin through the **second lowest** adjustment hole in the vertical tube and secure it in place with a hitch pin clip (fig. 7.60).
- 3- Tighten the bolt on the bottom support bracket (fig. 7.61).
- 4- Insert a front vertical post into the bottom support bracket (fig. 7.62). The diagonal brace on the vertical post must be turned **toward** the face of the work.
- 5- Slide a taper pin through the **lowest** adjustment hole in the vertical post and secure it in place with a hitch pin clip. The front vertical posts must be higher than the rear vertical posts.



- 6- Remove the locking device from a 10' (3 m) roof support tube (fig. 7.63). Slide the roof support tube into the pocket of the rear vertical post. Make sure that the holes at the end of the roof support tube are **toward** the face of the work.
- 7- Insert a sliding tube into the roof support tube (fig. 7.63).
- 8- Pull the roof and sliding tube assembly and slide it into the pocket of the front vertical post (fig. 7.64).
- 9- Tighten the pocket bolt on both vertical posts to secure the assembly in place.
- 10- Replace the locking device on the sliding tube, making sure the bolt is horizontal, aligned with the roof support tube and on the side opposite to the angle bracket located on the vertical post (fig. 7.68, p. 106). Adjust the sliding tube to bridge the distance to the face of the work and tighten the bolt to hold the sliding tube in place.
- 11- Install as many roof support tubes as is required by the setup.
- 12- Slide a 2" x 4" (5 cm x 10 cm) stud through the lateral angle brackets at the top of each vertical post. Measure and adjust the length of the plank to reach up the face of the work.

Weather Protection

Installation of the top support structure (cont'd)

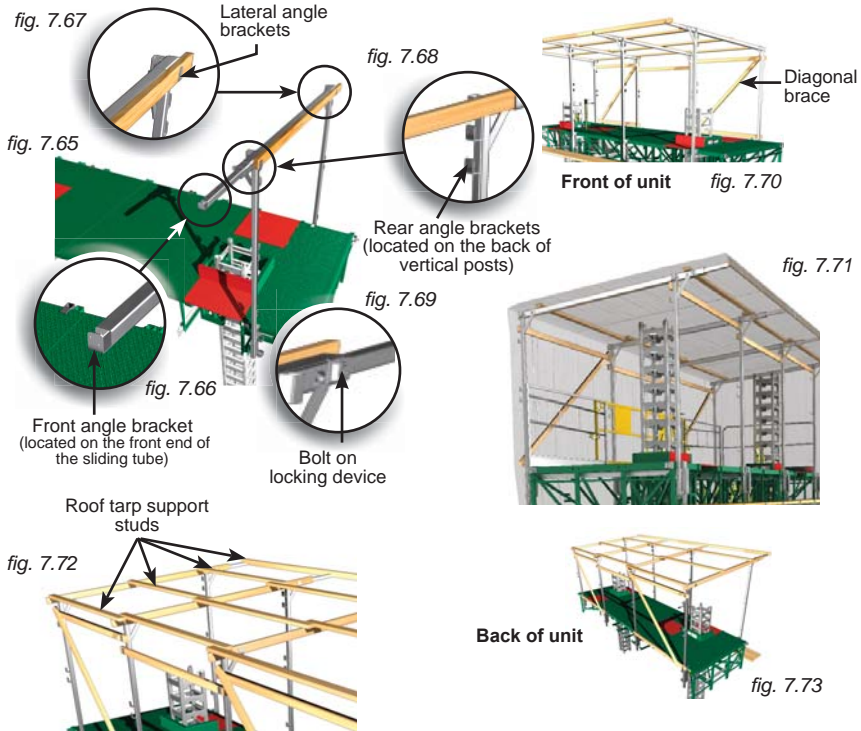

Installation of bracing

- 1- To install **front** bracing, slide 2" x 4" (5 cm x 10 cm) studs through the rear angle brackets located on the front vertical posts. Secure the studs in place using 1 1/2" (3,8 cm) nails or screws.
- 2- To install **rear** bracing, slide 2" x 4" (5 cm x 10 cm) studs through the top and bottom angle brackets located on the back of the rear vertical posts. Secure the studs in place using 1 1/2" (3,8 cm) nails or screws.
- 3- It is **mandatory** to install a diagonal brace every two bays. A bay could be left opened if there is diagonal bracing on both sides of the opening (fig. 7.70).

Installation of the roof tarp

- 1- Install 2" x 4" (5 cm x 10 cm) studs in the angle brackets located at the front end of the sliding tubes, parallel to the face of the work. Secure the studs to the angle brackets with nails or screws.
- 2- Install 2" x 4" (5 cm x 10 cm) support studs at intervals on top of the roof section (fig. 7.72). Make sure that no stud is installed over the locking devices and that the sliding tubes can be retracted if necessary. Secure the studs with nails or screws to the planks attached to the roof structure.
- 3- Install a tarp over the roof structure, using the studs to hold it in place.

Weather Protection

Installation of the lower level structure

- 1- With the motorized unit at 10' (3 m) above base level, insert a vertical post into the pockets located on the **front** bottom support bracket **under** the platform (fig. 7.74 and fig. 7.75, p. 107). The diagonal brace on the vertical post must be turned **away** from the face of the work.
- 2- Slide a taper pin through the **highest** adjustment hole in the vertical post and secure it in place with a hitch pin clip.

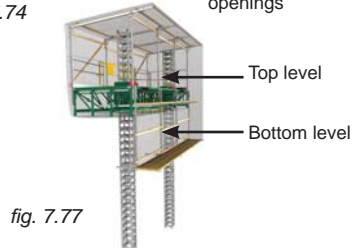
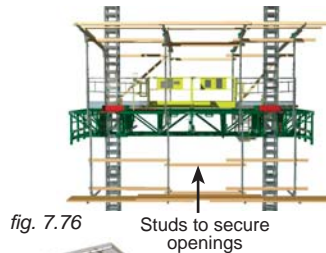
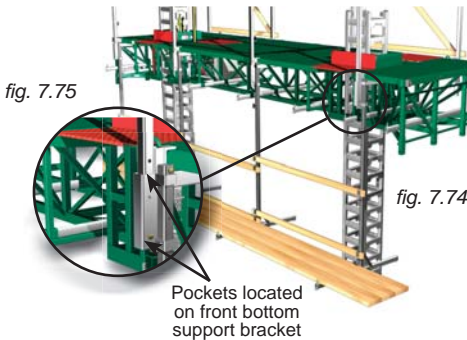

- 3- Tighten the bolts on the pockets of the bottom support bracket.
- 4- Insert a 5' (1,5 m) outrigger in the pocket at the bottom of the vertical post, leaving not more than 3' (0,9 m) protruding from the pocket toward the face of the work. Tighten the pocket bolt only slightly.
- 5- Install as many vertical posts and outriggers as is required by the setup.
- 6- Install planking and push in the outriggers until the plank stop pin is snug against the planks. Tighten all the pocket bolts appropriately to secure the outriggers in place.
- 7- Slide 2" x 4" (5 cm x 10 cm) studs in the middle and bottom angle brackets on the vertical posts to secure the hazardous opening at the back of the lower level structure (fig. 7.76). Secure the studs in place with nails or screws.

Installation of the bottom tarp

- 1- Install 2" x 4" (5 cm x 10 cm) studs in the angle brackets located on the bottom support tubes. Secure the studs to the angle brackets with nails or screws.
- 2- Install a tarp underneath the platform, using the studs to hold it in place.



WARNING

It is important to consider that the platform cannot be brought down completely to base level when weather protection is installed under the structure.

Monorail (optional)

Using the same support structure as the weather protection system, the M2 Series monorail system allows loads of up to 1000 lb (454 kg) to be moved safely along the installation. The M2 Series monorail system can be used on setups with a maximum planking configuration of three planks wide.

It is recommended to refer to and comply with the monorail capacities tables on p. 109 before using a monorail installation. The weight of the monorail structure must also be deducted from the load capacities of the setup. Refer to the *Load Capacities* section on p. 80 to avoid overloading the platform.

Safety guidelines

- 1- The use of a monorail is not allowed on a freestanding installation. For more information about tie levels for an installation with a monorail, refer to the *Mast Tie Schedule* on p. 70 of the *Masts and Mast Ties* section.
- 2- Before installing a monorail, it is important to refer to the general installation guidelines on p. 18 to select the appropriate method of installation for the configuration.

Installation of the support structure

- 1- Follow steps 1 through 3 of the installation procedure for the bottom support structure on p. 104 for each bottom support tube required by the setup. The distance between two bottom supports must not exceed 8' (2,4 m), as shown in fig. 7.78.
- 2- Follow steps 1 through 5 of the installation procedure for the top support structure on p. 104 for each vertical post installation (front and back) required by the setup.
- 3- Remove the locking device and the sliding tube from a 10' (3 m) outrigger and slide the outrigger into the pockets of the front and back vertical posts. Secure the outrigger in place by tightening the pocket bolts.
- 4- Repeat step 3 for each 10' (3 m) outrigger required by the setup.

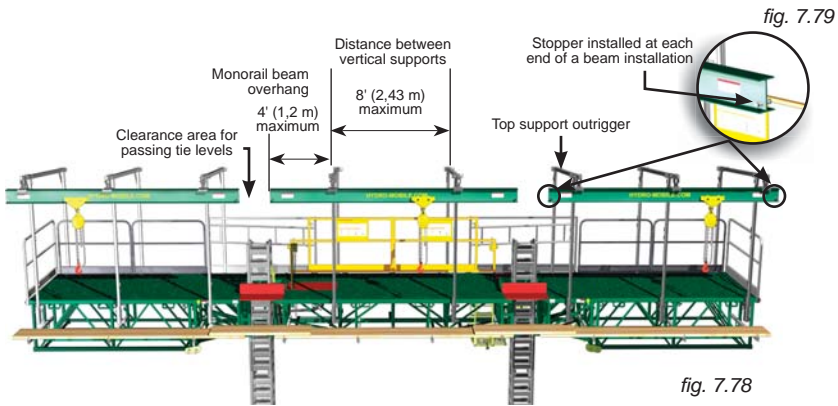

Installation of the monorail beam attachments

- 1- Slide a monorail beam attachment assembly on a top support outrigger (fig. 7.78) of the monorail structure. In a **single unit installation**, use the **upper or lower tubes** (fig. 7.83) of the monorail attachment – using the same position throughout the installation. In a **multiple units installation**, use the **lower tubes** over the **unit** and **cantilever bridges** and the **upper tubes** over the **bearing bridge** (fig. 7.80).
- 2- Secure the monorail beam attachment in place by tightening the pocket bolt.
- 3- Loosen all four bolts on a monorail bracket (fig. 7.78) to slacken the attachment plates on the bottom.

**Monorail
(optional)**

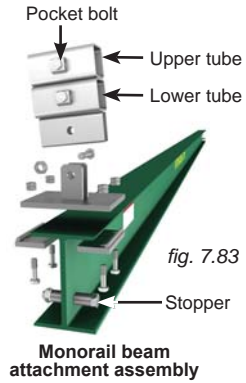
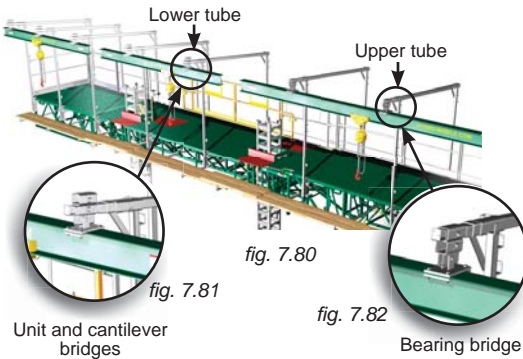

Installation of the monorail beams

- 4- Repeat steps 1 through 3 for each of the monorail beam attachments required by the setup.
- 5- Once all the monorail beam attachments are secure, slide the top of monorail beams between two attachment plates at the bottom of the beam attachment assemblies.
- 6- Secure the monorail beams in place by tightening the four bolts on each of the attachment plates (fig. 7.84). If required, join beams together using monorail beam junction plates. Clearance areas can be left open to facilitate the passing of tie levels, as shown on fig. 7.78, p. 108. Beams may be required to be cut to size.
- 7- Make sure that no monorail beam overhangs by more than 4' (1,2 m), as shown in fig. 7.78, p. 108.
- 8- Slide a trolley on the monorail beam. Install as many trolleys as is required and allowed, making sure to install a stopper at each end of every beam installation.

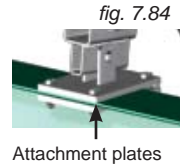

Monorail capacities single installation	
Capacity (lb)	1000
Capacity (kg)	454

fig. 7.85

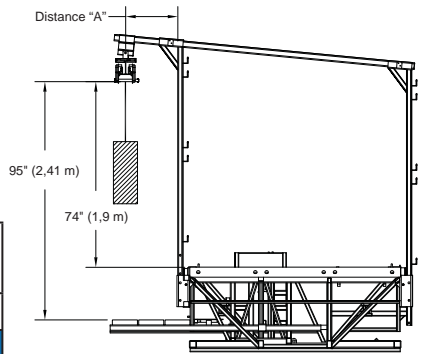

fig. 7.86

Distance "A"	Monorail capacities - single installation as per distance from face of work	
	20" (50,8 cm)	30" (76,2 cm)
Capacity (lb)	1000	700
Capacity (kg)	454	318

fig. 7.87

Flush Bearing Bridge Adapter (optional)

The optional flush bearing bridge adapter is used in a multiple units M2 Series installation to bring the bearing bridge structure at an even level with the motorized unit(s) and achieve a flat deck platform. The flush bearing bridge adapter **cannot be used** to achieve an **offset, angled or corner** (inside or outside) bearing bridge installation.

It is important to consider that the weight of the adapter (350 lb or 159 kg) must be deducted from the load capacities of the motorized unit.

The following installation steps must be carried out as part of a selected method of installation appropriate for the configuration. For more information about setups and configurations, refer to p. 18 of the *Motorized Unit* section.

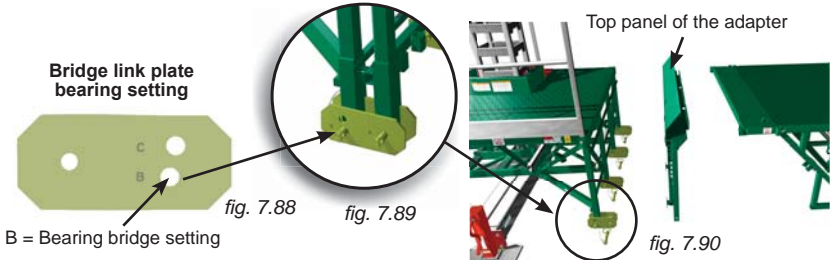

Installation of the flush bearing bridge adapter

- 1- Lift the top panel on the flush bearing bridge adapter. Align the adapter with the motorized unit.
- 2- Bolt the top part of the of the adapter to the top of the first motorized unit using four 1" x 2" long (GR5) bolt assemblies through the four **outer assembly sockets** in the front and the back of the motorized unit. **Do not tighten the bolt and nut assemblies yet.**
- 3- Attach the bottom part of the adapter to the bottom of the motorized unit using bridge link plates and pins sets (4) at the bearing bridge setting (fig. 7.88 and fig. 7.89).
- 4- **Tighten the bolt assemblies** (4) at the top of the adapter to 100 lb-ft (136 N-m). **Make sure to leave the top panel open.**
- 5- Repeat steps 1 through 5 to install an adapter on the second motorized unit.

Positioning the first motorized unit

- 6- Prepare the first motorized unit and the area where the setup will be installed as described in the general guidelines on p. 18 (steps 1 through 15). Make sure all base outriggers are properly configured according to the installation.

Positioning the second motorized unit

- 7- Determine the position of the second motorized unit. It is **essential** to make sure that the **appropriate distance** between the two motorized units is **calculated precisely** by measuring the length of the bearing bridge structure **without any allocations for overlap**.
- 8- Prepare the second motorized unit and the area where it will be installed as described in the general guidelines on p. 18 (steps 1 through 15). Make sure all base outriggers are properly configured according to the installation.

Installation of the bearing bridge structure

- 9- Assemble the bearing bridge structure as required and allowed. Refer to steps 1 through 6 of the installation instructions for a bearing bridge structure, on p. 46 of the *Bridges* section.



WARNING

The flush bearing bridge adapter **cannot be used** to achieve an **offset, angled or corner** (inside or outside) bearing bridge installation.

Flush Bearing Bridge Adapter (optional)

Installation of the bearing bridge structure (cont'd)

- 10- Using a rough terrain forklift or a crane, lift the bearing bridge assembly from the ground and lower it carefully between the two motorized units, making sure that the bearing bridge adapter is properly hooked on the flush bearing bridge adapter at each end.
- 11- Close the top panel on each flush bearing bridge adapter and follow steps 12 to 14 of the installation instructions on p. 46 of the *Bridges* section to complete the installation of the bearing bridge.
- 12- Install the safety chains as described in step 10 of the installation instructions for a bearing bridge structure, on p. 47 of the *Bridges* section.
- 13- Proceed with the installation steps as described in the method of installation appropriate for the configuration. For more information about methods of installation, refer to p. 18 of the *Motorized Unit* section.

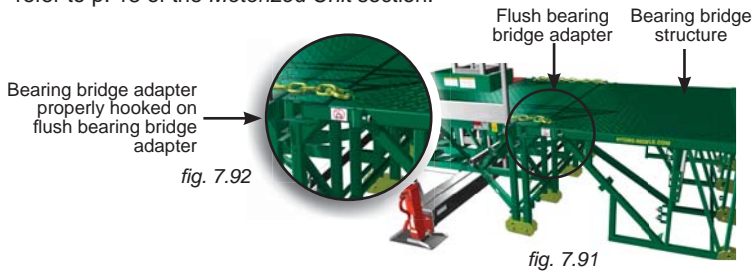

WARNING

It is **essential** to make sure that the **appropriate distance** between the two motorized units is **calculated precisely** by measuring the length of the bearing bridge structure **without any allocations for overlap where a flush bearing bridge adapter will be installed.**

Securing the Access Walkway

The installation and use of some M2 Series applications, such as the sidewalk canopy and the mast base plates, will require that the access walkway be folded and locked in place. It is essential to proceed with extreme care to avoid any crushing hazard.

- 1- With the motorized unit at base level, slide an outrigger through the walkway over a bottom truss of the structure (see "1" in fig. 7.93).
- 2- Using a U-bolt, secure the outrigger to the truss (see fig. 7.94 and "2" in fig. 7.93).
- 3- Use the chain to secure the access panel on the motorized unit to prevent use.

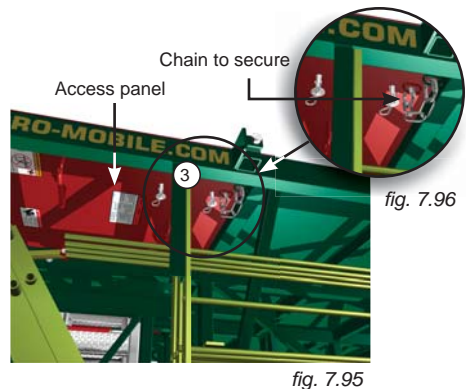

Adapter Bases for Sidewalk Canopy Installation (optional)

Optional adapter bases for sidewalk canopy installation are used to install an M2 Series motorized unit at 10' (3 m) above the bearing surface, as part of a sidewalk canopy installation. The adapter bases for sidewalk canopy installation can be used in any single or multiple units M2 Series configuration **with mast ties**. An M2 Series configuration using adapter bases for a sidewalk canopy installation cannot be raised higher than 200' (61 m) above base level.

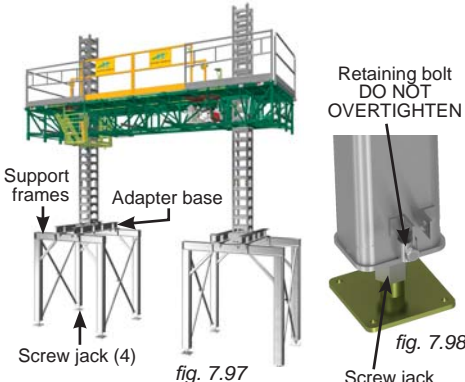

fig. 7.97

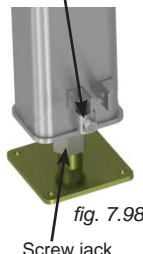

fig. 7.98

Minimum Bearing Surface Capacities Installation with a Sidewalk Canopy		
Height		Load under each screw jack
(ft)	(m)	Reaction
50	15,2	8298 lb
		3764 kg
75	22,9	8755 lb
		3971 kg
100	30,5	9211 lb
		4178 kg
150	45,7	10 123 lb
		4592 kg
200	61,0	11 036 lb
		5006 kg

fig. 7.99 Load reactions in the table above include a dynamic factor

Installation of the adapter bases

- 1- Before installing the adapter bases, determine where the cribbing and the jacks will rest. When required, appropriate cribbing must be placed under each screw jack on the legs of each support frame to distribute the load. Typically, for an installation without any planking, the support frames for the adapter bases will be installed at 8" (20 cm) from the face of the wall. Refer to p. 13 and p. 14 for the appropriate distance of installation between the two adapter bases.
- 2- The bearing surface under the adapter bases should be level, clear of debris and have a bearing capacity sufficient to support the load under each screw jack. It is important to make sure that the bearing surface is stable and has not been subject to any type of erosion or deterioration caused by weather conditions (snow, rain, etc.).

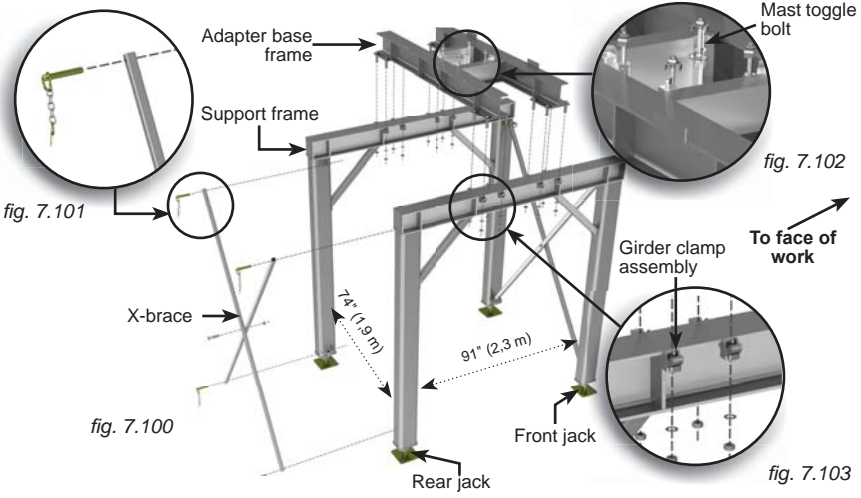

Adapter Bases for Sidewalk Canopy Installation (optional)

Installation of the adapter bases (cont'd)

- 3- Mark the position of jacks. The distance between the front and rear jacks is 91" (2,3 m), while the distance between the left and right jacks is 74" (1,9 m) (fig. 7.99, p. 112).
- 4- Using the supplied X-braces, assemble the two frames of the first base support structure together. Verify the squareness of the assembly and make corrections, if necessary.
- 5- Loosen the retaining bolt on each leg of the frames (fig. 7.98, p. 112) to release the screw jacks.
- 6- Repeat steps 3 to 5 for the second support structure.
- 7- Using a rough terrain forklift or a crane, lift and position the first adapter base frame on top of one support assembly. Refer to the table in fig. 7.104 to determine the distance between the mounting flange on the adapter base and the front edge of the support assembly. The adapter base frame will be moved back by 10" to 12" (25 cm to 30 cm) from the front edge of the support assembly for each plank required by the configuration (as shown in fig. 7.104). If necessary, install the support assembly further back from the face of the wall for larger planking configurations (see step 1 and fig. 7.104). Use the *Outrigger Selection* table on p. 95 as a guide for planking configurations.
- 8- Secure the adapter base to the support assembly by tightening each girder clamp assembly (fig. 7.102, p. 112) to a torque of 108 lb-ft (147 N-m).
- 9- Verify the level of the adapter base and the support assembly. Adjust the level using the screw jacks on the support assembly or by adding cribbing.
- 10- Repeat steps 7 through 9 for the second adapter base.

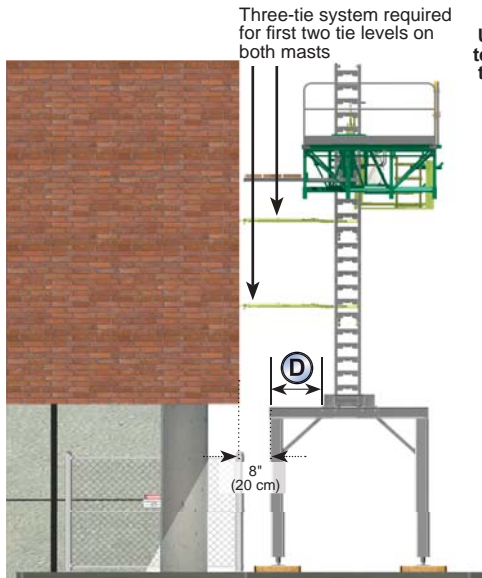

fig. 7.104 Unit on adapter base for sidewalk canopy installation with three-plank configuration

Unit must be held up by a crane or rough terrain forklift during installation until first two tie levels are installed on both masts



fig. 7.105

Number of planks	Distance "D"
0	14" (36 cm)
1	24" (61 cm)
2	34" (86 cm)
3	44" (112 cm)

Distance "D" in the above table is based on a 8" (20,3 cm) clearance between the support structure and the face of work, with a 10" (25 cm) wide planking configuration.



WARNING

Once the unit is installed on the adapter base, it is **mandatory** to install the **first two tie levels on both masts** before proceeding with the installation.

Adapter Bases for Sidewalk Canopy Installation (optional)

Installation of the motorized unit

- 11- On each mast on the motorized unit, make sure that there are two mast sections installed on each mast (fig. 7.102) in addition to the mast sections welded on the base.
- 12- Before lifting and moving the motorized unit, make sure all workers have stepped down, that all tools, equipment and loads have been removed from the platform and that the mast locking bars are in place. Fold and lock the access walkway, as described in the instructions on p. 111.
- 13- Raise the motorized unit up to the second mast sections until it is above the mast toggle bolts.
- 14- Using a rough terrain forklift or a crane, support the motorized unit. Refer to p. 37 of the *Motorized Unit* section for instructions on the lifting of a motorized unit. Loosen and flip down the mast toggle bolts joining the lowest mast sections to the mast sections welded on the base.
- 15- Lift and carefully lower the motorized unit on top of the adapter bases.
- 16- **Continue to hold the motorized unit** and secure it to the adapter bases with the mast toggle bolts located on the adapter bases. Tighten all bolts to 120 lb-ft (163 N-m) of torque, using a cross-pattern sequence when tightening. Remove the mast locking bars.
- 17- **Still holding the motorized unit**, install **two tie levels** to tie the masts to the face of the work. It is important to use a **three-tie** system for the **first two tie levels**. Refer to p. 70 of the *Masts and Mast Ties* section for instructions on how and when to install mast ties.
- 18- Once the first two tie levels are installed, make sure that hooks are properly engaged on a mast rung on both masts and release the unit. Proceed with the installation steps as described in the method of installation appropriate for the configuration. For more information about methods of installation, refer to p. 18 of the *Motorized Unit* section.

Dismantling guidelines

- 1- Make sure all the equipment necessary for a safe dismantlement of the installation is on hand (slings, chains, crane or rough terrain forklift, etc.). **Make sure the regular motorized unit base is also on hand.**
- 2- Follow the dismantling instructions appropriate for the configuration **leaving the last two tie levels in place**. For dismantling instructions, refer to the *Motorized Unit* section, starting on p. 32.
- 3- Before lifting and moving the motorized unit, make sure all workers have stepped down, that all tools, equipment and loads have been removed from the platform and that the mast locking bars are in place.
- 4- Using a rough terrain forklift or a crane, support the motorized unit. Refer to p. 37 of the *Motorized Unit* section for instructions on the lifting of a motorized unit. Remove the last two tie levels on each mast. Make sure that the motorized unit remains on the second mast sections, above the mast toggle bolts joining them to the first mast sections installed.
- 5- **Still holding the motorized unit**, loosen all toggle bolts and clamps holding the unit to the adapter bases.
- 6- To ensure proper stability, **make sure that the regular base is level**. Carefully lift the motorized unit off the sidewalk canopy frames and lower it on top of the regular base.
- 7- **Continue to hold the unit** and secure it to the base by tightening all bolts to 120 lb-ft (163 N-m) of torque, using a cross-pattern sequence when tightening.
- 8- Once the base is secured, make sure that hooks are properly engaged on a mast rung on both masts and release the motorized unit.
- 9- Remove the adapter bases from the support assemblies.

Adapter Bases for Sidewalk Canopy Installation (optional)

Dismantling guidelines (cont'd)

- 10- Remove the mast locking bars and lower the motorized unit to base level.
- 11- Unlock the access walkway and remove the additional mast sections installed on each mast of the unit.
- 12- Remove the X-braces and disassemble the support assemblies.
- 13- If the unit is to be stored for any significant length of time, refer to p. 118 of the *Transport, Storage and Maintenance* section for instructions on how to properly store an M2 Series motorized unit.

Mast Base Plates (optional)

Optional mast base plates are used to install an M2 Series motorized unit in areas where space is restricted around the base. The mast base plates can be used in any single or multiple units M2 Series configuration **with mast ties**.

Installation

- 1- Before installing the mast base plates, determine where the cribbing will rest. The bearing surface under the cribbing should be level, clear of debris and have the proper bearing capacity. Refer to the *Minimum Bearing Surface Capacities for an Installation with Mast Base Plates* table, fig. 7.108 for guidance. Should the actual bearing capacity be inferior to the values in the table, please seek instructions and recommendations from Hydro Mobile.

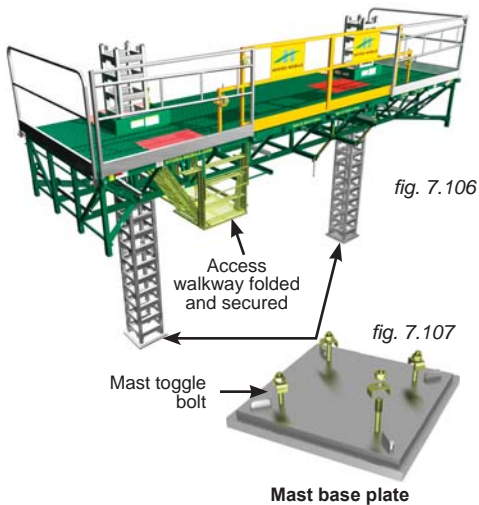

fig. 7.108

Minimum Bearing Surface Capacities Installation with a Mast Base Plate		
Height		Load under each mast
(ft)	(m)	Reaction
50	15,2	22 735 lb
		10 312 kg
75	22,9	23 985 lb
		10 879 kg
100	30,5	25 235 lb
		11 446 kg
150	45,7	27 735 lb
		12 580 kg
200	61,0	30 235 lb
		13 714 kg
250	76,2	32 735 lb
		14 848 kg

Load reactions in the table above include a dynamic factor



WARNING

On an installation where the unit is not on its regular base and is on adapter bases or mast base plates, it is **mandatory to use a three-tie system for the first two tie levels.**

Mast Base Plates (optional)

Installation (cont'd)

- 2- On each mast on the motorized unit, make sure that there are two mast sections installed in addition to the mast sections welded on the base.
- 3- Before lifting and moving the motorized unit, make sure all workers have stepped down, that all tools, equipment and loads have been removed from the platform and that the mast locking bars are in place. Fold and lock the access walkway, as described in the instructions on p. 111.
- 4- Raise the motorized unit up to the second mast sections until it is above the mast toggle bolts joining them to the first mast sections installed.
- 5- Using a rough terrain forklift or a crane, support the motorized unit. Refer to p. 37 of the *Motorized Unit* section for instructions on the lifting of a motorized unit. Loosen and flip down the mast toggle bolts joining the lowest mast sections to the ones welded on the base.
- 6- Lift and carefully lower the motorized unit on top of the mast base plates.
- 7- **Continue to hold the motorized unit** and secure it to the mast base plates with the mast toggle bolts located on the mast base plates. Tighten all bolts to 120 lb-ft (163 N-m) of torque, using a cross-pattern sequence when tightening. Remove the mast locking bars.
- 8- **Still holding the motorized unit**, install **two tie levels** to tie the masts to the face of the work. It is important to use a **three-tie** system for the **first two tie levels**. Refer to p. 70 of the *Masts and Mast Ties* section for instructions on how and when to install mast ties.
- 9- Once the **first two tie levels are installed**, make sure that hooks are properly engaged on a mast rung on both masts and release the unit. Proceed with the installation steps as described in the method of installation appropriate for the configuration. For more information about methods of installation, refer to p. 18 of the *Motorized Unit* section.

Dismantling guidelines

- 1- Make sure all the equipment necessary for a safe dismantlement of the installation is on hand (slings, chains, crane or rough terrain forklift, etc.). **Make sure the regular motorized unit base is also on hand.**
- 2- Follow the dismantling instructions appropriate for the configuration **leaving the last two tie levels in place**. For dismantling instructions, refer to the *Motorized Unit* section, starting on p. 32.
- 3- Before lifting and moving the motorized unit, make sure all workers have stepped down, that all tools, equipment and loads have been removed from the platform and that the mast locking bars are in place.
- 4- Using a rough terrain forklift or a crane, support the motorized unit. Refer to p. 37 of the *Motorized Unit* section for instructions on the lifting of a motorized unit. Remove the last two tie levels.
- 5- Loosen the toggle bolts holding the unit to the mast base plates.
- 6- To ensure proper stability, **make sure that the regular base is level**. Carefully lift the motorized unit off the mast base plates and lower it on top of the regular base.
- 7- **Continue to hold the unit** and secure it to the base by tightening all bolts to 120 lb-ft (163 N-m) of torque, using a cross-pattern sequence when tightening.
- 8- Once the base is secured, make sure that hooks are properly engaged on a mast rung on both masts and release the motorized unit.
- 9- Remove the mast locking bars and lower the motorized unit to base level.
- 10- Unlock the access walkway and remove the additional mast sections installed on each mast of the unit.

Mast Base Plates (optional)

Dismantling guidelines (cont'd)

- 11- If the unit is to be stored for any significant length of time, refer to p. 118 of the *Transport, Storage and Maintenance* section for instructions on how to properly store an M2 Series motorized unit.

Multiple Mast Handler (optional)

The use of the multiple mast handler will allow the qualified erector/dismantler to install pre-assembled lengths of mast (also referred to as "sticks") and reduce the time required to achieve the installation of the setup.

Installation

- 1- Pre-assemble a length of mast sections on the ground. Mast sections must be laid down horizontally on the ground. For instructions on the assembly of mast sections, refer to p. 69 of the *Masts and Mast Ties* section. Tighten all bolts to 120 lb-ft (163 N-m). The length of pre-assembled mast allowed will be equal to the authorized height in feet (meters) between two tie levels for the configuration, according to the selected method of installation and the mast tie schedule specific to that method of installation. For more information about methods of installation, refer to p. 18 of the *Motorized Unit* section. Refer also to the *Mast Tie Schedule* on p. 70 for information about distances between tie levels.

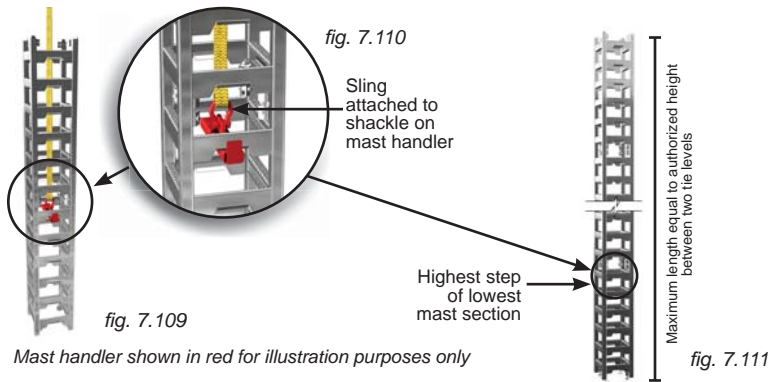

- 2- Install the mast handler on the highest step of the lowest mast section of the pre-assembled length of mast (fig. 7.109). It is important to consider the weight of the pre-assembled length of mast that must be lifted and to make sure to select a sling, chain or cable that can lift that weight. For example, a pre-assembled 30' (9,1 m) length of mast sections will weigh 1410 lb (640 kg).
- 3- Insert the sling (or chain or cable) through the pre-assembled length of mast and attach the hook to the shackle on the mast handler.
- 4- Using a crane (or a forklift), carefully lift and lower the pre-assembled length of mast on top of the last mast section installed.
- 5- Still holding the length of mast, attach the bottom mast section to the top of the mast section already installed. For instructions on the assembly of mast sections, refer to p. 69 of the *Masts and Mast Ties* section. Tighten all bolts to 120 lb-ft (163 N-m).
- 6- Remove the shackle from the mast handler to release the hook and sling.
- 7- Remove the mast handler from the mast section.
- 8- Raise the motorized unit on the newly added length of mast and install the next tie level.
- 9- Repeat steps 2 to 8 for each pre-assembled length of mast to install, as required and allowed.

Transport and Storage

Preparation of the motorized unit for transport

- 1- Dismantle the motorized unit setup following the appropriate guidelines. For any standard configuration using a motorized unit with its regular base, follow the dismantling guidelines starting on p. 32 of the *Motorized Unit* section. For a setup equipped with adapter bases for a sidewalk canopy installation, refer to p. 114 for the appropriate dismantling instructions. Refer to the dismantling guidelines on p. 116 for a setup using mast base plates.
- 2- Once the setup has been dismantled and the unit is at base level, turn off the engine. The choke handle must not be used to shut down the engine.

- 3- Open the engine access panel and move the engine gasoline valve lever to the OFF position.

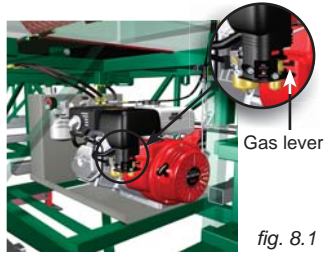

fig. 8.1

- 4- Store the control post.

- 5- Remove the cylinder and secondary hooks.

- 6- Install the transport hook and store the cylinder and secondary hooks in their storage location.

- 7- Retrieve the mast locking bar from its storage location and insert it into the mast. Refer to p. 62 of the *Power Pack and Operating Components* for instructions on the storage of locking bars.

- 8- Repeat steps 5 through 7 on the other mast.

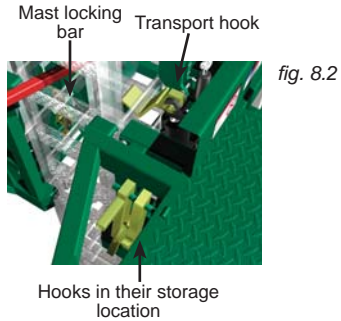

fig. 8.2

- 9- Remove the plank-end guardrails and store them in their storage location.

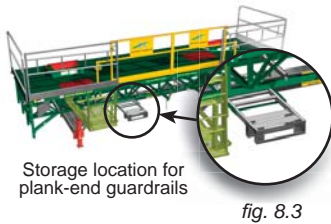

fig. 8.3



fig. 8.4

Transport and Storage

Preparation of the motorized unit for transport

- 10- Remove the end guardrails with the end guardrail pockets and store them in their storage location.

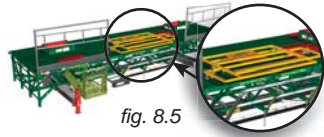

fig. 8.5
Temporarily store sliding doors on the deck of the unit

- 11- Remove the sliding doors and temporarily store them on the deck of the unit.



fig. 8.6

- 12- Remove the door support guardrails and store them in their storage location.

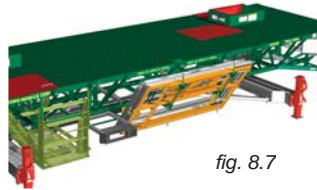

fig. 8.7

- 13- Store the sliding doors with the rest of the guardrails.



fig. 8.8

- 14- Once all guardrails are stored and secured, lower the jacks completely (fig. 8.8).

- 15- Refer to p. 37 of the *Motorized Unit* section for more information on the lifting and transport of a motorized unit.

Storage of the motorized unit

- 1- Inspect the structure of the motorized unit for any sign of damage or distortion. Clean the motorized unit thoroughly to limit the effects of any corrosive agent.
- 2- Prepare the motorized unit as described in the preparation steps on p. 118. If the motorized unit is to be stored for any significant length of time, disconnect the battery.
- 3- Before storing the motorized unit, make sure to place sufficient cribbing under the base to prevent damages to the bottom of the structure.
- 4- Choose an appropriate storage location.
Avoid storing the motorized unit in a location with direct exposure to aggressive or corrosive materials in the surroundings.

Storage of a bridge

- 1- Inspect the structure of the bridge, including the inside of the open-end tubes, for any sign of damage or distortion. Clean the bridge and its components thoroughly to limit the effects of any corrosive agent.



WARNING

Before transporting or storing a motorized unit, make sure that the gasoline valve lever has been turned OFF. Disconnect the battery if the motorized unit is to be stored for any significant length of time.

Transport and Storage

Storage of a bridge

- 2- Bridges must not be stored directly on the ground. Make sure to place sufficient cribbing under the bottom chords to prevent damages to the bottom of the structure.
- 3- Avoid storing the bridge in a location with direct exposure to aggressive or corrosive materials in the surroundings.

Inspections and Maintenance

Proper maintenance and service will warrant safe, economical, and trouble-free operation of an M2 Series motorized unit and its accessories. In order to ensure operational safety and avoid failures, the owner must make sure that all the scheduled inspection and maintenance operations have been effectively and timely carried out according to the inspection and maintenance schedules recommended for M2 Series motorized units and their accessories. Blank copies of the daily inspection checklist must be available on job sites at all times to be filled out when daily and weekly inspection operations are carried out. Maintenance and inspection logs must be kept on record for warranty and safety purposes.

Copies of all maintenance and inspection checklists can be obtained by contacting the distributor/service center or the Hydro Mobile technical support team or downloaded directly from the Hydro Mobile website at www.hydro-mobile.com.

Daily and Weekly Inspections and Maintenance

Each Hydro Mobile motorized unit and its accessories must be submitted to daily (or before every working shift) and weekly inspections and maintenance operations performed by the qualified operator. For more information about a qualified operator, refer to p. 5 of the *Motorized Unit* section.

Daily and weekly inspection operations are only necessary when the motorized unit and its accessories are in use. The owner and/or user is responsible for all inspection and maintenance operations. Before being first used on a job site, an M2 Series motorized unit and its accessories must be inspected effectively and timely, according to the schedules recommended for M2 Series motorized units and their accessories.

Maintenance and inspection logs must be kept on record for warranty and safety purposes. Blank copies of the daily inspection checklist must be available on job sites at all times to be filled out when daily and weekly inspection operations are carried out. The notes and comments form must be used to indicate any discrepancy or any item found to be not acceptable. Any discrepancy must be reported to the owner/user and appropriate corrective action must be taken immediately. Corrective actions must be performed by qualified personnel.

Inspection and maintenance of the cylinder hook

To ensure safe and trouble-free operation of the cylinder hook, it is **mandatory** to inspect it **as per the maintenance schedule**. A worn rubber must be replaced immediately, before operating the motorized unit. A worn and defective rubber will prevent the cylinder hook from working correctly and engage properly on mast rungs.

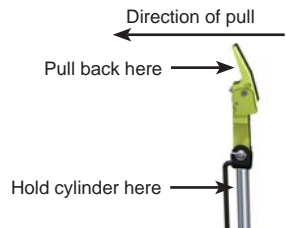

fig. 8.9

- 1- Hold the cylinder firmly (fig. 8.9) and pull the hook all the way back.
- 2- Let go of the hook and verify its position.

Inspections and Maintenance

Daily and Weekly Inspections and Maintenance

Inspection and maintenance of the cylinder hook (cont'd)

- 3- The hook **must not lean** towards or away from the mast, but stand up straight as in "B" in fig. 8.10. If the position of the hook is as in "A" or "C" in fig. 8.10, the rubber must be replaced immediately.

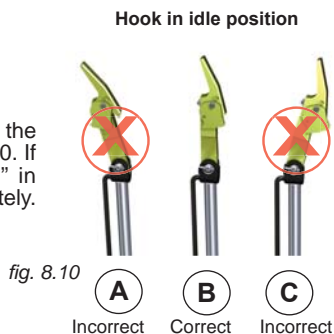

Replacement of the rubber of the cylinder hook

- 1- Remove the lynch pin and slide out the clevis pin (GR8) (fig. 8.11). Lift the hook from the cylinder.
- 2- Remove the defective rubber.
- 3- Cut **slight** beveled edges lengthwise on the replacement rubber (see fig. 8.12) so that it fits snugly against the welding tracks at the bottom of the pocket.
- 4- Insert the replacement rubber in the top part of the cylinder. Slide in the hook and verify that the holes in the hook and the holes in the top part of the cylinder align properly, with no more than 1/16" to 1/8" (1,6 mm to 3,2 mm) of play. **The rubber must be lightly compressed.** Trim the bottom part of the rubber until the holes align correctly.
- 5- Once the rubber fits correctly, replace the hook and secure it in place with the clevis and lynch pins.
- 6- Test the operation of the cylinder hook as described in steps 1 through 3 of the inspection instructions.

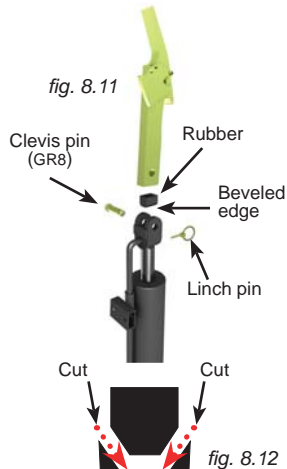

Cut beveled edges on the replacement rubber only deep enough for fitting

Greasing the mast carriage guide rollers

To ensure safe and trouble-free operation, it is **mandatory** to grease each mast carriage roller (32) as part of the **weekly** inspection and maintenance operations.

A proper greasing will extend the life expectancy of the rollers. Rollers shown in red in fig. 8.14 must be greased using only Prolab GS1000 grease.



fig. 8.13

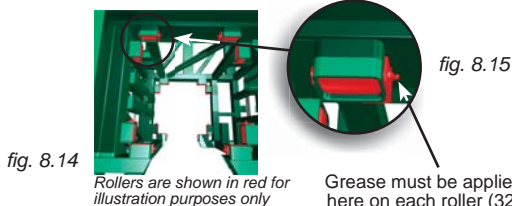

Inspections and Maintenance

Daily and Weekly Inspections and Maintenance

Inspecting and greasing the safety hooks

The safety hooks are an important part of the safety mechanism of the M2 Series mast climber and must be able to move freely at all times and be in appropriate working condition. To ensure the proper operation of safety hooks, they must be inspected and greased as part of the **weekly** inspection and maintenance operations.

- 1- Inspect each safety hook (4) to make sure that there is no sign of engagement. If there are signs of an engagement, each safety hook must be thoroughly inspected by a **qualified technician**. It is mandatory to replace any triggered safety hook and its pivot bolt immediately before resuming operation of the unit. **The replacement of a safety hook must be performed by the qualified technician.** For information about qualified technicians, refer to p. 5 of the *Motorized Unit* section.
- 2- Inspect each safety hook to make sure that there is no indication of excessive grease. If there are signs of excessive grease, a **qualified technician** must take the safety hook apart and clean it properly.
- 3- Apply grease to each safety hook (4) as part of the **weekly** inspection and maintenance operation. Safety hooks must be greased using only Prolab GS1000 grease.



fig. 8.17

Grease must be applied here on each safety hook (4)

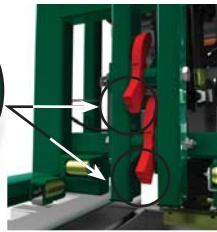

Safety hooks are shown in red for illustration purposes only

fig. 8.16

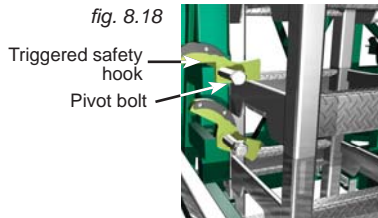

fig. 8.18

Any triggered safety hook and its pivot bolt must be replaced immediately before resuming operation of the unit

Inspections and Maintenance

Frequent Inspections and Maintenance

Frequent inspections must be performed by a qualified technician. For more information about qualified technicians, refer to p. 5 of the *Motorized Unit* section.

Each Hydro Mobile motorized unit must be submitted to a frequent inspection performed every three months by a qualified technician.

Maintenance and inspection logs must be kept on record for warranty and safety purposes. Blank copies of the frequent inspection checklist must be filled out when frequent inspection operations are carried out. The notes and comments form must be used to indicate any discrepancy or any item found to be not acceptable. Any discrepancy must be reported to the owner/user and appropriate corrective action must be taken immediately. Corrective actions must be performed by a qualified technician. For more information about qualified technicians, refer to p. 5 of the *Motorized Unit* section.

All inspection and maintenance steps included in the daily inspection checklist must be performed before the frequent inspection and maintenance steps.

It is recommended to use replacement parts manufactured by or recommended by Hydro Mobile. The use of substitute parts could not only void the warranty covering this motorized unit and its components but cause serious damages that could lead to injury or death. It is recommended to replenish and grease components only with fluids and lubricants recommended by Hydro Mobile.

Annual Inspections and Maintenance

Annual inspections must be performed by a qualified technician. For more information about qualified technicians, refer to p. 5 of the *Motorized Unit* section.

Each Hydro Mobile motorized unit must be submitted to an annual inspection performed by a qualified technician. This annual inspection must be carried out no later than 13 months after the previous annual inspection.

Maintenance and inspection logs must be kept on record for warranty and safety purposes. Blank copies of the annual inspection checklist must be filled out when annual inspection operations are carried out. The notes and comments form must be used to indicate any discrepancy or any item found to be not acceptable. Any discrepancy must be reported to the owner/user and appropriate corrective action must be taken immediately. Corrective actions must be performed by a qualified technician. For more information about qualified technicians, refer to p. 5 of the *Motorized Unit* section.

It is recommended to use replacement parts manufactured by or recommended by Hydro Mobile. The use of substitute parts could not only void the warranty covering this motorized unit and its components but cause serious damages that could lead to injury or death. It is recommended to replenish and grease components only with fluids and lubricants recommended by Hydro Mobile.

Inspections and Maintenance

Copies of inspection and maintenance checklists shown below can be obtained by contacting the distributor/service center or the Hydro Mobile technical support team or downloaded directly from the Hydro Mobile website at www.hydro-mobile.com.

Daily inspection checklist

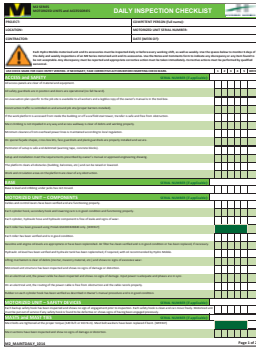

The Daily Inspection Checklist form includes sections for: **General Information** (Project Name, Date, Inspector, etc.), **Visual Inspection** (Oil level, Air filter, etc.), **Operational Inspection** (Start-up, Running, Shut-down), **Performance** (Fuel consumption, etc.), and **Maintenance** (Oil change, etc.). It features a large grid for recording inspection results.

fig. 8.19

Frequent inspection checklist

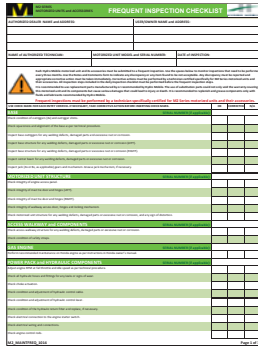

The Frequent Inspection Checklist form includes sections for: **General Information** (Project Name, Date, Inspector, etc.), **Visual Inspection** (Oil level, Air filter, etc.), **Operational Inspection** (Start-up, Running, Shut-down), **Performance** (Fuel consumption, etc.), and **Maintenance** (Oil change, etc.). It features a large grid for recording inspection results.

fig. 8.20

Annual inspection checklist

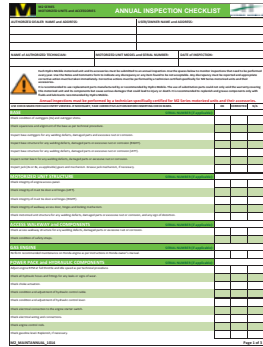

The Annual Inspection Checklist form includes sections for: **General Information** (Project Name, Date, Inspector, etc.), **Visual Inspection** (Oil level, Air filter, etc.), **Operational Inspection** (Start-up, Running, Shut-down), **Performance** (Fuel consumption, etc.), and **Maintenance** (Oil change, etc.). It features a large grid for recording inspection results.

fig. 8.21

Copies of the job survey checklist and the handover checklist shown below can be obtained by contacting the distributor/service center or the Hydro Mobile technical support team or downloaded directly from the Hydro Mobile website at www.hydro-mobile.com.

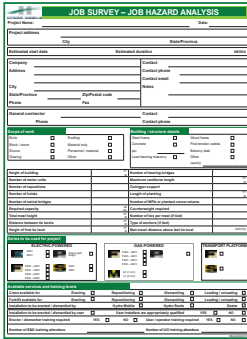

The Job Survey - Job Hazard Analysis form includes sections for: **Project Information** (Project Name, Date, Inspector, etc.), **Job Description** (Job Name, Location, etc.), **Hazard Identification** (List of hazards, Risk Assessment), and **Control Measures** (List of control measures, Implementation). It features a large grid for recording hazard analysis results.

fig. 8.22

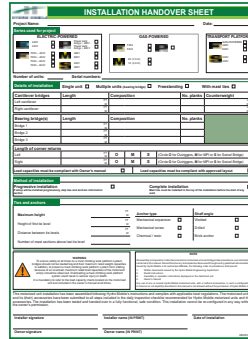

The Installation Handover Sheet form includes sections for: **Project Information** (Project Name, Date, Inspector, etc.), **Equipment Details** (Equipment Name, Model, etc.), **Installation Details** (Installation Date, Location, etc.), and **Handover Details** (Handover Date, Location, etc.). It features a large grid for recording handover details.

fig. 8.23

Maintenance

Hydraulic Diagram

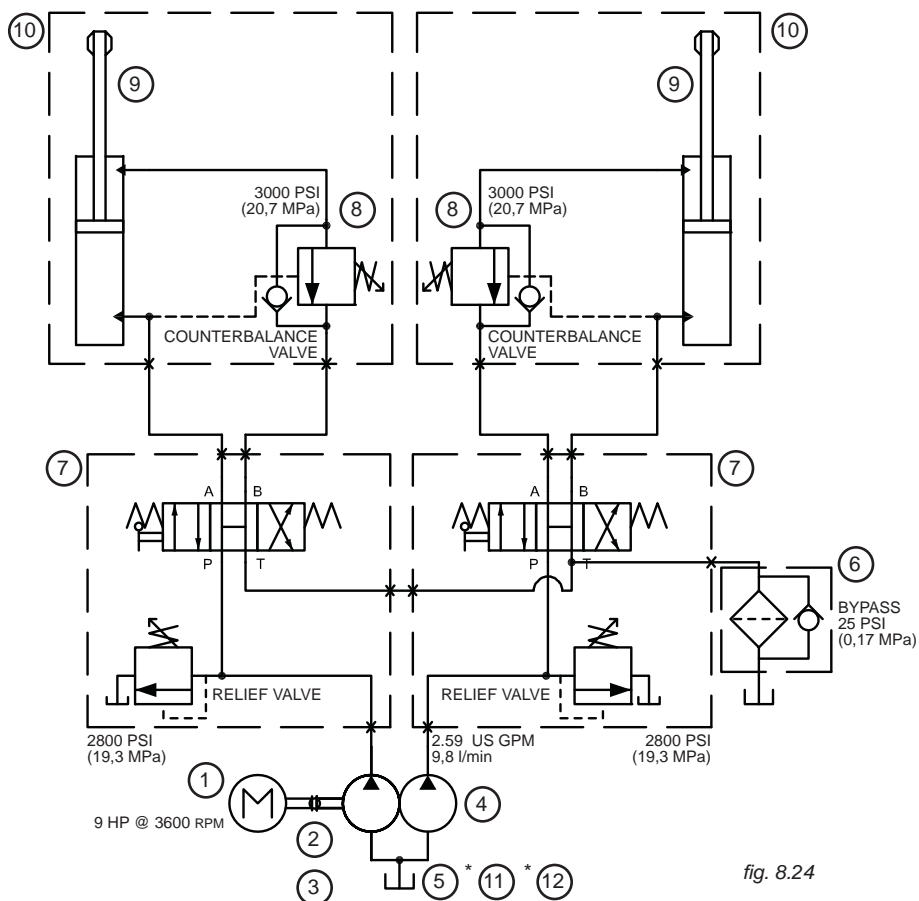

* Part not shown in drawing

ITEM	DESCRIPTION	ITEM	DESCRIPTION
1	ENGINE HONDA 9 HP	7	HYDRAULIC VALVE SD4-ED-SAE (PPWK M2)
2	BELL HOUSING	8	VALVE COUNTERBALANCE SUN 3000 PSI(W/CAP)
3	COUPL KIT L-095 1 1/8-KW 1/4x5/8-KW 5/32	9	CYLINDER 3 1/2x23 1/2x1 1/2
4	PUMP DOUB GEAR (COMMERCIAL)	10	CYLINDER ASS'Y - M2
5	POWERPACK HYDR. FRAME ASS'Y 5.3 US GAL	* 11	CAP. HYD. OIL TANK W / STRAINER (24 HP)
6	ENGINE FILTER OIL W/INDICATOR	* 12	SWITCH GAUGE LEVEL/TEMP (EXT. TANK-LS5)

* Part not shown in fig. 8.2