

Motorized Access Owner's Manual

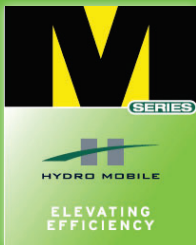

Call us for information:
1-888-484-9376 (US)
(toll free in the United States)
450 589-8100 (Canada)



11053005-0-00000-0

M2_M2MA_v1.02_EN

NOTE

All assembly and operation instructions located in the motorized access car take precedence over information contained in this manual. Should there be any discrepancies discovered throughout any published documentation issued by Hydro Mobile or its authorized affiliates, the following order of precedence shall prevail:

1. Written documents issued by the Hydro Mobile Engineering department
2. Recall instructions
3. Assembly or operation instructions displayed on the motorized unit
4. Owner's manual

Any use of one or several Hydro Mobile motorized units, with or without accessories, in such a configuration or manner as not explicitly described in this manual is prohibited without the prior written permission of Hydro Mobile.

REVISION LIST

Code/Version	Date	Description
11053010-0-00000-0 v 1.0	March 2024	First edition of Owner's manual
11053010-0-00000-0 v 1.01	April 2024	Modification for permission to use M2 Series hoist system under specific conditions
11053010-0-00000-0 v 1.02	May 2024	Changes to method of installation

LEGEND OF ICONS

These icons are used to highlight important information throughout this manual



Danger

Immediate hazard: if not avoided, will result in serious injury, even death



Warning

Hazardous situation: if not avoided, could result in serious injury, even death and equipment damage



Caution

Potentially hazardous situation: if not avoided, may result in minor or moderate injury and equipment damage



Notice

Useful information to avoid equipment damage



Information

Useful information for safe and easy operation



Useful tip

A useful tip to facilitate installation or operation

The information and instructions contained in this manual applies to units bearing the following serial numbers

24M24085 and up

14M20109 and up

GENERAL INFORMATION

Motorized access car serial number _____

Manufacturing date _____



125 de L'Industrie
L'Assomption, Quebec, Canada
J5W 2T9

For orders or information:
1-888-484-9376 (US)
(toll free in the United States)
450 589-8100 (Canada)

11053010-0-00000-0

Performance and Safety Rules



SAFETY comes first. The installation and operation of mast climbing equipment is subject to hazards that can be avoided only by using extreme care and common sense, and by providing the **appropriate training and supervision** to all its users.

It is essential that the **installation and dismantling** of an M2 Series motorized access system be carried out according to the guidelines, instructions and warnings included in the owner's manual and performed by **qualified erectors/dismantlers** under the supervision of a **competent person**. For the definition of a competent person, refer to the M2 Series owner's manual included with the motorized unit.

It is also imperative that the **operation** of an M2 Series motorized access system be carried out according to the guidelines, instructions and warnings included in this owner's manual.

**NOTICE**

It is mandatory to refer to the M2 Series owner's manual included with the motorized unit for complete instructions and for the definitions of qualified persons.

**NOTICE**

It is important to note that the M2 Series motorized access system can only be installed on M2 Series motorized units bearing the following serial numbers: 24M24085 and up; 14M20109 and up. Motorized units bearing a serial number previous to those numbers are not compatible.

General guidelines

- 1- Never modify the mast climbing motorized access system or use substitute parts. This could adversely affect worker safety, unit performance and void the warranty. In addition, this could lead to serious injury or death.
- 2- It is recommended not to smoke inside the car.
- 3- Workers exposed to potential hazards must always wear proper personal protection equipment (PPE) such as a helmet, safety boots, a fall arrest harness, etc., as prescribed by local regulations. In all cases where workers are exposed to fall hazards, fall protection is required.
- 4- To ensure work efficiency, maintain an adequate equipment and parts inventory on the job site. Keep equipment in good condition.
- 5- Contact the distributor/service center or Hydro Mobile for service, repair or technical advice. Refer to equipment type and serial number when calling.
- 6- The qualified erectors/dismantlers in charge of the installation must make sure that the equipment being installed has been duly inspected and meets all applicable safety standards.

When the installation is in use

- 7- The access gate of the motorized access system must be closed when the car is moving or when it is docked under the motorized unit.
- 8- The motorized unit access hatch (red) must be closed when the motorized access car is not docked under the motorized unit.
- 9- In the event of an abnormal occurrence or operation which could compromise safety (for example, malfunction of a motorized access system component, collision with an obstacle, etc.), immobilize the car and inform the competent person. For the definition of a competent person, refer to M2 Series owner's manual included with the motorized unit.
- 10- Do NOT touch any of the moving parts on the motorized access system when it is in use.

Inspection and maintenance of the equipment and accessories

- 11- Inspection and maintenance operations must be carried out efficiently and in a timely manner. Daily inspections and their related operations must be performed by a qualified user/operator every day or before every working shift. Frequent and annual inspections and their related operations must be carried out by a qualified technician. Refer to the M2 Series owner's manual included with the motorized unit for complete instructions on inspection and maintenance of equipment and accessories.

Motorized Access System

Motorized Access System – Overview

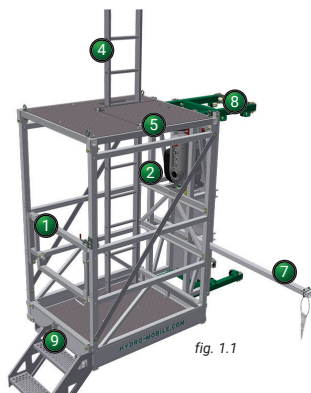

fig. 1.1

Ref	Component
1	Access gate
2	Traction hoist controls
3	Limit switch trigger plate assembly
4	Ladder
5	Roof access hatch
6	Emergency descent device
7	Horizontal power cord support with cable grip
8	Trolley frame
9	Access stairs

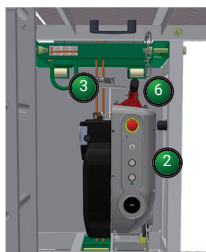

fig. 1.2

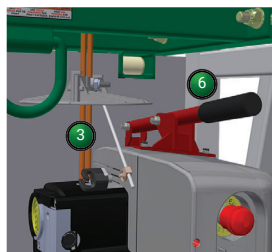

fig. 1.3

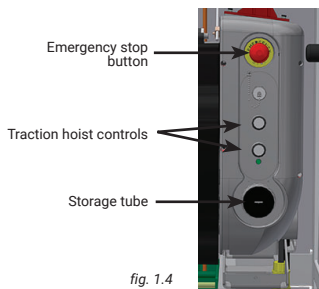

fig. 1.4

**Motorized Access System
Motorized Access System – Overview**

fig. 1.5

List of components included with shipped system	
Qty	Component
1	Motorized access car (including trolley frame)
1	Traction hoist with components
1	Ladder
1	Horizontal power cord support
1	Access stairs
1	Top anchor assembly
1	Mechanical interlock for motorized unit access hatch
1	Limit switch trigger plate
1	M2MA guardrail
1	Two wire ropes with hooks
1	Owner's manual

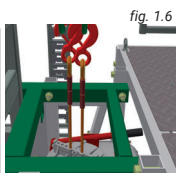

fig. 1.6

Two wire ropes

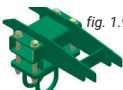

fig. 1.9

Top anchor assembly



Mechanical interlock

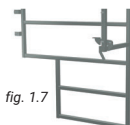

fig. 1.7

M2MA guardrail

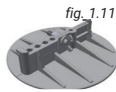

fig. 1.11

Limit switch trigger plate



fig. 1.8

Ladder

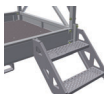

fig. 1.12

Access stairs

Motorized Access System Specifications

fig. 1.13

General Specifications	
Dimensions of the motorized access car assembly	42" x 76" x 76" (W x L x H) (107 cm x 193 cm x 193 cm) (fully assembled)
Travel speed	35'/min (11 m/min)
Capacity	Maximum 3 persons (no material)
Lifting system	Wire rope w/traction hoist (two-wire rope setup) 8.2 mm, TAJURUS 5 x 26WS with 2-ton capacity hooks
Weight of the motorized access car assembly	630 lb (286 kg) (fully assembled)
Weight of the top anchor assembly	30 lb (14 kg)
Weight of M2MA guardrail assembly	32 lb (15 kg)
Safety devices	Emergency descent
	Overspeed safety device
	Top limit switch

fig. 1.14

Power Requirements	
Voltage	280V (+10%/-15%)
Phase	Single phase (1)
Current draw	12A (at working load limit)
Power cord extension	SOOW 10/3 Length of power cord determined by maximum height of setup + 50' (15 m)
Customer power source	Female connector (HBL2323) W/T boot (HBL6031)

Motorized Access System

The motorized access system is used to replace the factory-installed access walkway assembly. Powered by a traction hoist system with two wire ropes, the motorized access system can transport up to three persons (no material) and reach or leave the platform without having to climb up or down the mast.

Installation of the motorized access system



SAFETY comes first. It is essential that the **installation** of an M2 Series motorized access system be carried out by **qualified erectors/dismantlers** under the supervision of a **competent person** in accordance with all applicable local regulations.

For the definition of a competent person or a qualified erector/dismantler, refer to the M2 Series owner's manual included with the motorized unit.

It is mandatory to make sure that the motorized unit installation remains stable and secure throughout the maneuvers to remove the access walkway and install the motorized access system.

General guidelines

- 1- Make sure that all loads have been removed from the motorized unit and that all workers have stepped down before removing the access walkway.
- 2- Make sure all the equipment necessary for a safe installation is on hand (adequate lifting device, slings, chains, etc., as required).
- 3- It is critical to make sure that the two wire ropes have a length appropriate for the height of the installation.



WARNING

It is critical to make sure that the two wire ropes have a length appropriate for the height of the installation.

- 4- It is important to note that the use of the motorized access system is not suitable when certain types of work must be performed with the work platform, such as sandblasting, or if the car and the traction hoist could be exposed to corrosive material, acids, acid fumes, etc. Refer to the traction owner's manual for complete instructions.



NOTICE

The use of the motorized access system may not be suitable when certain types of work must be performed, such as sandblasting, or if the cabin and the traction hoist may be exposed to corrosive material. It is important to refer to the traction owner's manual for complete instructions.

- 5- It is important to note that an M2 Series motorized access system and an M2 Series hoist system installed on the same motorized unit cannot be used simultaneously.
- 6- It is important to note that the motorized access system cannot be installed on a motorized unit where the following is installed:
 - Sidewalk canopy
 - Mast base plate
- 7- When using the motorized access system in cold weather, it is important to refer to the traction owner's manual for instructions.



CAUTION

The motorized access system cannot be installed on a motorized unit where a sidewalk canopy or mast base plate is installed. The M2 Series hoist system must not be used when

Preparation of the motorized unit

It is recommended to perform the following steps in the workshop, before bringing the motorized unit to the job site.

Removal of the access walkway

- 1- Make sure that the access walkway is closed and secure.
- 2- Remove the access walkway and store it properly. For instructions on the removal of the access walkway, refer to p. 10.

Reversal of the base reinforcing brace

The base reinforcing brace must be reversed to avoid interference with the motorized access car.

- 3- Make sure the motorized unit is stable.
- 4- Reverse the base reinforcing brace so that the triangular part is toward the base. For instructions on the reversal of the base reinforcing brace, refer to p. 11.

Motorized Access System

Preparation of the motorized unit

Installation of the M2MA guardrail on the motorized unit

- 5- Install the M2MA guardrail on the motorized unit. For instructions on the installation of the M2MA guardrail, refer to p. 12.



fig. 1.15

M2MA guardrail

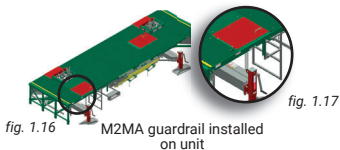

fig. 1.16

M2MA guardrail installed on unit

fig. 1.17

Installation of the M2MA mechanical interlock on the unit access hatch

The mechanical interlock must be installed to prevent the opening of the unit access hatch (red trap door) when the motorized access car is not in position directly below.

- 6- Install the M2MA mechanical interlock assembly, making sure the stopper is positioned properly. For instructions on the installation of the mechanical interlock, refer to p. 12.

Installation of the M2MA mechanical interlock on the unit access hatch

- 7- Make sure that the access stairs, the horizontal power cord support and the access ladder are removed from the car assembly.
- 8- Transport the motorized unit, the car assembly and the other components to the job site. For instructions on the preparation and transport of an M2 Series motorized unit, refer to the M2 Series owner's manual included with the unit.

Installation of the motorized access assembly

Installation of the M2 Series motorized unit

The following installation steps must be performed by qualified erectors only. For the definition of a qualified erector/dismantler, refer to the M2 Series owner's manual included with the unit.

- 9- Make sure a legible copy of the M2 Series motorized unit owner's manual is at hand.
- 10- Install the M2 Series motorized unit following the installation instructions included in the M2 Series owner's manual.
- 11- Make sure to place sufficient cribbing under the left mast as the base outrigger will be pulled out (see following step).
- 12- Make sure to extend the left rear base outrigger to its maximum length (fig. 1.18).

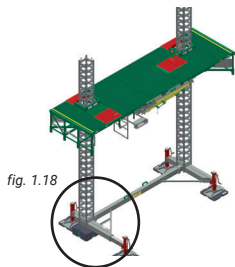
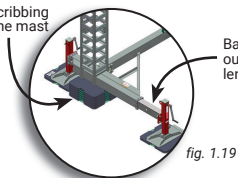

fig. 1.18

Sufficient cribbing under the mast



Base outrigger pulled out to its maximum length

fig. 1.19

Motorized Access System

Installation of the motorized access assembly

Installation of the top anchor assembly

- 13- Install the top anchor assembly. For instructions on the installation of the top anchor assembly, refer to p. 13.
- 14- Hang the two wire ropes to the top anchor assembly.

Preparation of the motorized unit platform

- 15- Install at least three mast sections on each mast. For instructions on the installation of mast sections, refer to the M2 Series owner's manual included with the unit.
- 16- Raise the motorized unit until the two climbing hooks are on the **bottom first** rung of the third full mast section and are both fully retracted. For instructions on how to raise the motorized unit and retract climbing hooks, refer to the M2 Series owner's manual included with the unit.
- 17- The erector must now climb down the mast to base level by the **front of the motorized unit**.

Preparation of the car assembly

- 18- Flip open the front rollers on the trolley of the car assembly. For instructions on the opening of the front rollers, refer to p. 13.
- 19- Install the horizontal power cord support. For instructions on the installation of the horizontal power cord support, refer to p. 14.
- 20- Install the ladder inside the car assembly. For instructions on the installation of the ladder, refer to p. 14.
- 21- Using a forklift or any other appropriate lifting device, lift the car assembly and install the rubber stopper in working position on the bottom of the car assembly (fig. ZZ).



fig. 1.20

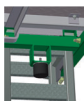

fig. 1.21

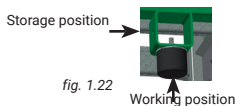

fig. 1.22

Installation of the car assembly and its components

- 22- Position the car **carefully** in line with the mast. It is important to be aware at all times of any possible interference with the motorized unit and the M2MA guardrail (on top), or the leveling jack and the base (at bottom).
- 23- Move the car closer to the mast until the rear rollers are snug against it. Close and secure the four front rollers. Carefully lower the car until the rubber stopper is on the base and release the car from the lifting device.
- 24- Install the access stairs assembly. For instructions on the installation of the access stairs assembly, refer to p. 14.
- 25- Connect the power cord to the traction hoist and secure it carefully along the horizontal support.
- 26- Run the cable through the cable grip assembly and connect it to the power source. Insert the primary suspension rope in the traction hoist. Refer to the traction hoist owner's manual for instructions.
- 27- Insert the secondary wire rope in the traction hoist. Refer to the traction hoist owner's manual for instructions.
- 28- Install the limit switch trigger plate. For instructions on the installation of the limit switch trigger plate, refer to p. 15.

Final verification of the car assembly installation

Once the car is installed, it is important to make a final verification and test the operation of various components.



- 29- Test the operation of the access gate, making sure it closes and opens properly.

Motorized Access System

Installation of the motorized access assembly

Final verification of the car assembly installation (cont'd)

- 30- Make sure the access gate and the roof hatch are closed, then test the operation of the traction hoist by raising and lowering the car. For instructions on how to raise and lower the car, refer to p. 16.
- 31- Test and adjust the operation of the limit switch by raising the car until the limit switch is triggered and the car stops. The car must stop at a height that allows the roof hatch to raise and insert itself into the lock, and for the top of the ladder to release the mechanical interlock on the unit access hatch (red). The distance from the top of the car to the frame of the motorized unit must be at least 14" (35,6 cm). For instructions on the adjustment of the top limit switch trigger plate, refer to p. 15.
- 32- Test the operation of the latch holding the car roof hatch in a vertical position when opened.
- 33- Test the emergency descent procedure as described in the traction hoist owner's manual included with the traction hoist (in the storage tube).
- 34- Verify that the power cord is properly routed and secured to the horizontal support.
- 35- Make sure that the power cord is properly coiled at base level for safe re-coiling when the car returns to base level.
- 36- Secure each of rope (primary and secondary) rope to base level with a 25 lb (11 kg) weight to keep it taut during use. It is important to adjust the position of this weight whenever the height of the motorized unit is modified to avoid unwanted coiling of the rope.
- 37- Secure the tail of the primary suspension rope with a suspension loop and a wire rope clip. For more information, refer to the traction hoist owner's manual.

	CAUTION
Before raising or lowering the car, make sure the access gate and the roof hatch are closed.	
	WARNING
It is mandatory to secure the primary and secondary ropes to base level with weight . The ropes must not be attached to any part of the motorized unit, especially not to the base. It is important to adjust the position of this weight whenever the height of the motorized unit is modified to avoid unwanted coiling of the rope.	

Removal of the access walkway

The installation of the M2 motorized access requires the removal of the access walkway. It is essential to proceed with extreme care to avoid any crushing hazard.

- 1- Make sure that the motorized unit is at base level and that the access walkway is properly supported.
- 2- Use the chain to secure the access hatch (red) on the motorized unit and prevent use.
- 3- Remove the bolt assemblies holding the four vertical supports to the frame of the motorized unit (see "2" in fig. 1.25). Store the bolt assemblies properly for later use.

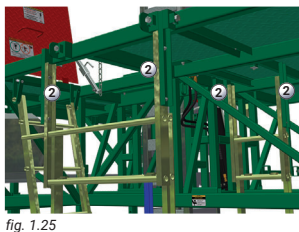
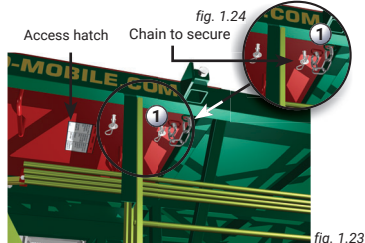

Motorized Access System

Installation of the motorized access assembly

Removal of the access walkway

- 4- Raise the motorized unit by a few inches (centimeters). Remove the bolt assembly closing the left support hook ("3" in fig. 1.26 and fig. 1.27) and store it properly for later use.
- 5- Remove the pin at the bottom of the ladder. Carefully raise the ladder to release the upper part ("4" in fig. 1.27) from the support hooks.
- 6- Remove and store the walkway properly.

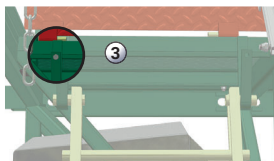

fig. 1.26



fig. 1.27

Reversal of the base reinforcing brace

The base reinforcing brace must be reversed to avoid interference with the motorized access car.

fig. 1.28

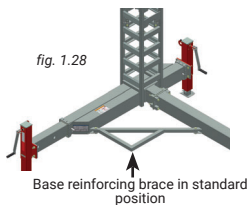
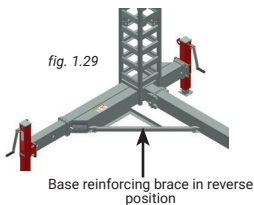

fig. 1.29



- 1- Make sure the motorized unit is stable.
- 2- Remove the bolt assemblies at each end of the reinforcing brace located on the base, on the left side of the motorized unit (fig. 1.32).



fig. 1.31

fig. 1.32



fig. 1.30

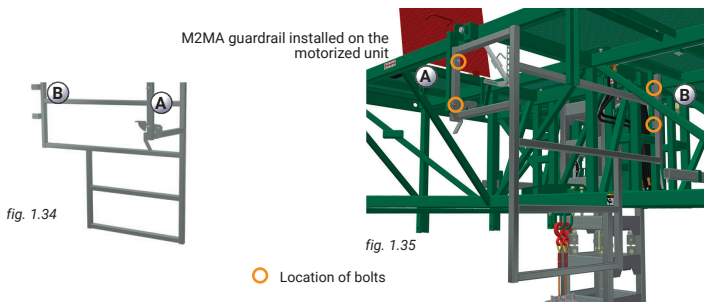

fig. 1.33

- 3- Reverse the base reinforcing brace so that the triangular part is toward the base.
- 4- Secure the brace in place with bolt assemblies. Tighten the bolt assemblies.

Motorized Access System
Installation of the motorized access assembly

Installation of the M2MA guardrail



- 1- Align the M2MA guardrail under the motorized unit (as shown in fig. 1.35).
- 2- Secure the guardrail in place with bolt assemblies shown in locations "A" and "B" in fig. 1.35.

Installation of the mechanical interlock for the unit access hatch

The mechanical interlock must be installed to prevent the opening of the unit access hatch when the car is not docked in position under the motorized unit.

- 1- If necessary, remove the chain securing the unit access hatch.
- 2- Remove the top bolt assembly and the bushing ("1", in fig. 1.37), and the bottom bolt assembly ("2" in fig. 1.37) on the mechanical interlock. Set aside for later use.
- 3- Remove the bolt assembly securing the top part of the hatch latch mechanism to the access panel.
- 4- Insert the bushing and the top bolt assembly ("1" in fig. 1.38) into the top part of the hatch latch mechanism. Tighten the bolt assembly properly.

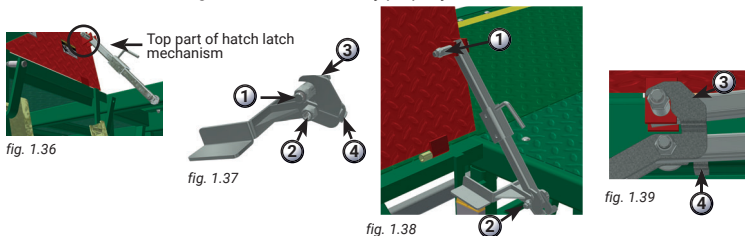

- 5- Remove the nut from the bolt welded to the tube at the bottom of the hatch latch. Insert the mechanical interlock over the bolt. Tighten the nut properly to secure in place.
- 6- Close the hatch and make sure the top part of the interlock ("3" in fig. 1.39) hooks properly around the bushing and that the bottom stopper ("4" in fig. 1.39) is snug against the tube.

Motorized Access System
Installation of the motorized access assembly
Installation of the top anchor assembly

- 1- Remove the four bolt assemblies from the top anchor assembly and separate the top and bottom parts (see fig. 1.40).
- 2- Position the top part of the anchor so it sits on top of the tubes (shown as "A" and "B" in fig. 1.41 and fig. 1.42), to the left of the vertical tube close to the cylinder (shown as "C" in fig. 1.41) and toward the front of the motorized unit (fig. 1.42).

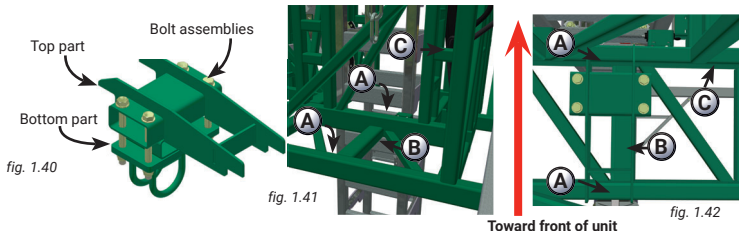

- 3- Align the bottom part of the anchor assembly under the top so it is snug against the tube running between them (shown as "B" in fig. 1.43 and fig. 1.45).
- 4- Secure the two parts together by tightening the four bolt assemblies with a torque of 120 lb-ft (163 N-m), making sure the anchor remains properly seated on the tubes.

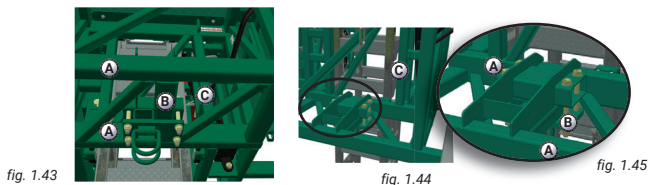
Opening of the front rollers

- 1- Using a 15/16" wrench, take away the rear bolt assemblies from each of the four front rollers (at the top and bottom) on the car assembly, as shown in fig. 1.46.
- 2- Flip open each of the front rollers, as shown in fig. 1.48.

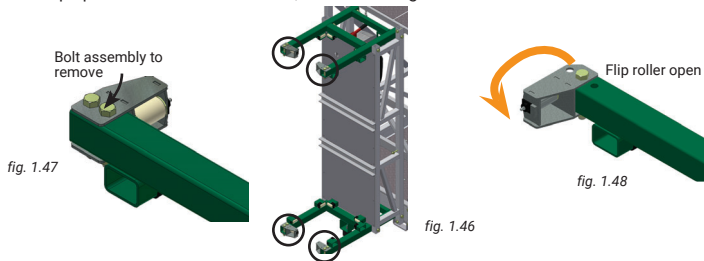

Motorized Access System

Installation of the motorized access assembly

Installation of the horizontal power cord support

- 1- Insert the horizontal power cord support through the car structure and secure it to the vertical tubes with bolt assemblies, as shown in fig. 1.49.
- 2- Using a U-bolt assembly, install the cable grip assembly on the support (fig. 1.50), at approximately 6' (1,8 m) from the traction hoist connector inside the car.

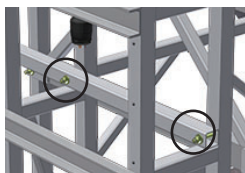

fig. 1.49

Location of bolt assemblies

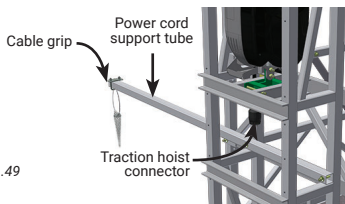

fig. 1.50

Installation of the ladder

- 1- Insert the ladder inside the car and through the roof hatch of the car.
- 2- Remove the bolt assemblies on the support at the bottom of the car (fig. 1.51).
- 3- Insert the bottom of the ladder between the tabs and secure in place by inserting the bolt assemblies through the tabs and through the holes at the bottom of the ladder (fig. 1.53 and fig. 1.54).

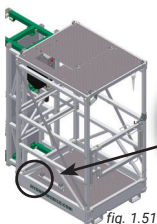

fig. 1.51

Bolt assemblies

fig. 1.52

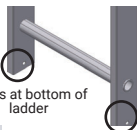

fig. 1.53

Holes at bottom of ladder

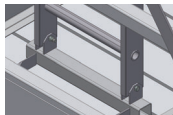

fig. 1.54

Installation of the access stairs

- 1- Align the access stairs (fig. 1.55) with the bottom of the motorized access car.
- 2- Secure in place with two bolt assemblies as shown in fig. 1.56 and fig. 1.58.

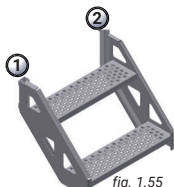

fig. 1.55

fig. 1.57

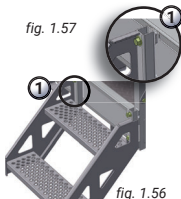

fig. 1.56

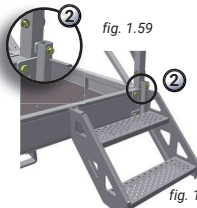

fig. 1.59

fig. 1.58

Motorized Access System

Installation of the motorized access assembly

Installation of the limit switch trigger plate

- 1- Make sure the two wire ropes are properly hooked to the top anchor assembly.
- 2- Remove the bolt assembly to separate the two halves of the trigger plate (fig. 1.60).
- 3- Carefully bring the car in position under the motorized unit, making sure to stop within 14" to 18" (35,6 cm to 45,7 cm) from the bottom tube of the motorized unit.
- 4- Position the two halves of the trigger plate around the two wire ropes (fig. 1.60), making sure that the primary and the secondary wire ropes are positioned properly (see fig. 1.60) and that the trigger arm cannot insert itself in a hole on the plate. Secure with the bolt assembly but do not tighten.

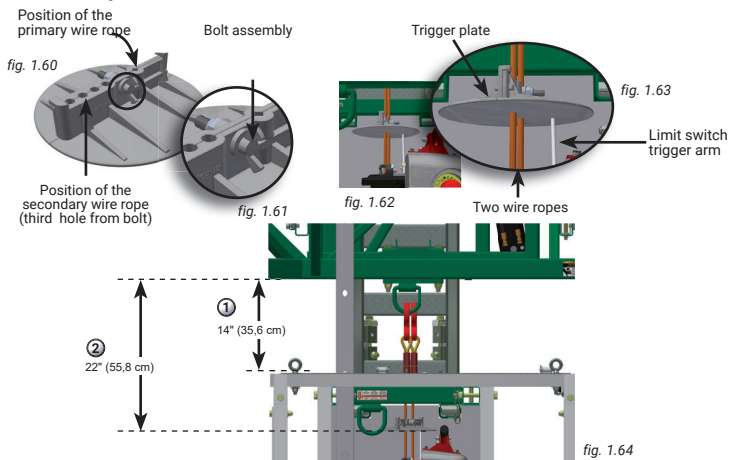

- 5- Measure the distance between the top of the car assembly and the bottom tube of the motorized unit frame ("1", in fig. 1.63). The top of the car must be at least 14" (35,6 cm) from the bottom tube of the motorized unit.
- 6- Adjust the height of the trigger plate so it is 22" (55,8 cm) under the bottom tube of the motorized unit ("2" in fig. 1.63).
- 7- Lower the car on the second full mast section, then bring it up again until the limit switch stops the car. Lift open the roof hatch door on the car and make sure that it is properly inserted into the notch in the locking latch (fig. 1.67), and that the top of the ladder has lifted the mechanical interlock of the unit access hatch (fig. 1.64).

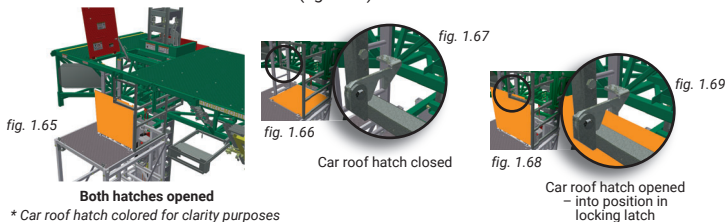

Motorized Access System

Using the motorized access system

Preparation of the motorized access system

- 1- Make sure an appropriately trained operator is available to operate the car.
- 2- Perform the daily inspection of the motorized access system.



- 1 Power indicator light
- 2 UP button
- 3 DOWN button
- 4 Emergency stop button

fig. 1.70

fig. 1.71

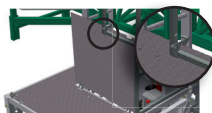

fig. 1.72

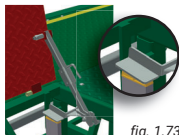

fig. 1.74

fig. 1.73

Raising the motorized access system

- 1- Close the car access gate. Make sure the roof hatch is closed.
- 2- Pull out the emergency stop button to power on the traction hoist (see fig. 1.70). If the power indicator light does not turn on, push in the emergency stop button and refer to the traction hoist owner's manual for troubleshooting.
- 3- Press and hold the UP button to raise the car.
- 4- When the limit switch trigger stops the car, release the UP button and push in the emergency stop button to power off the traction hoist.
- 5- Lift open the roof hatch door on the car and make sure that it is properly inserted into the notch in the locking latch. Make sure that the ladder has pushed up the mechanical interlock (fig. 1.72) to allow opening the unit access hatch (red). It is important to call out a warning to other workers on the platform before opening the unit access hatch.

Lowering the motorized access system

- 1- When the last person has descended into the car, close the unit access hatch properly.
- 2- Pull out the emergency stop button to power on the traction hoist (see fig. 1.70). If the power indicator light does not turn on, push in the emergency stop button and refer to the traction hoist owner's manual for troubleshooting.
- 3- Press and hold the DOWN button to lower the car.
- 4- Carefully monitor the descent as the car moves down from the motorized unit to make sure the roof hatch closes properly.
- 5- Carefully monitor the descent as the car approaches base level to make sure there are no obstacles under it and that the access stairs are seated properly.
- 6- Once at base level, release the DOWN button and push in the emergency stop button to power off the traction hoist.

Using the emergency descent system

In the event of a power outage or any incident, it is recommended to use the emergency descent system to bring the workers and the motorized access car safely to base level.

Follow the instructions included in the traction hoist owner's manual. Lower the red lever on top of the traction hoist control box when instructions require to raise the emergency descent lever.



fig. 1.75



fig. 1.77



fig. 1.76